

BERLINE / SEDAN / LIMOUSINE K70

80176

Français

Afin de disposer à peu de frais d'un nouveau modèle qui devait se substituer à la 411, Volkswagen qui venait de racheter Audi en 1965 et NSU en 1969, emprunta à cette dernière entreprise un de ses modèles qui devait sortir en 1970 au lieu de partir d'une feuille blanche pour la création de sa nouvelle berline. Elle est la première traction avant de Volkswagen. En 1973, Volkswagen Passat lui succédera.

Moteur	4 cylindres en ligne
Puissance D.I.N.	90 cv à 5200 t/mn
Boîte de vitesses manuelle à 4 rapports	
Cylindrée	1595 cm ³
Vitesse maxi.	158 km/h
Poids en ordre de marche	1100 kg
Longueur	4,470 m
Largeur	1,685 m
Hauteur	1,465 m

English

In order to have a new model to replace the 411 at low cost, Volkswagen, which had just bought Audi in 1965 and NSU in 1969, borrowed one of its models from the latter company to be released in 1970 instead of starting from scratch with the creation of its new saloon. It was Volkswagen's first front-wheel drive car. In 1973, the Volkswagen Passat succeeded it.

Engine	4 cylinders in line
D.I.N. power	90 hp at 5200 rpm
4-speed manual gearbox	
Displacement	1595 cm ³
Top speed	158 km/h
Weight in running order	1100 kg
Length	4,470 m
Width	1,685 m
Height	1,465 m

Deutsch

Um kostengünstig ein neues Modell als Ersatz für den 411 zu bekommen, lieh sich Volkswagen, die 1965 gerade Audi und 1969 NSU gekauft hatten, von letzterem Unternehmen ein Modell. Das Modell kam schon 1970 auf den Markt, anstatt mit der Entwicklung einer neuen Limousine ganz von vorne anzufangen. Es war das erste Auto von Volkswagen mit Frontantrieb. 1973 folgte ihm der Volkswagen Passat.

Motor	4 Zylinder in Reihe
Leistung	90 PS bei 5200 U/min
4-Gang-Schaltgetriebe	
Hubraum	1595 cm ³
Höchstgeschwindigkeit	158 km/h
Gesamtgewicht	1100 kg
Länge	4,470 m
Breite	1,685 m
Höhe	1,465 m

Español

Para disponer de un nuevo modelo de bajo coste que sustituiría al 411, Volkswagen, que acababa de comprar Audi en 1965 y NSU en 1969, tomó prestado de esta última compañía uno de sus modelos que sería lanzado en 1970, en lugar de empezar de cero, para la creación de su nueva berlina. Este será el primer modelo con tracción delantera de Volkswagen. En 1973, le seguiría el Volkswagen Passat.

Motor	4 cilindros en línea
Potencia D.I.N.	90 CV a 5.200 rpm
Caja de cambios manual de 4 velocidades	
Cilindrada	1595 cm ³
Velocidad máxima	158 km/h
Peso en orden de marcha	1100 kg
Longitud	4,470 m
Anchura	1,685 m
Altura	1,465 m

Italiano

Al fine di disporre di un nuovo modello a un costo contenuto che sostituisce la 411, Volkswagen, che aveva appena acquistato Audi nel 1965 e NSU nel 1969, prese in prestito da quest'ultima azienda uno dei suoi modelli, che sarebbe uscito nel 1970, invece di partire da zero, per creare la sua nuova berlina. Si trattava della prima auto a trazione anteriore della Volkswagen. Nel 1973, viene sostituita dalla Volkswagen Passat.

Motore	4 cilindri in linea
Potenza D.I.N.	90 CV a 5200 rpm
Cambio manuale a 4 velocità	
Cilindrata	1595 cm ³
Velocità massima	158 km/h
Peso in ordine di marcia	1100 kg
Lunghezza	4,470 m
Larghezza	1,685 m
Altezza	1,465 m

Nederlands

Volkswagen kocht Audi in 1965 en NSU in 1969, en leende van deze laatste een van zijn modellen die in 1970 zou worden uitgebracht om tegen lage kosten een nieuw model ter vervanging van de 411 aan te bieden en niet van nul zijn nieuwe sedan te moeten ontwerpen. Het is de eerste voorwielaandrijving van Volkswagen. In 1973 volgde Volkswagen Passat hem op.

Motor	4 cilinders in lijn
Potenza D.I.N.	90 PS bij 5200 tpm
4-speed handgeschakelde versnellingsbak	
Cilinderinhoud	1595 cm ³
Topsnelheid	158 km/u
Gewicht in rijklare toestand	1100 kg
Lengte	4,470 m
Breedte	1,685 m
Hoogte	1,465 m

11 Argent Silver Silber

16 Or Gold

33 Noir mat Matt black Matt-Schwarz

64 Gris clair mat Matt light grey Matt-Hellgrau

87 Gris acier mat Matt steel grey Matt-Stahlgrau

321 Rouge transparent Clear red Durchsichtiges Rot

322 Orange transparent Clear orange Durchsichtiges Orange

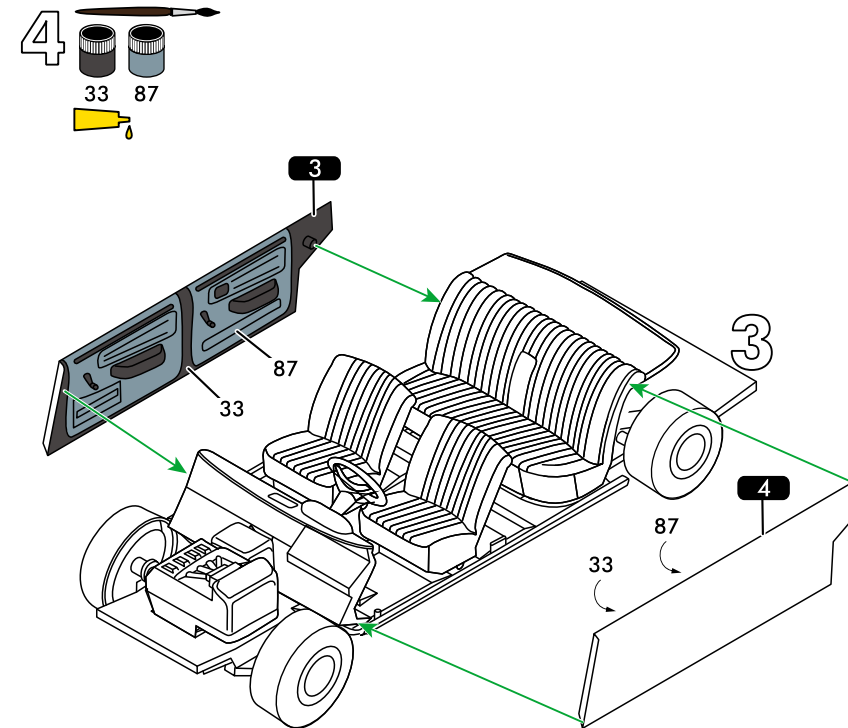
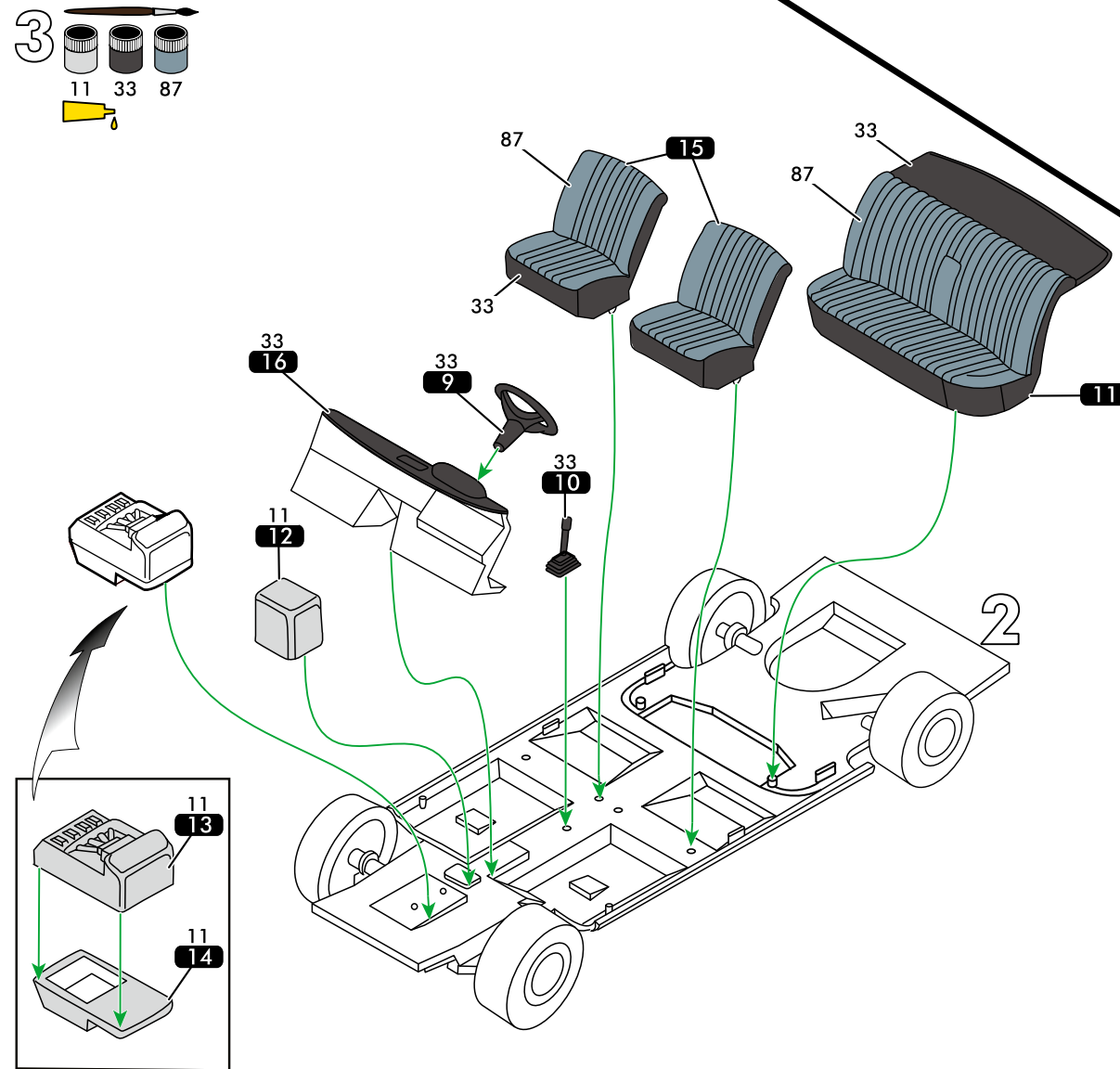
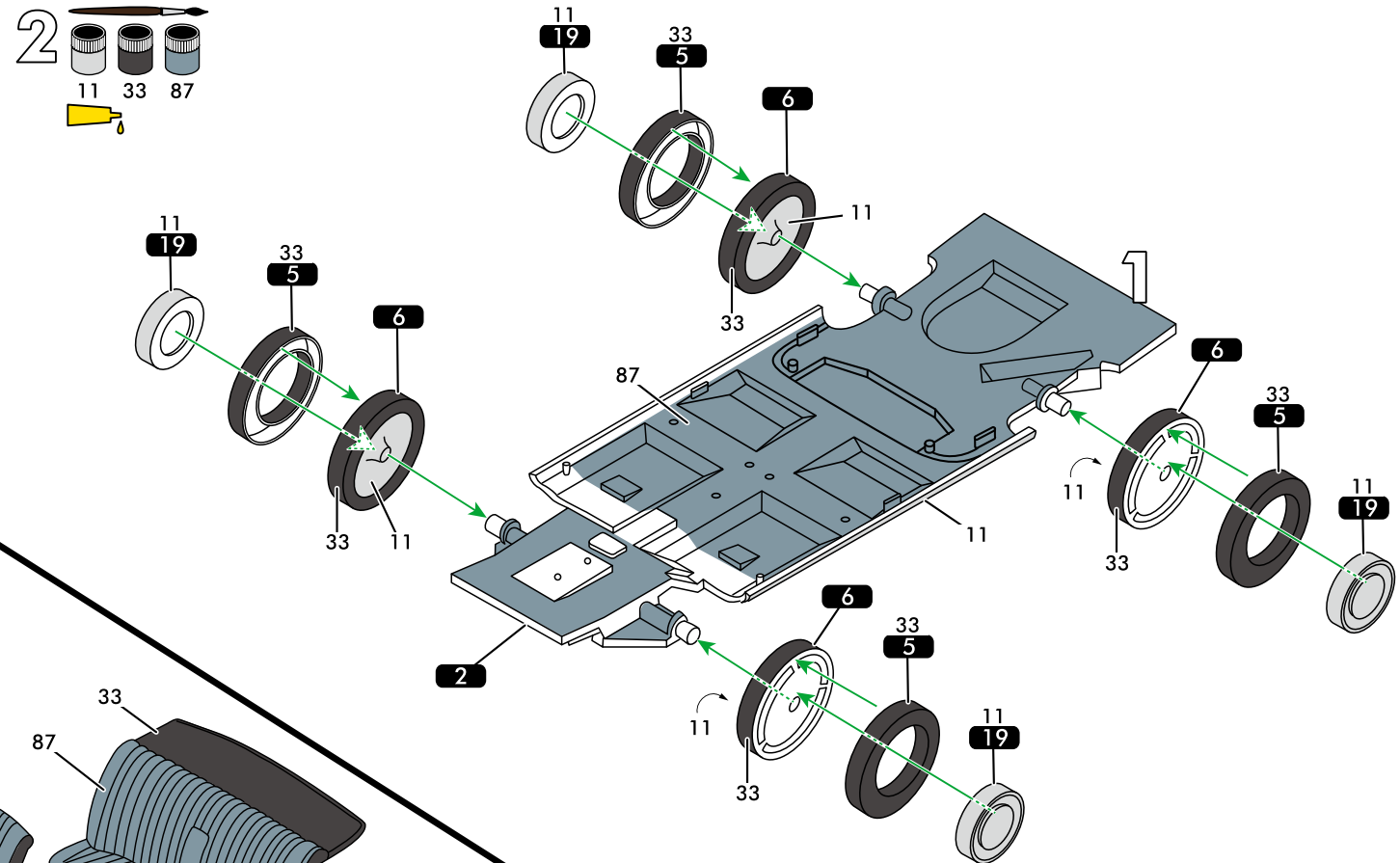
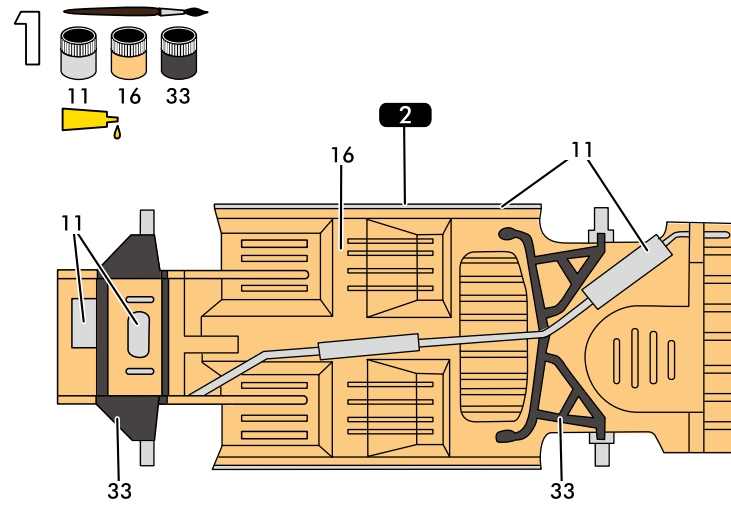

80176-176

Instagram.com/heller.fr
Facebook.com/heller.fr

Heller Hobby GmbH
Erlenbacher Str. 3 • 42477 Radevormwald • GERMANY
+49 (0) 2195-92773-0 info@heller.fr

Endverbraucher Service
Bitte besuchen Sie uns auf www.heller.fr
für alle Ersatzteilanfragen.

Customer Service
For after-sales service requests, please contact
us through our website www.heller.fr.

Service consommateurs
Pour toute demande de SAV, connectez-vous
sur notre site www.heller.fr.

Heller

