

CITROËN DS 19

80162

Français

Les premières esquisses du Projet VGD (Voiture à Grande Diffusion) remontent à 1945. La DS 19 CITROËN sera présentée au 42ème Salon de l'Auto de Paris le 6 octobre 1955. Des matériaux nouveaux: matière plastique, alliages légers, et des techniques de pointe: suspension hydropneumatique pour 4 roues indépendantes, sont mises au service d'une esthétique révolutionnaire, qui partagera la France en deux: les «pour» et les «contre».

English

The first draft of the GMV (General Market Vehicle) project dates back to 1945. The CITROËN DS 19 unveiled at the 42nd Automobiles Trade Fair in Paris on October 6th, 1955. New materials: plastics, light alloys, and leading edge technology: 4-wheel independent hydro pneumatic suspensions, combined with a revolutionary line were to divide France in two: the «fors» and the «against».

Deutsch

Das Projekt zur Massenproduktion stammt aus dem Jahre 1945. Der CITROËN DS 19 wurde auf der 42. Automobilmesse in Paris am 6. Oktober 1955 vorgestellt. Neue Materialien: Plastik und Leichtmetalllegierung, sowie neue Technologien: hydropneumatische Aufhängung für 4 unabhängige Räder, wurden mit einem Design vereinigt, das Frankreich in zwei Lager spaltete: das eine „pro“, das andere „contra“.

Español

Los primeros esbozos del proyecto VGD (Vehículo de Gran Difusión) se remontan a 1945. El DS 19 CITROËN será presentado en el 42º Salón del Automóvil de París el 6 de octubre de 1955. Nuevos materiales: plástico, aleaciones ligeras, y técnicas punteras: suspensión hidroneumática para 4 ruedas independientes, al servicio de una estética revolucionaria, que dividirá Francia en dos: los "defensores" y los "detractores".

Italiano

I primi schizzi del progetto VGD (Auto a Grande Diffusione) risalgono al 1945. La DS 19 CITROËN sarà presentata al 42° Salone dell'Automobile di Parigi il 6 ottobre 1955. Nuovi materiali: plastica, leghe leggere e tecniche di fulmini. punto: le sospensioni idropneumatiche per 4 ruote indipendenti, sono messe al servizio di un'estetica rivoluzionaria, che condividerà la Francia in due: «per» e «contro».

Nederlands

De eerste schetsen van het VGD-project (Grote Diffusie Auto) dateren uit 1945. De DS 19 CITROËN wordt gepresenteerd op de 42e Autosalon van Parijs op 6 oktober 1955. Nieuwe materialen: kunststoffen, lichtmetalen en bliksemtechnieken. punt: hydropneumatische vering voor 4 onafhankelijke wielen, wordt ten dienste gesteld van een revolutionaire esthetiek, die Frankrijk in twee delen: «voor» en «tegen».



11
Argent
Silver
Silber



33
Noir mat
Matt black
Mattschwarz



41
Ivoire brillant
Gloss ivory
Glänzend-Elfenbein



85
Noir de charbon satiné
Satin coal black
Seidenmatt-Kohlenschwarz



186
Brun
Brown
Braun



321
Rouge transparent
Clear red
Durchsichtiges Rot

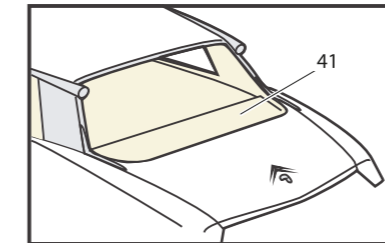
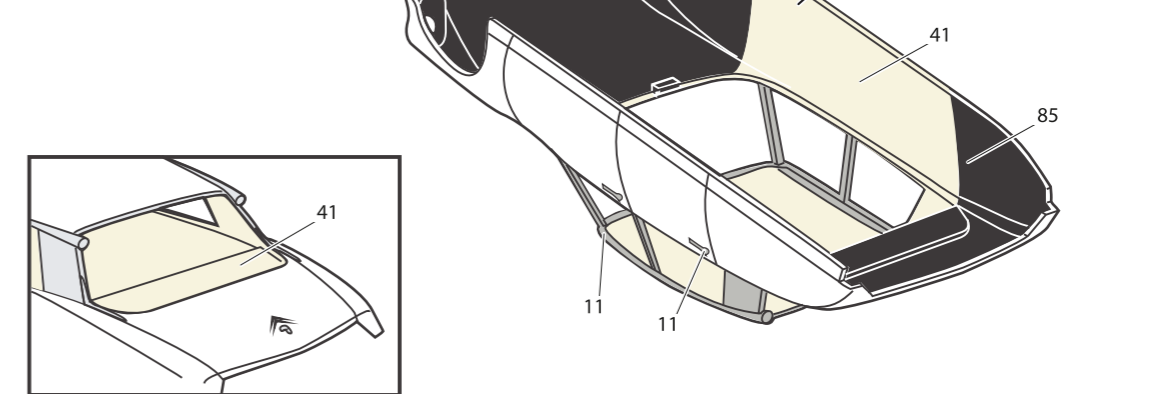
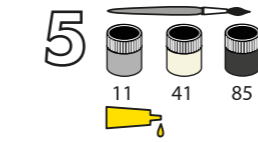
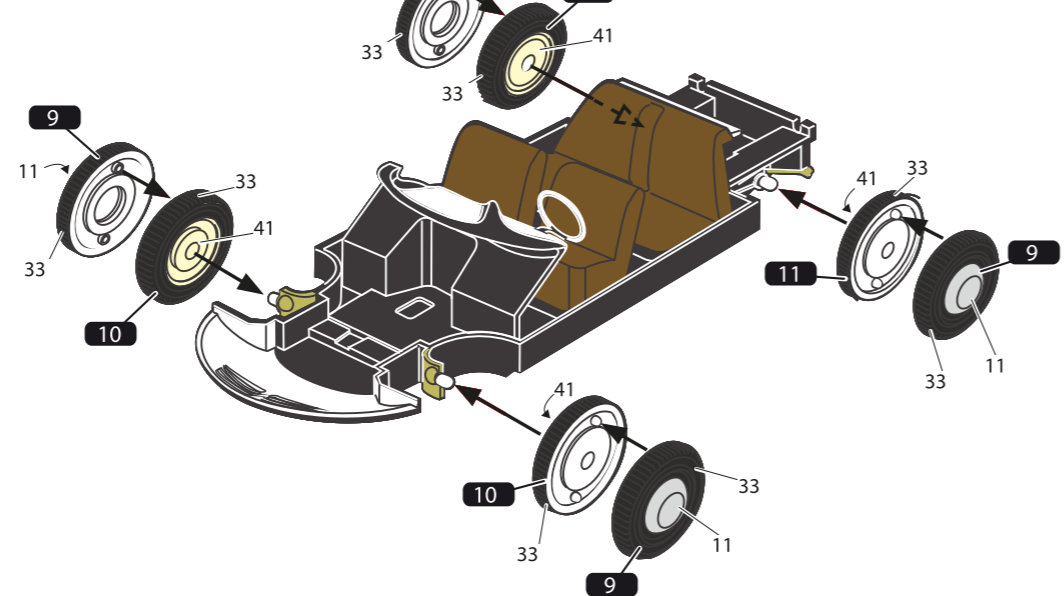
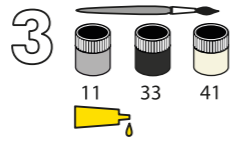
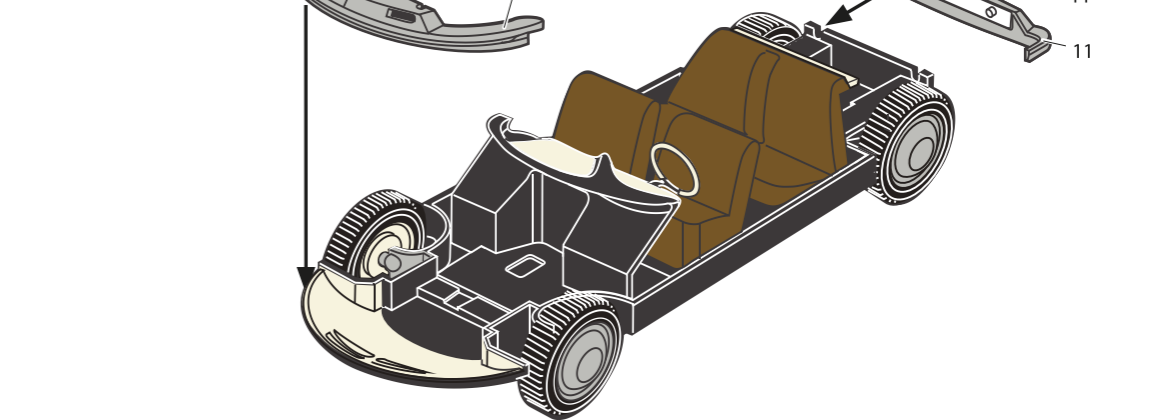
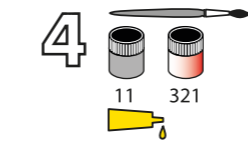
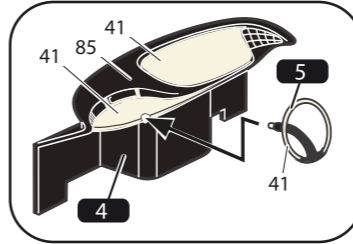
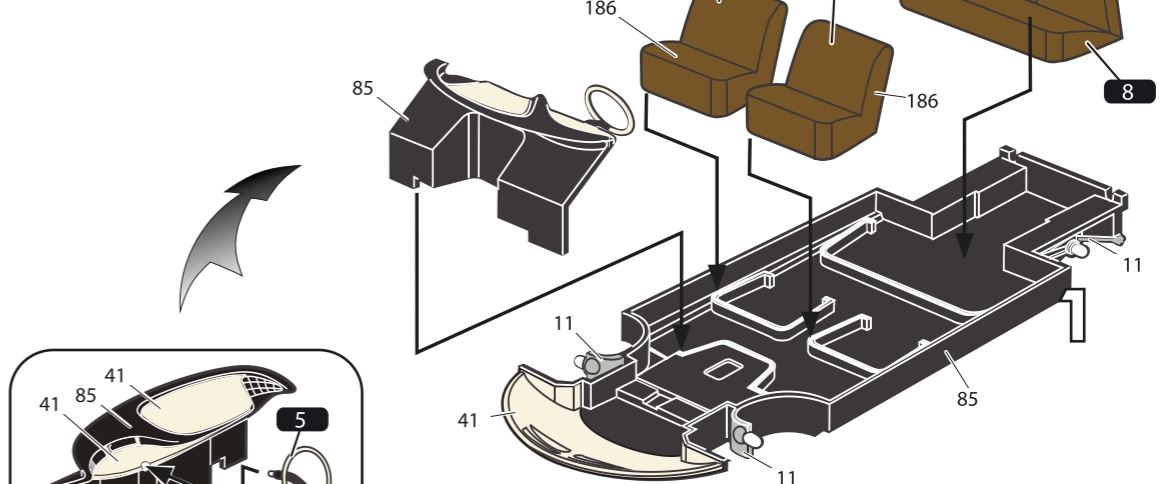
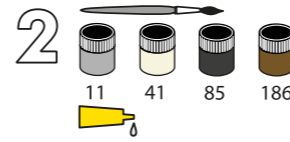
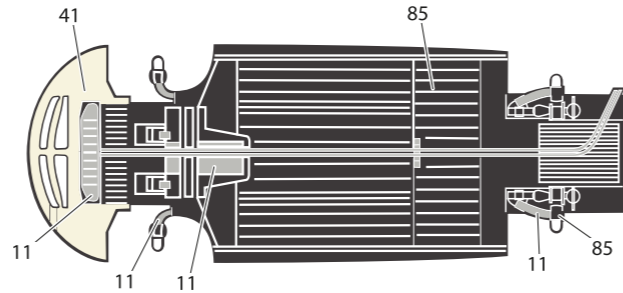
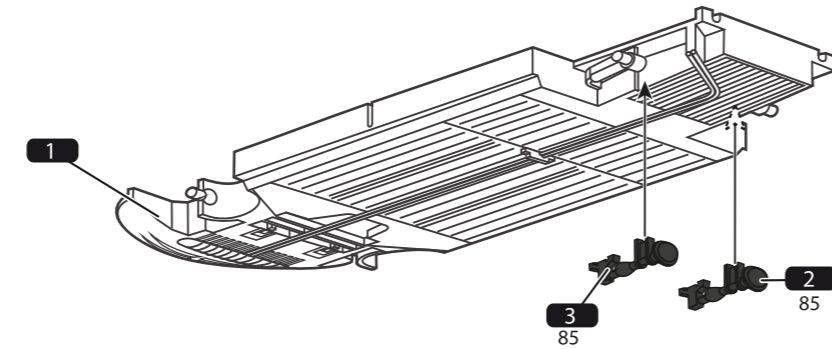
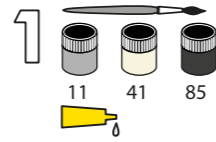

80162-176

6
11 41 85

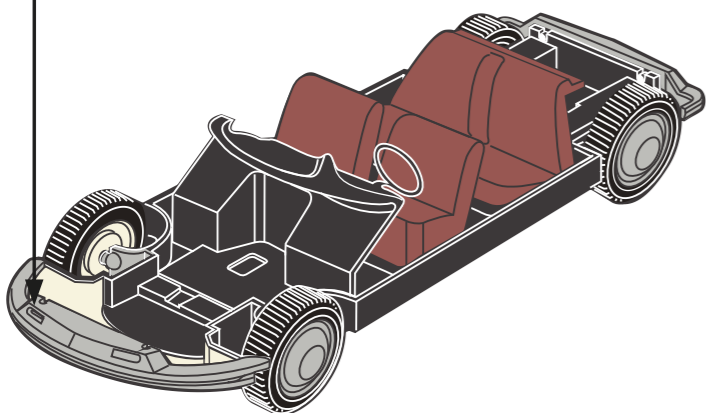
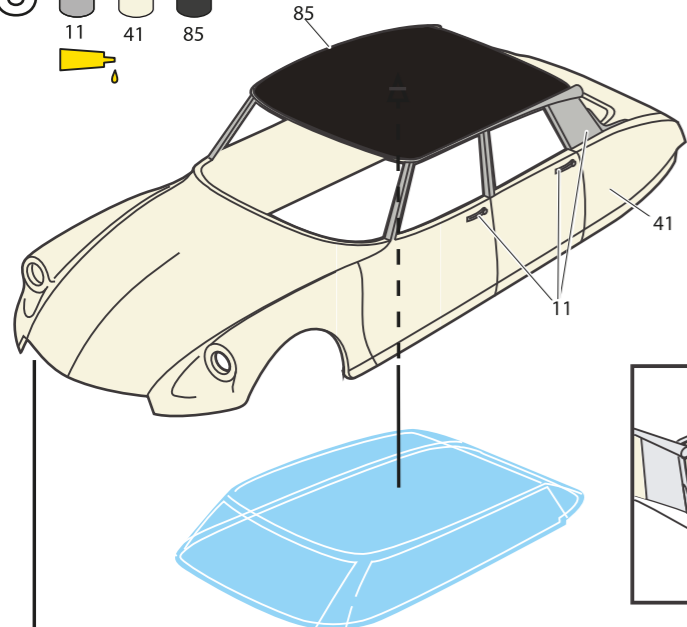

7
11

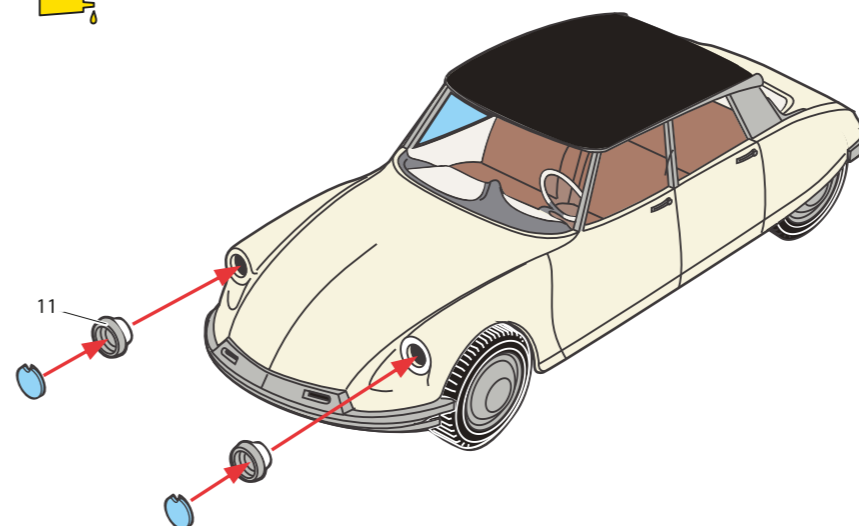

8

