

Heller

YAMAHA TY 125

80902



DÉCOUVREZ LE MONDE DES PEINTURES ACRYLIQUES HELLER !

DISCOVER THE WORLD OF HELLER ACRYLIC PAINTS!
ENTDECKEN SIE DIE WELT DER HELLER ACRYL-FARBEN!



- FACILE À UTILISER
- DILUABLE À L'EAU
- POTS DE PEINTURE STABLES
- BOUCHON À VIS SÉCURISÉ

- EASY TO USE
- DILUTABLE WITH WATER
- STABLE PAINT CANS
- SECURE SCREW CAP

- EINFACHE ANWENDUNG
- MIT WASSER VERDÜNNBAR
- STANDFESTE FARBDOSEN
- SICHERER SCHRAUBVERSCHLUSS

Français

Moto de trial aussi bien équipée que finie, la 125 TY YAMAHA a été dessinée dans ses grandes lignes par l'ancien champion de trial Mick ANDREWS. Son cadre géométrique et l'emploi d'alliages spéciaux dans la réalisation de certaines pièces la rendaient extrêmement maniable. Son moteur très souple équipé d'une boîte six vitesses bien étagées et une suspension très correcte lui permettaient de rouler en ville. HELLER vous propose le type 1K6, apparu en 1976, au silencieux plus volumineux que celui du modèle initial type 541, et aux carters moteur noir satiné au lieu d'aluminium poli.

Année de fabrication	1974
Quantité produite	53.000
Puissance	10 CV
Vitesse maximale	100 km/h
Longueur totale	1,97 m

Deutsch

Die YAMAHA TY 125 wurde vom ehemaligen Trial-Champion Mick ANDREWS in groben Zügen entworfen. Der geometrische Rahmen und die Verwendung spezieller Legierungen bei der Herstellung bestimmter Teile, machten das Motorrad äußerst handlich. Der Motor, der mit einem gut abgestuften Sechsganggetriebe und einer guten Motorhalterung ausgestattet war, ermöglichte es auch in der Stadt zu fahren. HELLER bietet Ihnen den 1976 erschienenen Typ 1K6 mit einem größeren Schalldämpfer und satinschwarzen Motorgehäusen, anstelle von poliertem Aluminium, des ursprünglichen Modells vom Typ 541, an.

Baujahr	1974
Gebaute Menge	53.000
Leistung	10 PS
Max. Geschwindigkeit	100 km/h
Gesamtlänge	1,97 m

Italiano

La 125 TY YAMAHA è stata progettata dall'ex campione di trial Mick ANDREWS a grandi linee. Il telaio geometrico e l'uso di leghe speciali nella fabbricazione di alcuni pezzi la rendono estremamente maneggevole. Il motore molto flessibile, dotato di un cambio a sei marce facilmente scalabili e di ottime sospensioni, permette di guidare in città. HELLER propone il Tipo 1K6 del 1976 con un silenziatore più grande rispetto al modello originale Tipo 541, con carter del motore nero satinato al posto dell'alluminio lucido.

Anno di costruzione	1974
Grande quantità	53.000
Potenza	10 PS
Velocità massima	100 km/h
lunghezza totale	1,97 m

English

Trial bike as well equipped as it is finished, the 125 TY YAMAHA was designed in broad outline by former trial champion Mick ANDREWS. Its geometrical frame and the use of special alloys in the production of certain parts made it extremely handy. Its very flexible engine equipped with a well-staged six-speed gearbox and very good suspension allowed it to drive in the city. HELLER offers you the type 1K6, which appeared in 1976, with a larger silencer than that of the initial model type 541, and satin black engine casings instead of polished aluminum.

Year of construction	1974
Built quantity	53000
Power	10 PS
Max. speed	100 km/h
Total length	1.97 m

Español

La YAMAHA TY 125 fue diseñada en líneas generales por el antiguo campeón de trial Mick ANDREWS. Su marco geométrico y el uso de aleaciones especiales en la fabricación de ciertas piezas la hacían extremadamente manejable. Su motor muy flexible, equipado con una caja de cambios de seis velocidades bien escalonada y una muy buena suspensión, le permitía ser conducida en ciudad. HELLER ofrece el tipo 1K6 de 1976 con un silenciador más grande que el modelo original tipo 541 y cárteres de motor en negro satinado en lugar de aluminio pulido.

Año de construcción	1974
Cantidad construida	53.000
Potencia	10 PS
Velocidad máxima	100 km/h
Longitud total	1,97 m

Nederlands

De 125 TY YAMAHA is als trial bike net zo goed uitgerust als afgewerkt en werd in grote lijnen ontworpen door voormalig trialkampioen Mick ANDREWS. Het geometrische frame en het gebruik van speciale legeringen bij de productie van bepaalde onderdelen maakten hem uitermate handig. Zijn zeer flexibele motor is uitgerust met een goed gefaseerde zesversnellingsbak en een zeer goede vering maakt het rijden in de stad mogelijk. HELLER biedt u het type 1K6 dat verscheen in 1976, met een grotere geluiddemper dan die van het oorspronkelijke model type 541 en met satijnzwarte motorbehuizingen in plaats van gepolijst aluminium.

Bouwjaar	1974
Bedrag gebouwd	53.000
Vermogen	10 PS
Maxi snelheid	100 km/h
Totale lengte	1,97 m

1/8

YAMAHA TY 125

80902



11
Argent métallique
Silver Metallic
Silber metallisch



19
Rouge vif brillant
Bright Red Gloss
Hellrot glänzend



22
Blanc brillant
White Gloss
Weiß glänzend



33
Noir mat
Black Matt
Schwarz matt



34
Blanc mat
White Matt
Weiß matt



35
Vernis brillant
Clear Poly Gloss
Klarlack glänzend



56
Aluminium métallique
Aluminium Metallic
Aluminium metallisch



69
Jaune brillant
Yellow Gloss
Gelb glänzend



321
Rouge transparent
Red Transparent
Rot transparent

2

Numéro de phase
Step number
Schrittnummer
Número de fase

56

Référence de couleur
Colour reference no
Farbangabe
Referencia de color

37

Numéro de pièce
Part number
Teilenummer
Número de pieza

6

Numéro de decal
Decal number
Abziehbildnummer
Número de calcomanía

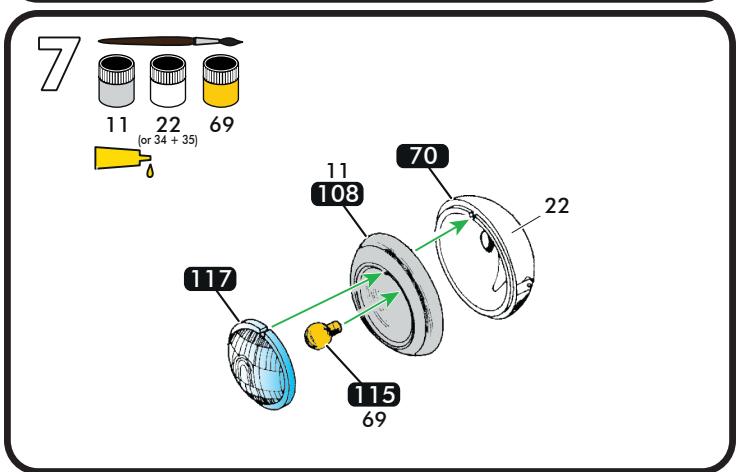
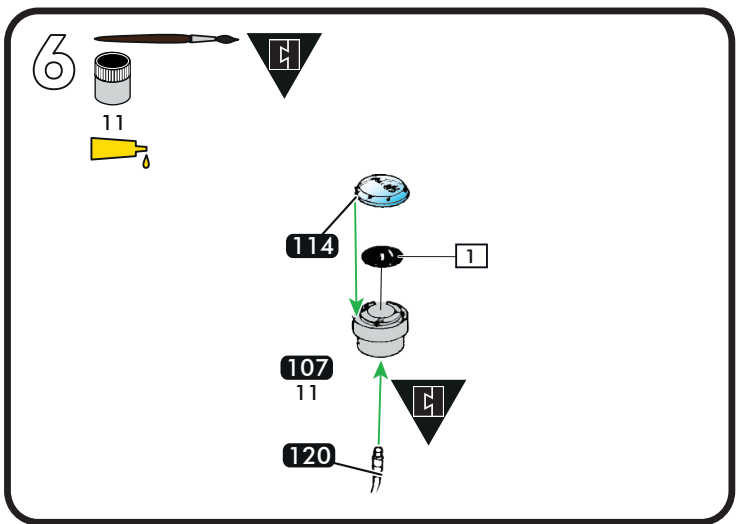
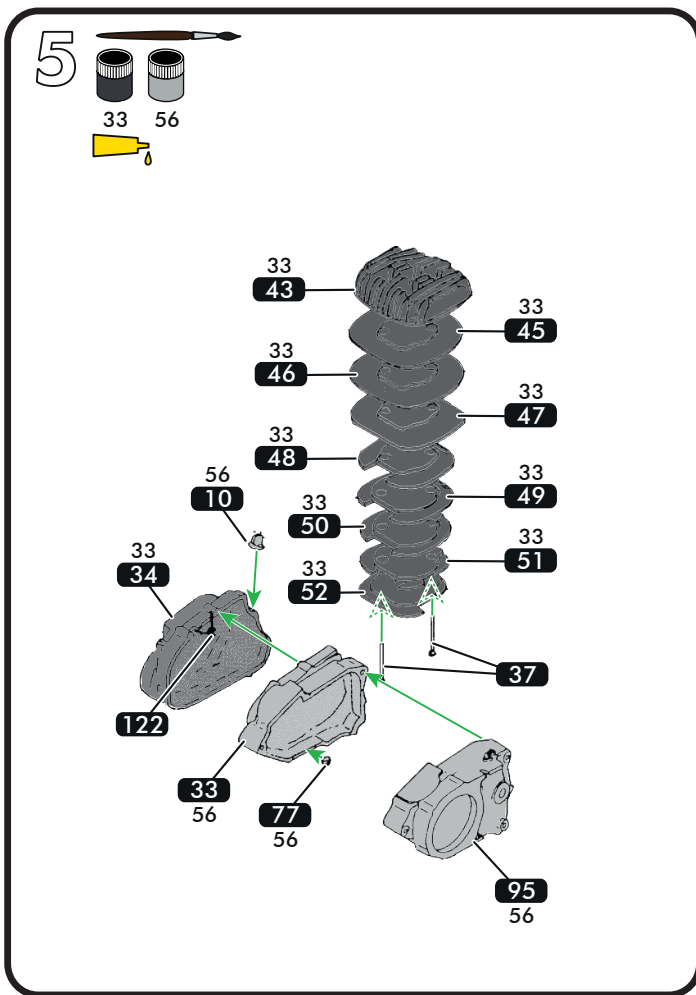
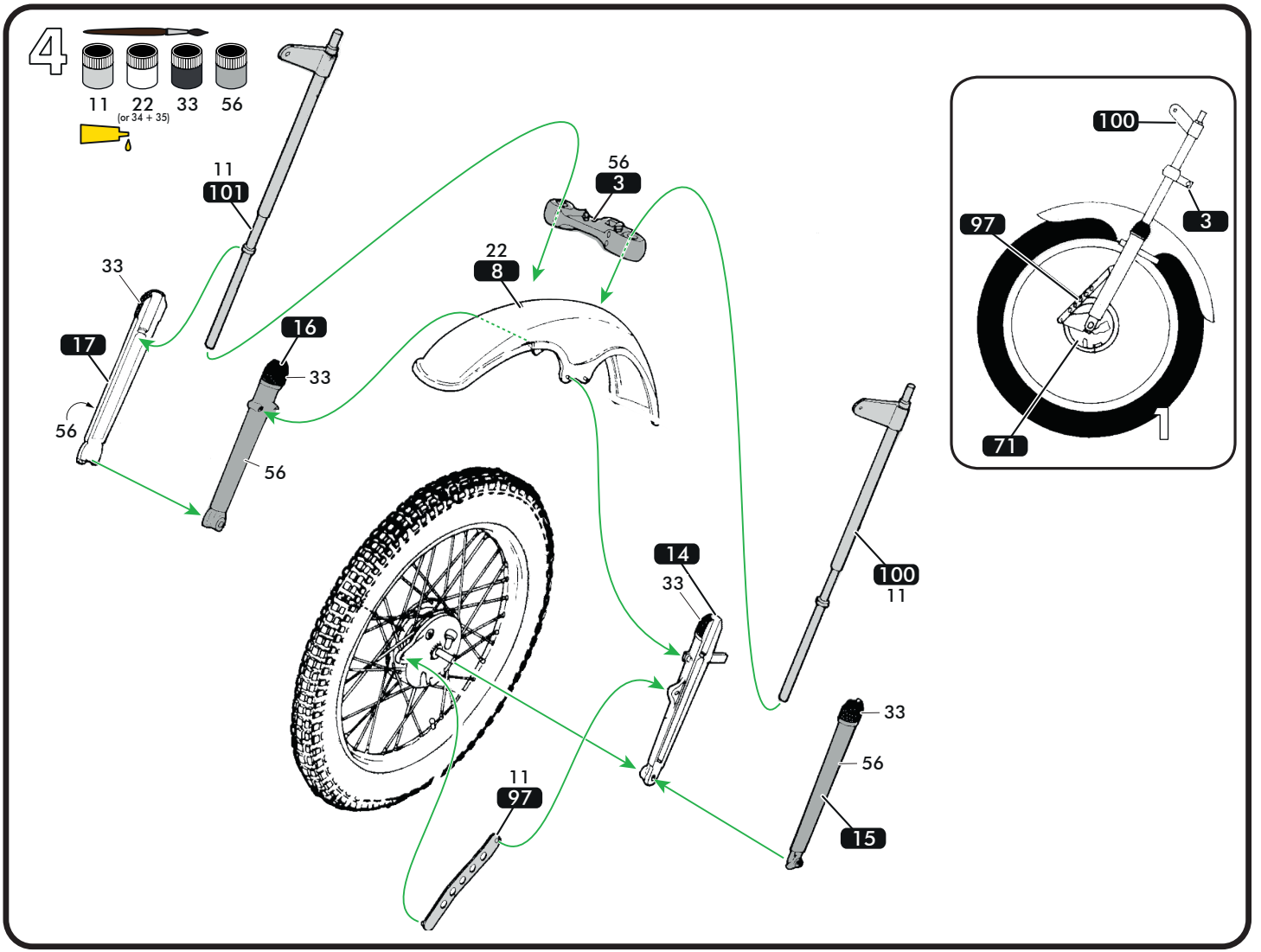

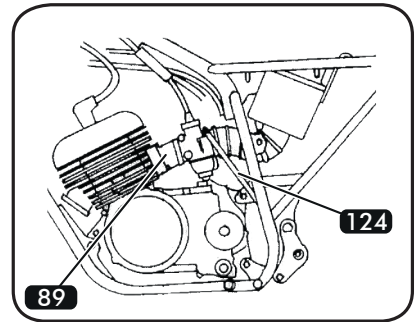
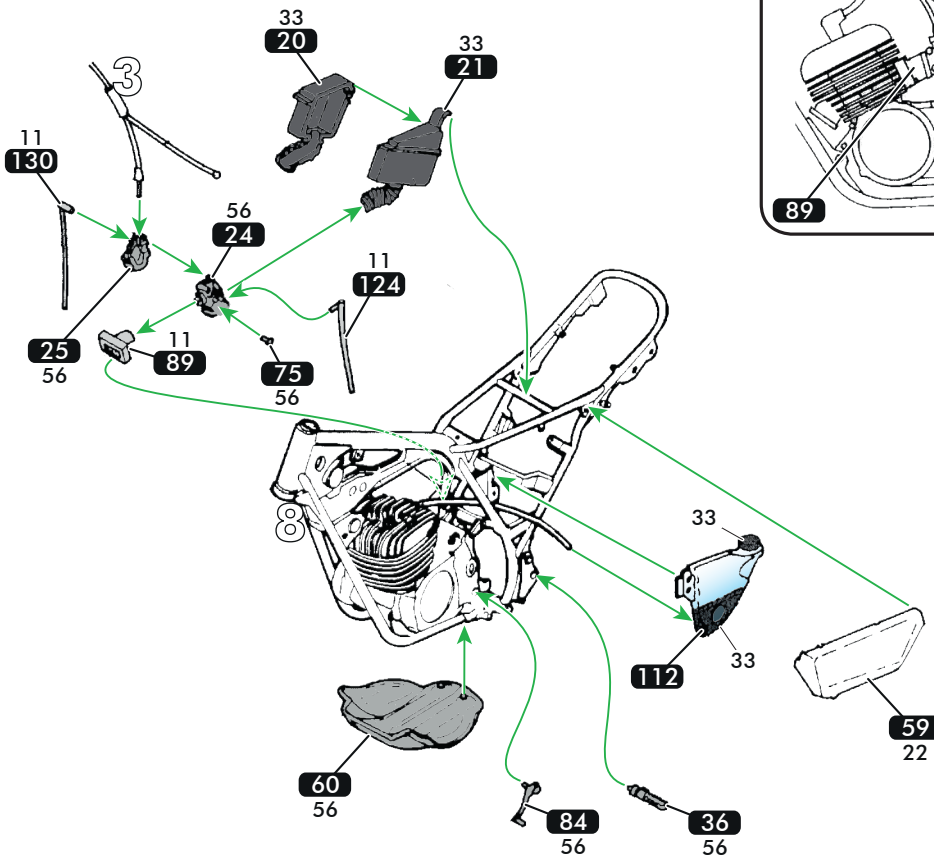
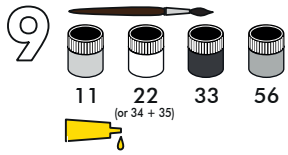
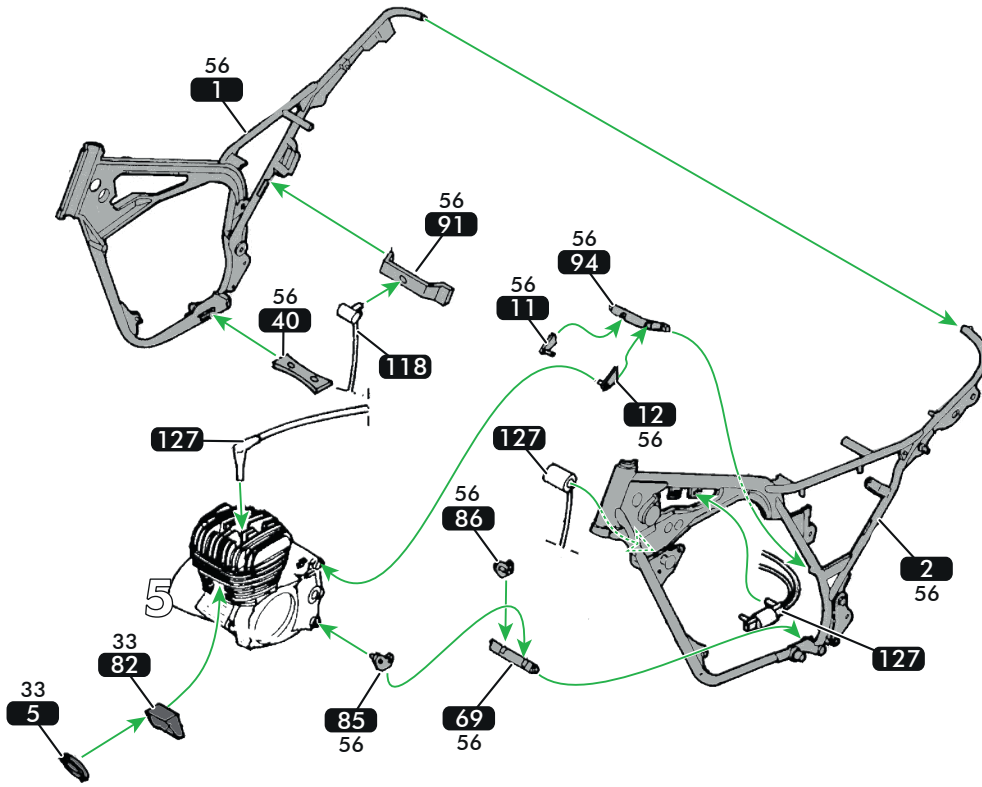
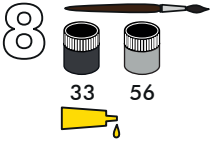

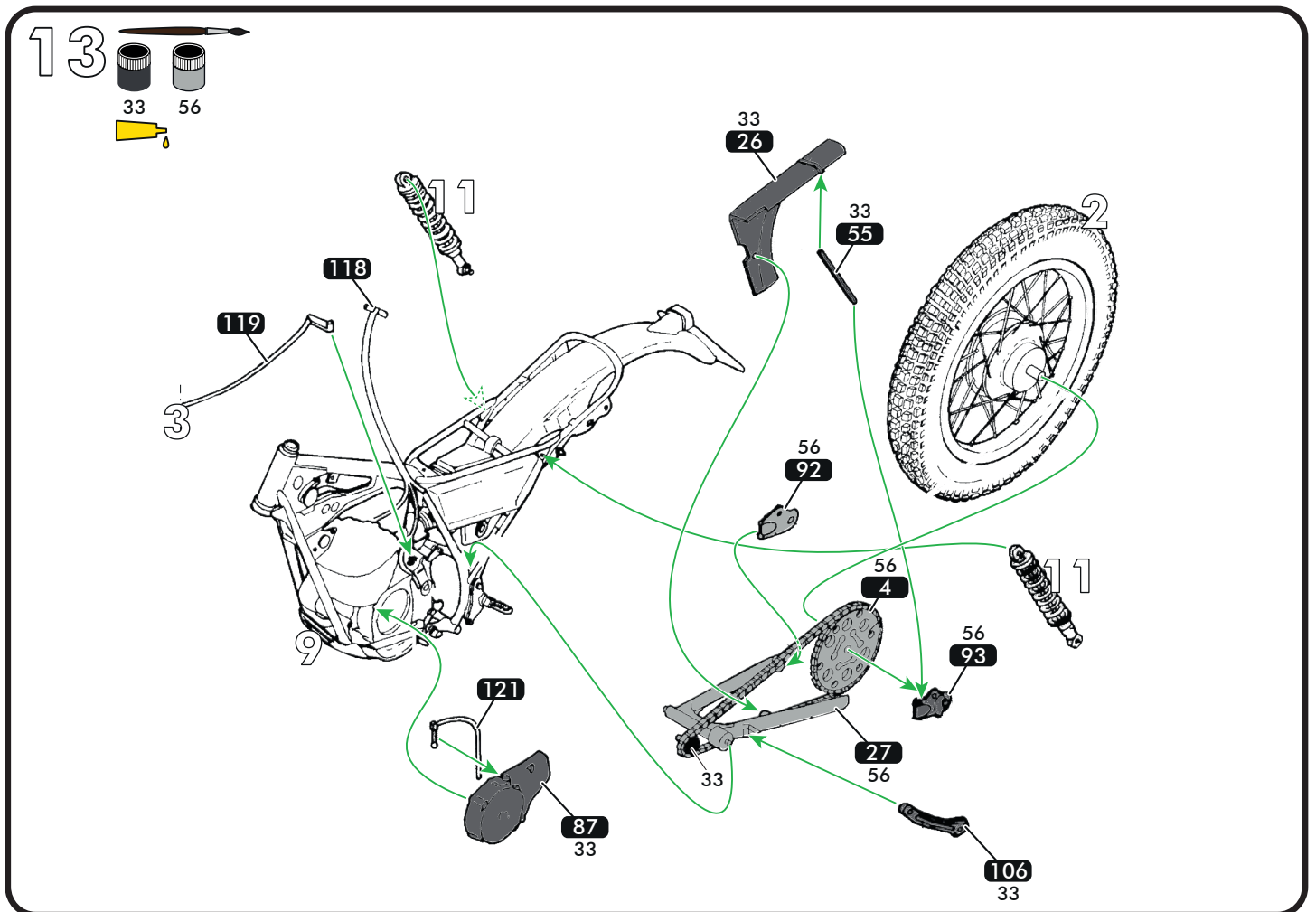
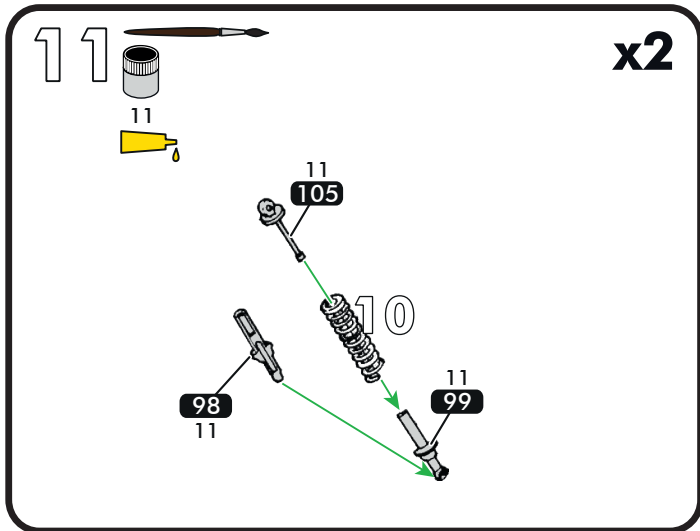
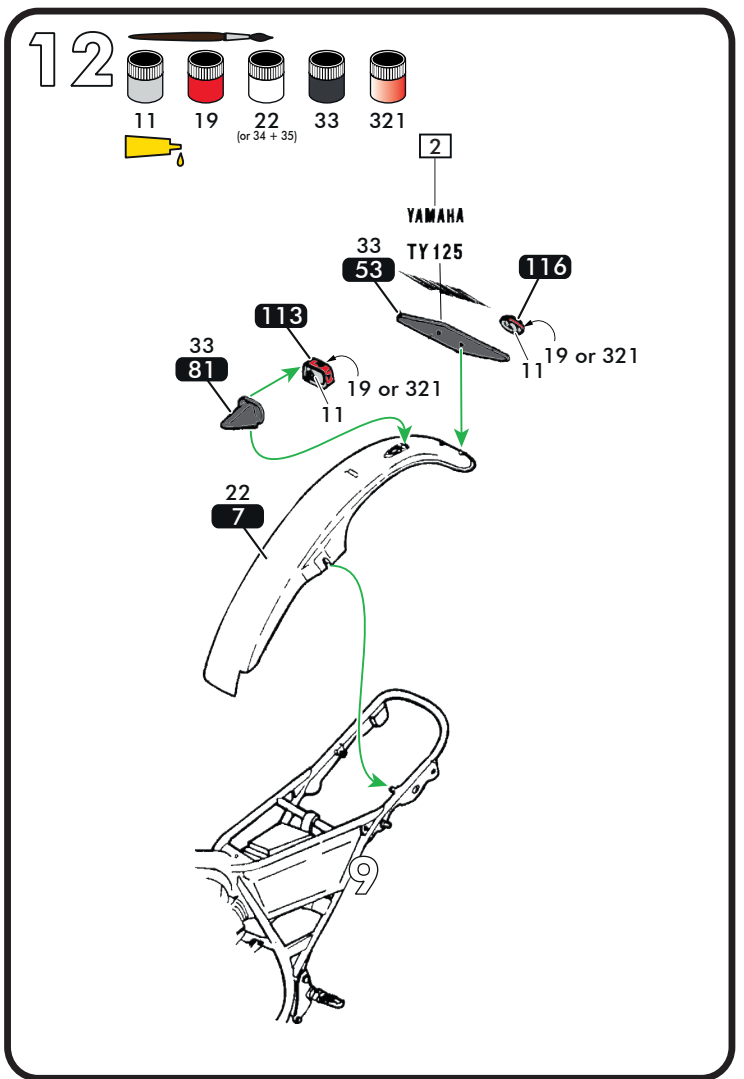
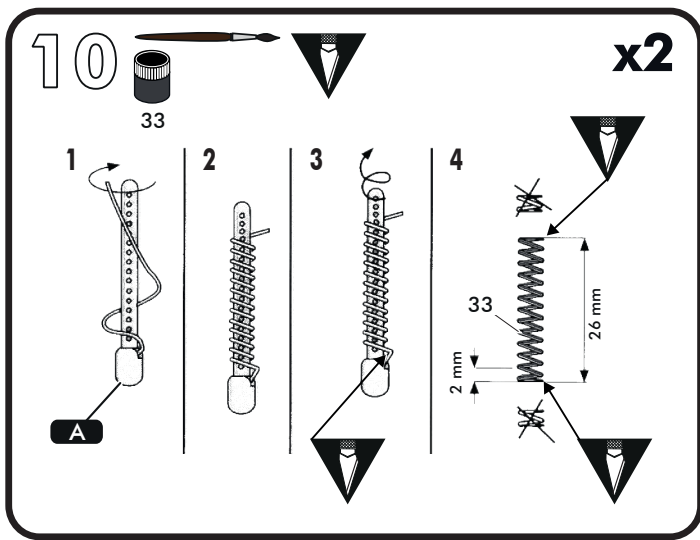

14

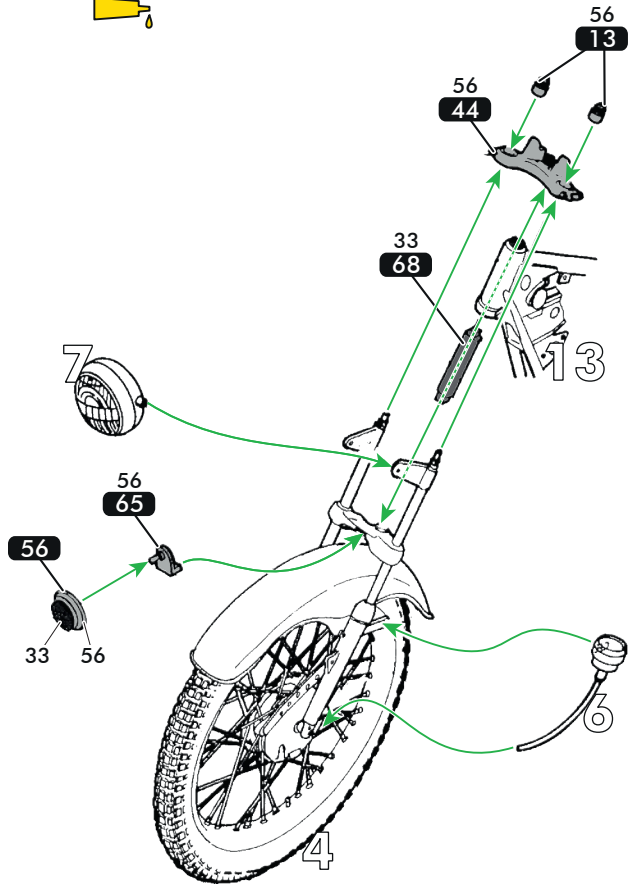
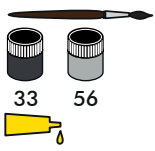

15

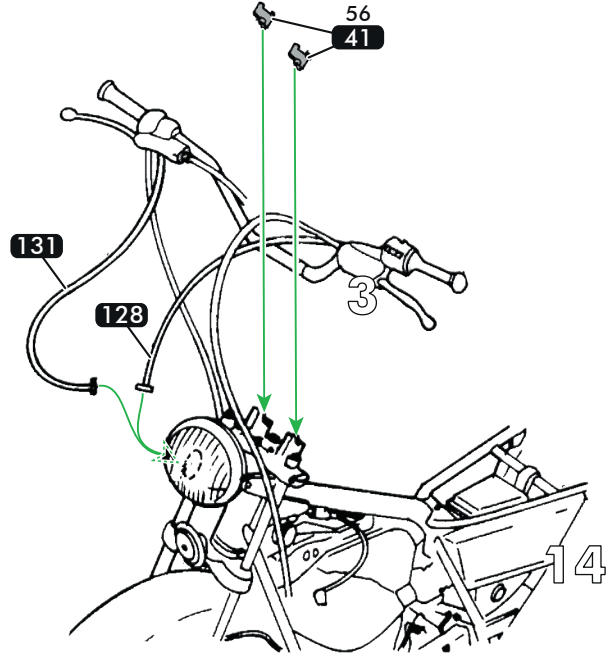
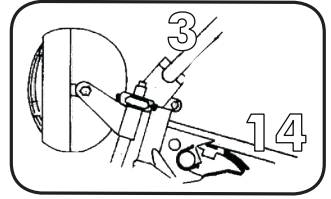
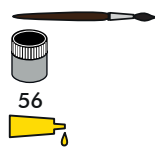

16

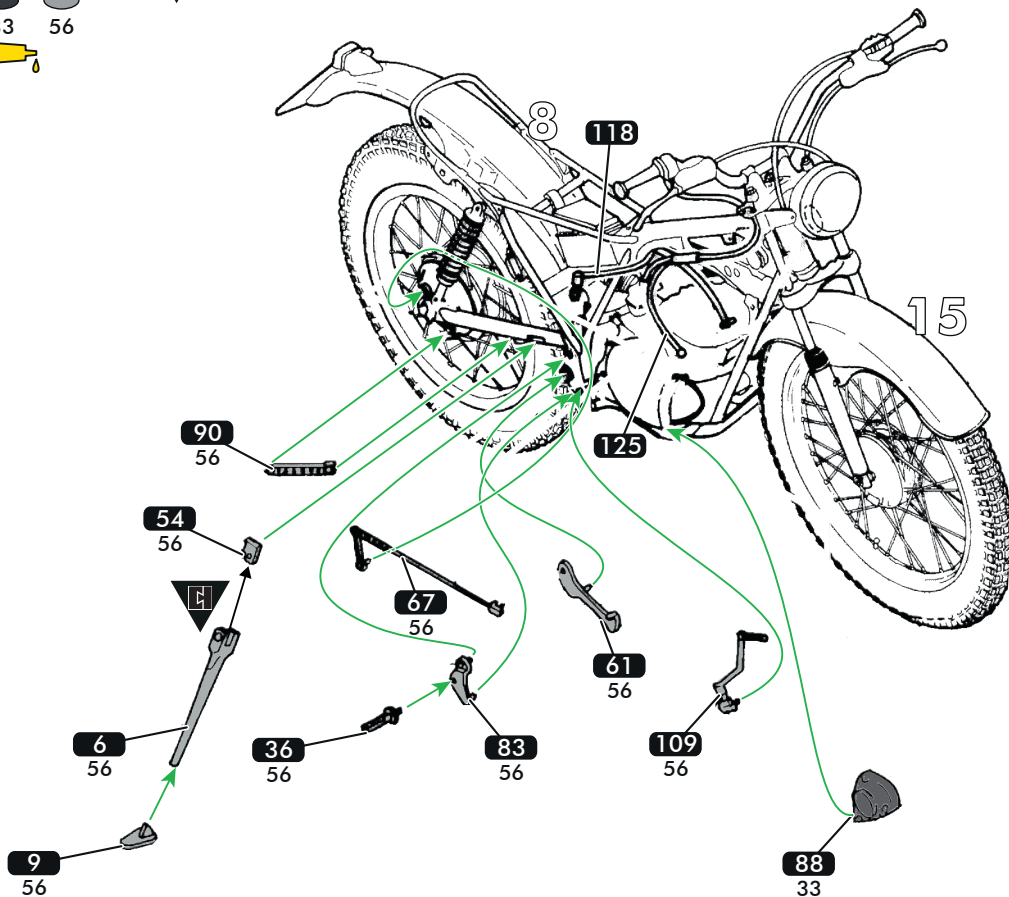
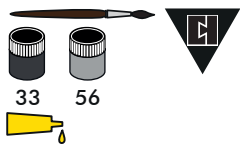

17

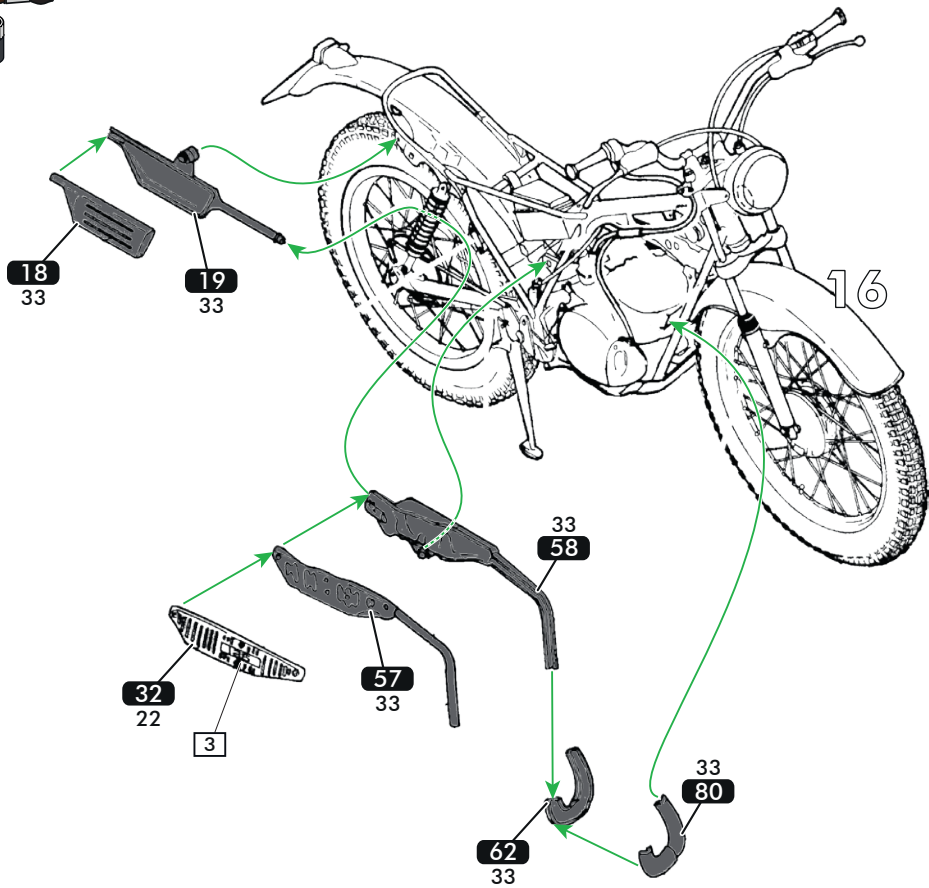
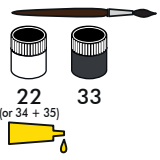

18

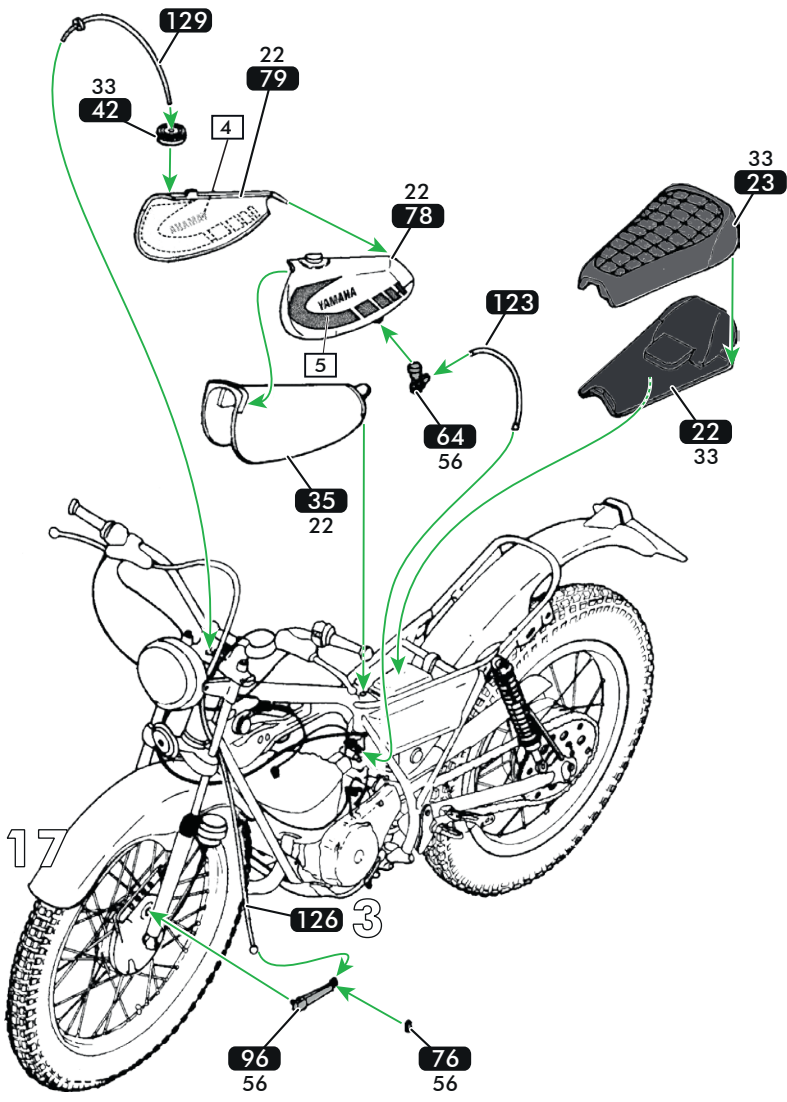
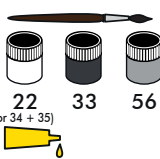



VISITEZ-NOUS SUR LES RÉSEAUX SOCIAUX

VISIT US ON SOCIAL MEDIA!
BESUCHE UNS AUF SOCIAL MEDIA!

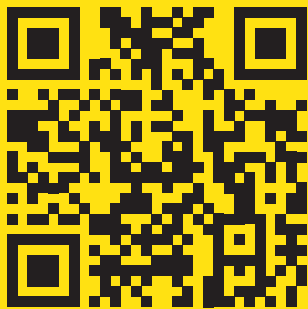

[instagram.com/heller.fr](https://www.instagram.com/heller.fr)

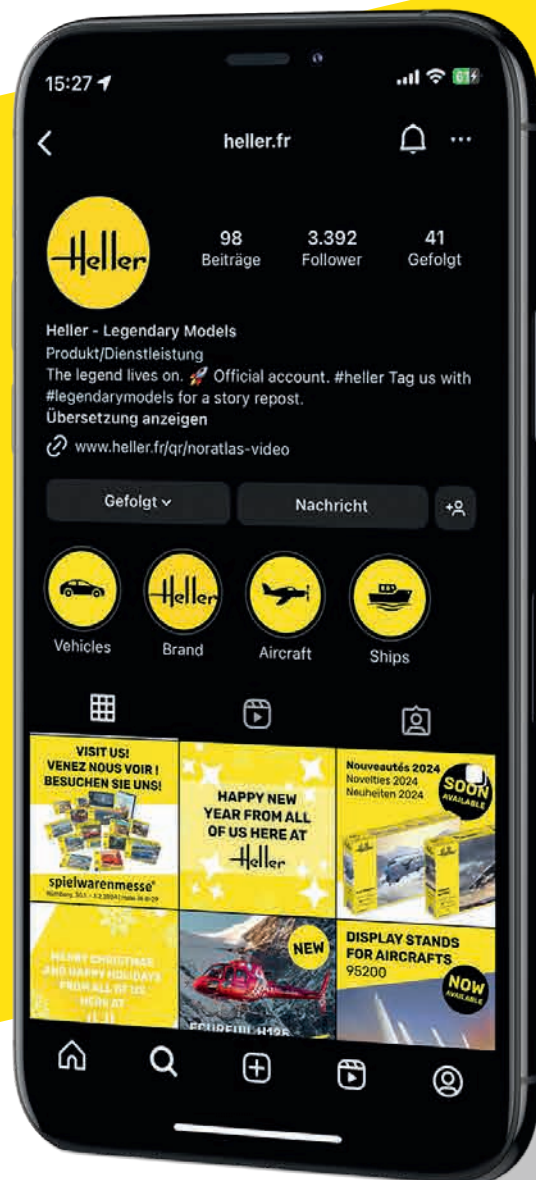

VISITEZ NOTRE SITE WEB ET NOTRE BOUTIQUE EN LIGNE !

VISIT OUR WEBSITE AND ONLINESHOP!

BESUCHE UNSERE WEBSITE UND ONLINESHOP!



**DOWNLOAD
INSTRUCTIONS**



**ORDER
SPARE
PARTS**

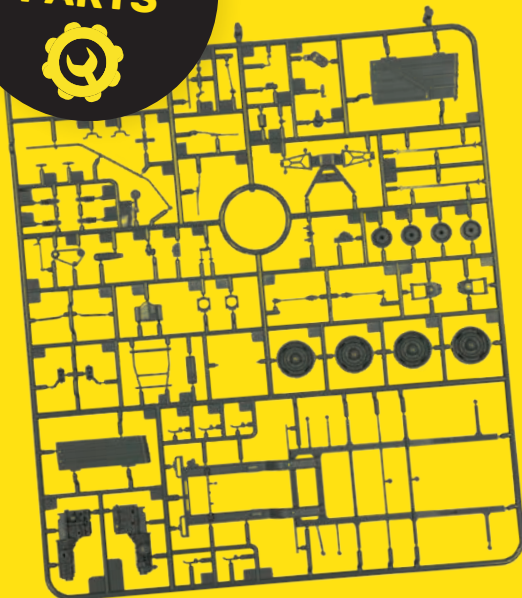

**SHOP
ONLINE**



V-300725

Heller Hobby GmbH | Erlenbacher Str. 3 | 42477 Radevormwald | Germany

+49 (0) 2195-92773-0 | www.heller.fr | info@heller.fr

[instagram.com/heller.fr](https://www.instagram.com/heller.fr) | [facebook.com/heller.fr](https://www.facebook.com/heller.fr)