

Heller

DIORAMA DUNKERQUE

30326



Français

La bataille de Dunkerque s'est déroulée en mai et juin 1940 pendant la campagne occidentale de la Seconde Guerre mondiale. La ville de Dunkerque, dans le nord de la France, était le dernier port d'évacuation des troupes britanniques déployées en France en 1939-1940 dans le cadre de la stratégie défensive initiale des Alliés occidentaux.

Le Laffly V15T était un véhicule tout-terrain à quatre roues motrices (4x4) produite en France de 1938 à 1940 pour tracter l'artillerie légère et servir de véhicule de reconnaissance et de liaison. Il a été développé par Laffly à partir de 1937 en réponse à un appel d'offres de l'armée française. Une livraison de 100 véhicules était prévue pour l'hiver 1939/40, destinés à être utilisés par les unités de cavalerie comme véhicules de remorquage du canon antichar de 25 mm .

L'idée de développer des canons antichars est née entre les deux guerres mondiales. Ils devaient avoir une vitesse initiale élevée pour éviter en tir direct la télémétrie et la correction. D'autre part, il devait avoir un grand champ de tir (déplacement horizontal) sans qu'il soit nécessaire de déplacer l'affût. Son poids devait être faible afin qu'il puisse être remorqué par de petits véhicules à chenilles sur tous les types de terrain ou par des transporteurs à grande vitesse sur les routes.

Pendant la Seconde Guerre mondiale, la Wehrmacht a utilisé de nombreux véhicules militaires capturés. Parmi eux, le Laffly V15T français souvent équipé du canon antichar de 25 mm d'origine française. Le Laffly a continué à être produit par l'usine Licorne pour les besoins de la Wehrmacht après la conquête de la France.

Le Laffly avait une vocation purement militaire et n'excellait pas en matière de confort, mais il était très performant sur les routes difficiles et pouvait souvent se frayer un chemin là où d'autres voitures s'enlisaient.

English

The Battle of Dunkirk took place in May and June 1940 during the Western Campaign of the Second World War. The northern French town of Dunkirk was the last port of evacuation for British troops deployed in France in 1939-1940 as part of the Western Allies' initial defensive strategy.

The Laffly V15T was a four-wheel drive (4x4) all-terrain vehicle produced in France from 1938 to 1940 to tow light artillery and serve as a reconnaissance and liaison vehicle. It was developed by Laffly from 1937 in response to an invitation to tender from the French Army.

A delivery of 100 vehicles to be used by cavalry units as towing vehicles for the 25mm anti-tank gun was planned for the winter of 1939/40.

The idea of developing anti-tank guns arose between the two world wars. They had to have a high initial velocity to avoid range finding and correction in direct fire. On the other hand, it had to have a large field of fire (horizontal displacement) without the need to move the mount. Its weight had to be low so that it could be towed by small tracked vehicles on all types of terrain or by high-speed transporters on roads.

During the Second World War, the Wehrmacht used many captured military vehicles. These included the French V15T Laffly, often fitted with the original French 25mm anti-tank gun. The Laffly continued to be produced by the Licorne factory for the needs of the Wehrmacht after the conquest of France.

The Laffly's purpose was purely military and it did not excel in comfort, but it was very good on difficult roads and could often get through where other cars got stuck.

Deutsch

Die Schlacht von Dünkirchen ereignete sich im Mai und Juni 1940 im Zuge des Westfeldzugs während des Zweiten Weltkrieges. Die nordfranzösische Stadt Dünkirchen war der letzte Evakuierungshafen der Britischen Truppen, die 1939/1940 in Frankreich als Teil der zunächst defensiven Strategie der Westalliierten eingesetzt worden war.

Der Laffly V15T war ein geländegängiges Fahrzeug mit Allradantrieb (4x4), das von 1938 bis 1940 in Frankreich hergestellt wurde, um leichte Artillerie zu ziehen und als Aufklärungs- und Verbindungsfahrzeug zu dienen. Er wurde ab 1937 von Laffly aufgrund der Ausschreibung des französischen Heeres entwickelt. Für den Winter 1939/40 war eine Lieferung von 100 Fahrzeugen vorgesehen, die von Kavallerieeinheiten als Schleppfahrzeuge für die 25 mm Panzerabwehrkanone eingesetzt werden sollten.

Die Idee, Panzerabwehrkanonen zu entwickeln, entstand zwischen den beiden Weltkriegen.

Sie sollten eine hohe Mündungsgeschwindigkeit haben, um bei einem Direktschuss die Telemetrie und die Korrektur zu vermeiden.

Das sind zwei Vorgänge, die bei einer "traditionellen" Kanone den Beginn des Schusses verzögern und eine gute Durchschlagskraft garantieren und andererseits ein großes Schussfeld (horizontale Verschiebung) haben, ohne die Lafette bewegen zu müssen. Ihr Gewicht musste gering sein, um von kleinen Raupenfahrzeugen auf allen Geländen oder von Schnelltransportern mit hoher Geschwindigkeit auf der Straßen gezogen werden zu können.

Während des Zweiten Weltkriegs setzte die Wehrmacht zahlreiche erbeutete Militärfahrzeuge ein.

Dazu gehörte auch der französische Laffly V15T, der häufig mit der aus Frankreich stammenden 25 mm Panzerabwehrkanone ausgerüstet war. Der Laffly wurde auch nach der Eroberung Frankreichs im Werk Licorne für den Bedarf der Wehrmacht weiter produziert.

Der Zweck des Laffly war rein militärisch und zeichnete sich nicht durch Komfort aus, aber er war sehr gut auf schwierigen Straßen zu fahren und konnte oft dort durchfahren, wo andere Autos stecken blieben.

Español

La batalla de Dunkerque tuvo lugar entre mayo y junio de 1940, durante la campaña occidental de la Segunda Guerra Mundial. La ciudad de Dunkerque, en el norte de Francia, fue el último puerto de evacuación de las tropas británicas desplegadas en Francia en 1939-1940 como parte de la estrategia defensiva inicial de los aliados occidentales.

El Laffly V15T era un vehículo todoterreno con tracción a las cuatro ruedas (4x4) producido en Francia entre 1938 y 1940 para remolcar artillería ligera y servir como vehículo de reconocimiento y enlace. Fue desarrollado por Laffly a partir de 1937 en respuesta a una oferta de licitación del ejército francés. Se había previsto una entrega de 100 vehículos para el invierno de 1939/40, destinados a ser utilizados por las unidades de caballería como vehículos de remolque del cañón antitanque de 25 mm.

La idea de desarrollar cañones antitanque nació en el período de entreguerras. Debían tener una gran velocidad inicial para evitar la localización de distancias y la corrección en fuego directo. Por otro lado, debían tener un gran campo de tiro (desplazamiento horizontal) sin necesidad de desplazarse. Su peso debía ser bajo para que pudiera ser remolcado por vehículos pequeños con orugas en todo tipo de terreno o por transportadores de alta velocidad en carretera.

Durante la Segunda Guerra Mundial, la Wehrmacht utilizó numerosos vehículos militares capturados. Entre ellos, el Laffly V15T francés, a menudo equipado con el cañón antitanque de 25 mm de origen francés. El Laffly siguió siendo producido por la fábrica de Licorne para las necesidades de la Wehrmacht después de la ocupación de Francia.

El Laffly tenía una vocación puramente militar y no sobresalía en términos de comodidad, pero tenía un gran rendimiento en rutas difíciles y, a menudo, podía abrirse camino donde otros automóviles se quedaban atascados.

Italiano

La battaglia di Dunkerque si è svolta tra il maggio e il giugno 1940 nell'ambito della campagna occidentale della Seconda Guerra mondiale. La città di Dunkerque, nel nord della Francia, è stato l'ultimo porto di evacuazione delle truppe britanniche schierate in Francia nel 1939-1940 come parte della strategia difensiva iniziale degli Alleati occidentali.

Il Laffly V15T era un fuoristrada a quattro ruote motrici (4x4) prodotto in Francia dal 1938 al 1940 per trainare l'artiglieria leggera e fungere da veicolo di ricognizione e collegamento. Venne sviluppato da Laffly nel 1937 dopo aver vinto una gara d'appalto dell'esercito francese. Per l'inverno 1939/40 era prevista una consegna di 100 veicoli, destinati ad essere utilizzati dalle unità di cavalleria come veicoli di traino del cannone anticarro da 25 mm.

L'idea di sviluppare cannoni anticarro era nata tra le due guerre mondiali. Requisito fondamentale era un'elevata velocità iniziale per evitare la necessità di dover effettuare calcoli di telemetria e la correzione nel tiro diretto. Inoltre, doveva avere un ampio campo di tiro (spostamento orizzontale) senza la necessità di spostare l'affusto. Il peso doveva essere ridotto per poter essere trainato da piccoli cingolati su tutti i tipi di terreno o da trasportatori ad alta velocità sulle strade.

Durante la Seconda Guerra mondiale, la Wehrmacht ha utilizzato numerosi veicoli militari presi dal nemico. Tra questi, il Laffly V15T francese spesso equipaggiato con il cannone anticarro da 25 mm anch'esso francese. Il Laffly ha continuato a essere prodotto nello stabilimento Licorne per coprire le esigenze della Wehrmacht dopo la conquista della Francia.

Il Laffly aveva una vocazione puramente militare e non eccelleva in termini di comfort, ma era molto performante sui fondi stradali sconnessi che riusciva a percorrere senza impantanarsi come molti altri veicoli.

Nederlands

De Slag om Duinkerken vond plaats in mei en juni 1940 tijdens de Westerse Campagne van de Tweede Wereldoorlog. De stad Duinkerken in Noord-Frankrijk was de laatste evacuatiehaven voor de Britse troepen die in 1939-1940 in Frankrijk werden ingezet als onderdeel van de aanvankelijke defensieve strategie van de westerse geallieerden.

De Laffly V15T was een vierwielangedreven (4x4) terreinvoertuig dat van 1938 tot 1940 in Frankrijk werd geproduceerd om lichte artillerie te slepen en als verkennings- en verbindingsvoertuig te dienen. Het werd vanaf 1937 door Laffly ontwikkeld naar aanleiding van een aanbesteding van het Franse leger. Een levering van 100 voertuigen was gepland voor de winter 1939/40 om te worden gebruikt door cavalerie-eenheden als sleepvoertuigen voor het 25 mm antitankkanon.

Het idee om antitankkanonnen te ontwikkelen ontstond tussen de twee wereldoorlogen. Ze moesten een hoge beginsnelheid hebben om telemetrie en correctie bij direct vuur te voorkomen. Aan de andere kant moest het een groot schietbereik hebben (horizontale verplaatsing) zonder dat de affuit verplaatst hoefde te worden. Het moest licht genoeg zijn om getrokken te worden door kleine rupsvoertuigen over alle soorten terrein, of door hogesnelheidstransporters over de weg.

Tijdens de Tweede Wereldoorlog gebruikte de Wehrmacht veel buitgemaakte militaire voertuigen. Onder hen de Franse V15T Laffly, vaak uitgerust met het 25 mm antitankkanon van Franse makelij. De Laffly werd nog steeds geproduceerd door de Licorne-fabriek voor de behoeften van de Wehrmacht na de verovering van Frankrijk.

De Laffly had een puur militaire functie en blonk niet uit in comfort, maar hij presteerde erg goed op moeilijke wegen en kon zich vaak een weg banen waar andere auto's vastliepen.

1/35

DIORAMA DUNKERQUE

30326



5
Gris fonce brillant
Dark Admiralty Grey Gloss
Dunkelgrau glänzend



11
Argent métallique
Silver Metallic
Silber metallisch



16
Or métallique
Gold Metallic
Gold metallisch



19
Rouge vif brillant
Bright Red Gloss
Hellrot glänzend



24
Jaune entraînement mat
Trainer Yellow Matt
Trainergelb matt



27
Gris mer mat
Sea Grey Matt
Seegrü mat



53
Gris métallique
Gunmetal Metallic
Grau metallisch



56
Aluminium métallique
Aluminium Metallic
Aluminium metallisch



60
Ecarlate mat
Scarlet Matt
Scharlachrot matt



61
Chair mat
Flesh Matt
Hautfarbe matt



66
Gris brun olive mat
Olive Drab Matt
Olivgrün matt



70
Rouge brique mat
Brick Red Matt
Ziegelrot matt



80
Vert pré mat
Grass Green Matt
Grasgrün matt



85
Noir de charbon satiné
Coal Black Satin
Kohlenschwarz seidenmatt



86
Olive clair mat
Light Olive Matt
Olivgrün hell matt



92
Gris fer mat
Iron Grey Matt
Eisengrau matt



93
Jaune desert mat
Desert Yellow Matt
Wüstensand matt



102
Vert armée mat
Army Green Matt
Armeegrün matt



110
Bois naturel mat
Natural Wood Matt
Naturholz matt



113
Rouille mat
Rust Matt
Rost matt



119
Terre claire mat
Light Earth Matt
Erde hell matt



186
Brun mat
Brown Matt
Braun matt



M1
5 + 93



M2
16 + 19

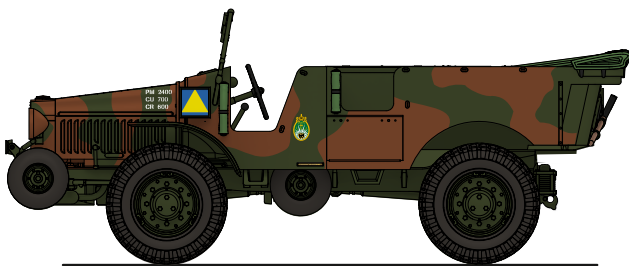

a 2^{ème} DLM Division Légère Mécanique, 13^{ème}
Rgt de Dragons, 12^{ème} EDAC (Escadron Divisionnaire Anti Char)
2nd DLM Division Légère Mécanique, 13th
Rgt de Dragons, 12th EDAC (Divisional Anti-Tank Squadron)

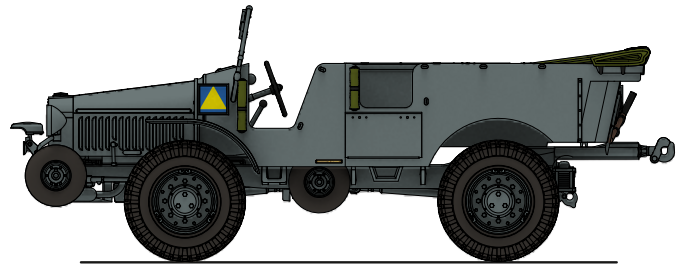

b Allemagne: LAFFLY (f) type V15T, 1941
Germany: LAFFLY (f) V15T type, 1941

- Si aucune teinte n'est spécifiée, peindre dans les couleurs de la version choisie. Se reporter aux pages 21 - 22 pour le détail du schéma de peinture.
- When no color is specified, paint the item with colors of chosen version. Refer to pages 21 - 22 for painting pattern.
- Wenn keine Farbe angegeben ist, Teile mit den Farben der gewählten Version bemalen. Beachten Sie die Seiten 21 - 22 für die Lackierung und Markierung.
- Cuando ningún color es especificado, pintarle con los colores del tema de la versión elegida. Vea las páginas 21 - 22 para obtener detalles de pintura.

2

Numéro de phase
Step number
Schrittnummer
Número de fase

56

Référence de couleur
Colour reference no
Farbangabe
Referencia de color

37

Numéro de pièce
Part number
Teilenummer
Número de pieza

6

Numéro de decal
Decal number
Abziehbildnummer
Número de calcomanía

1  

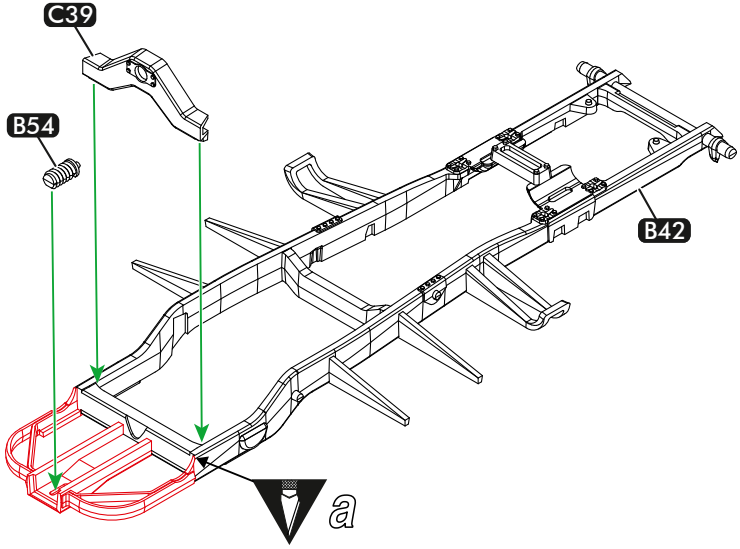

2 

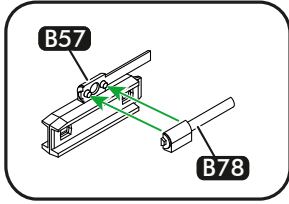
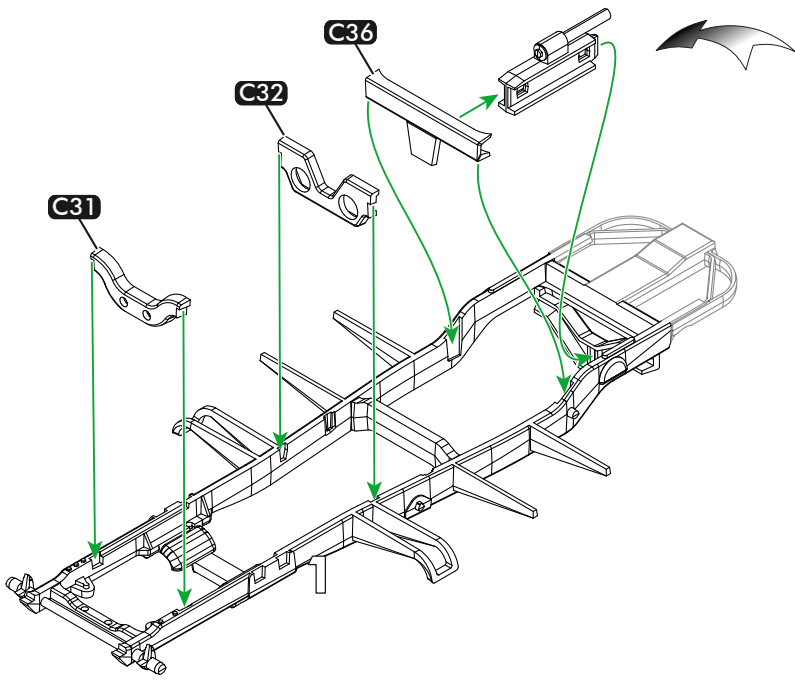

3 

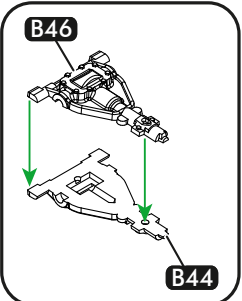
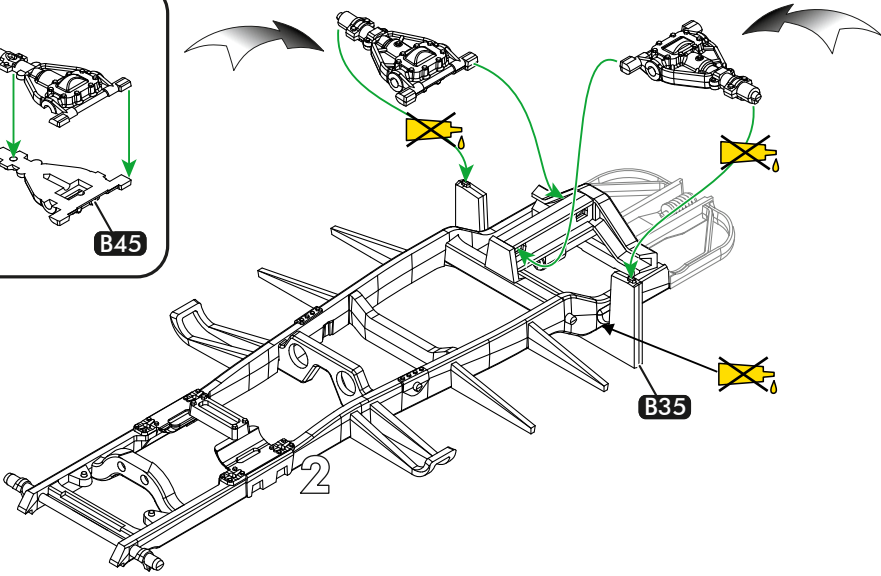
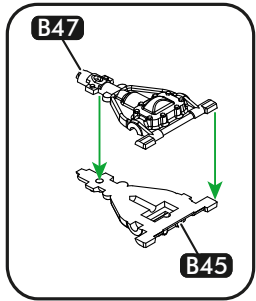

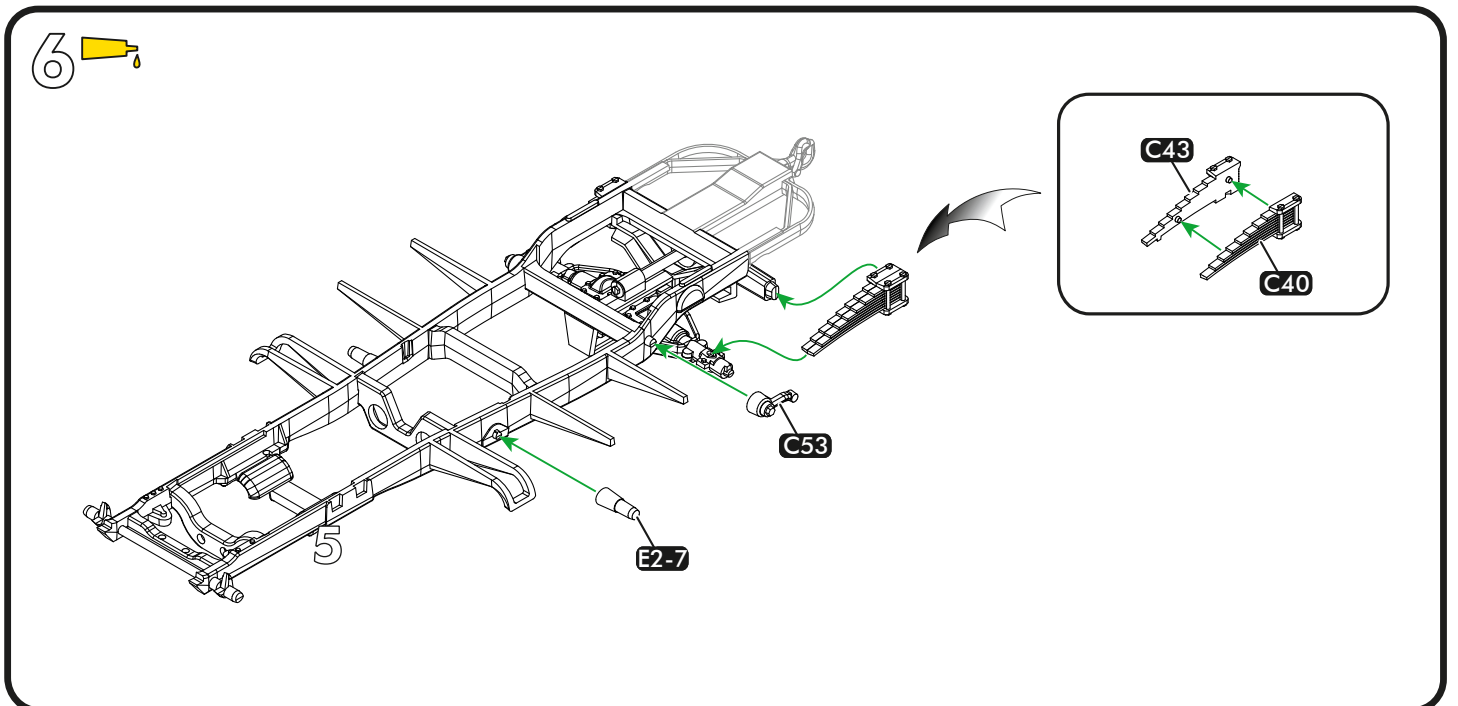
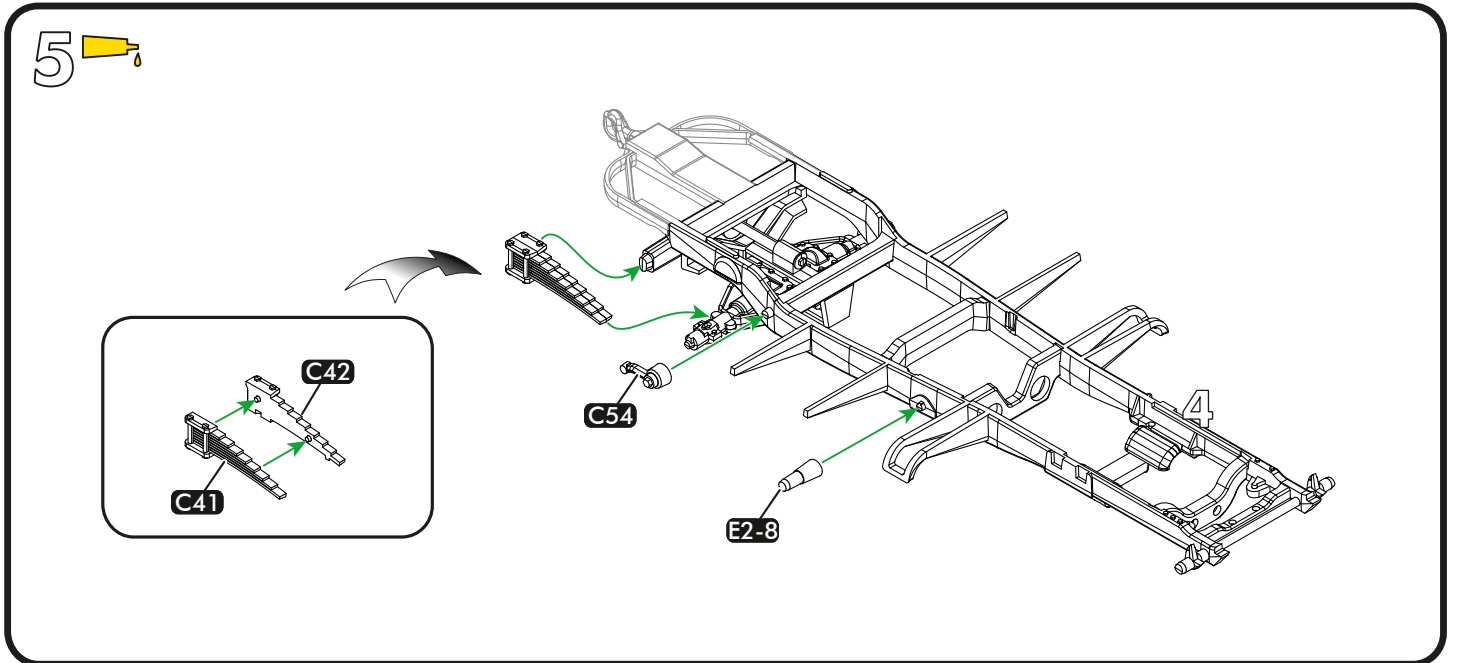
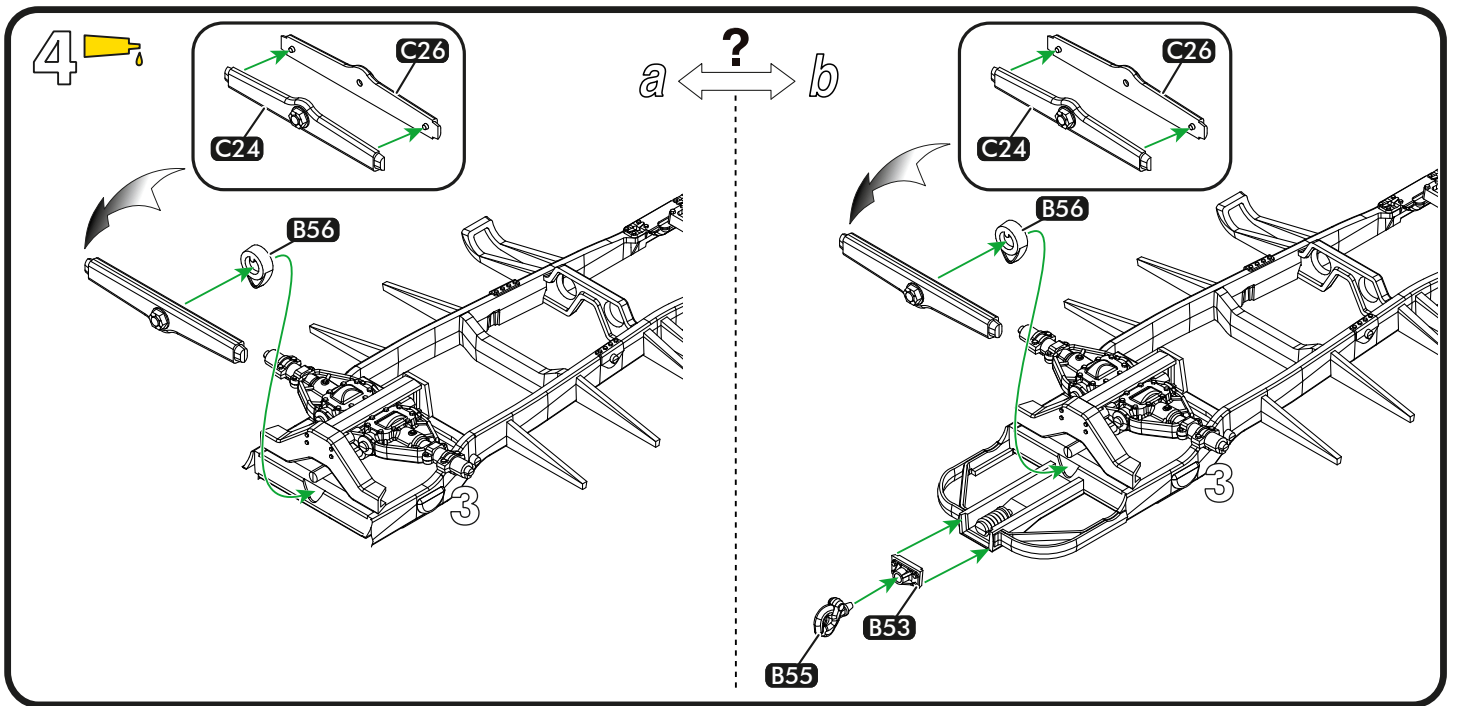

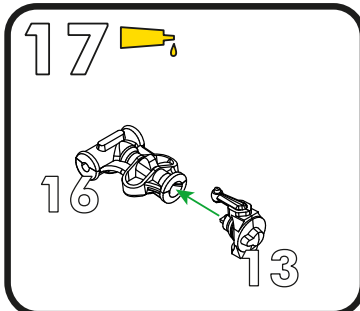
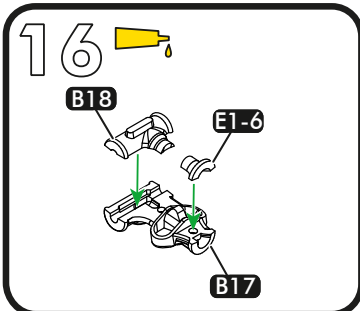
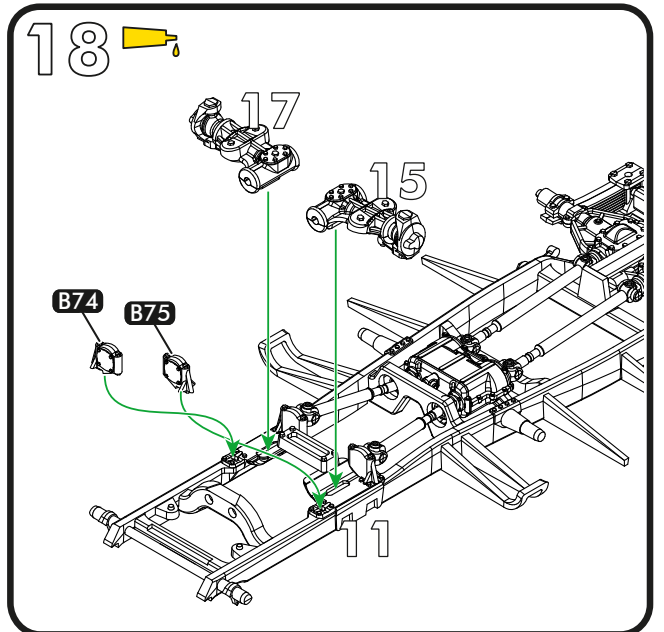
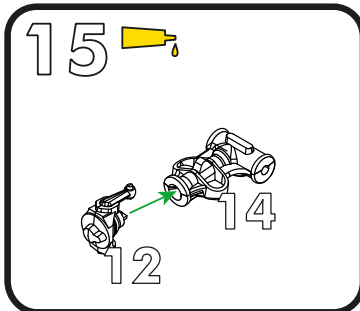
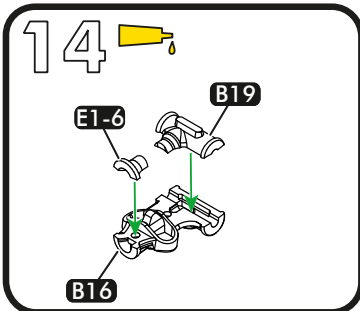
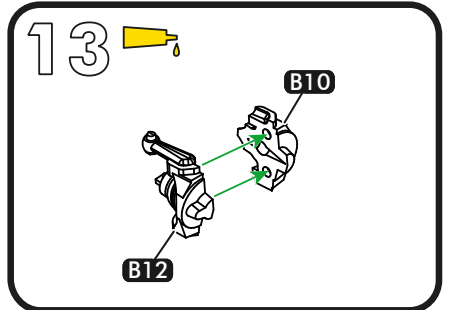
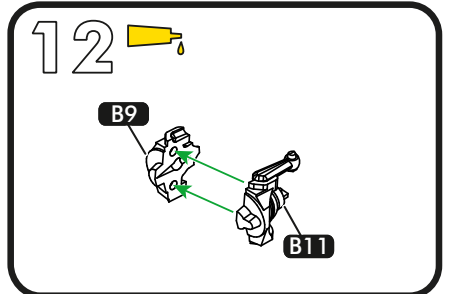
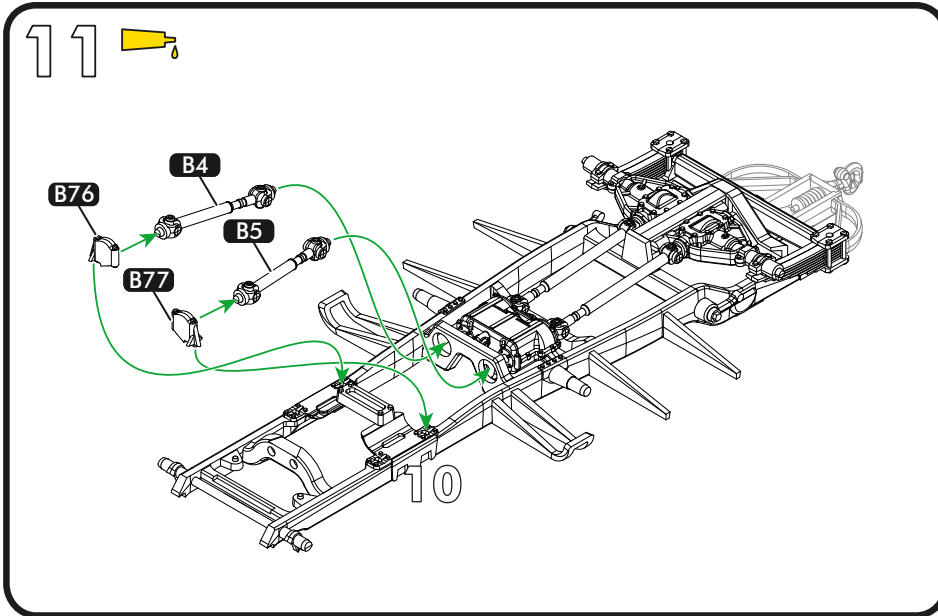
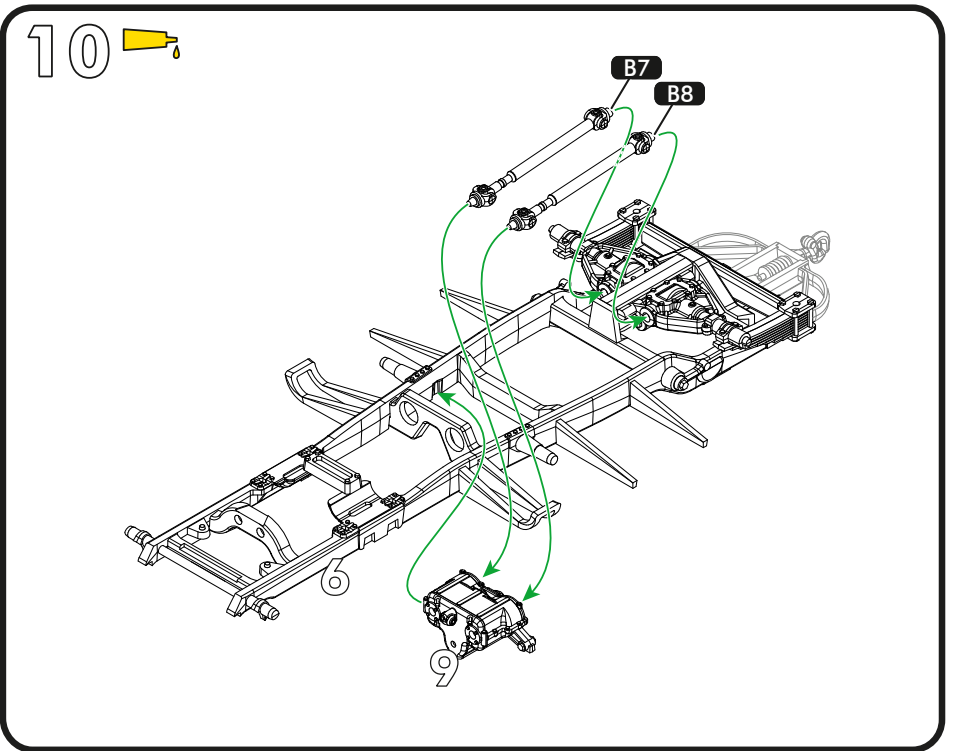
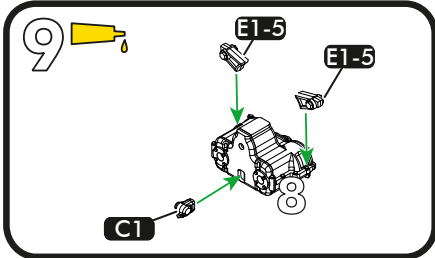
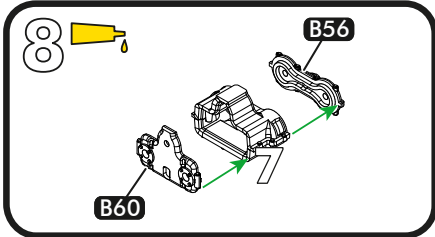
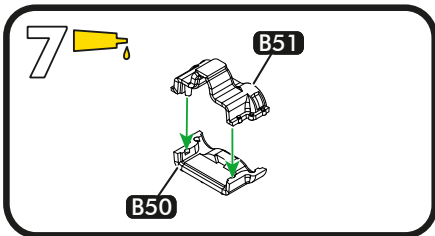

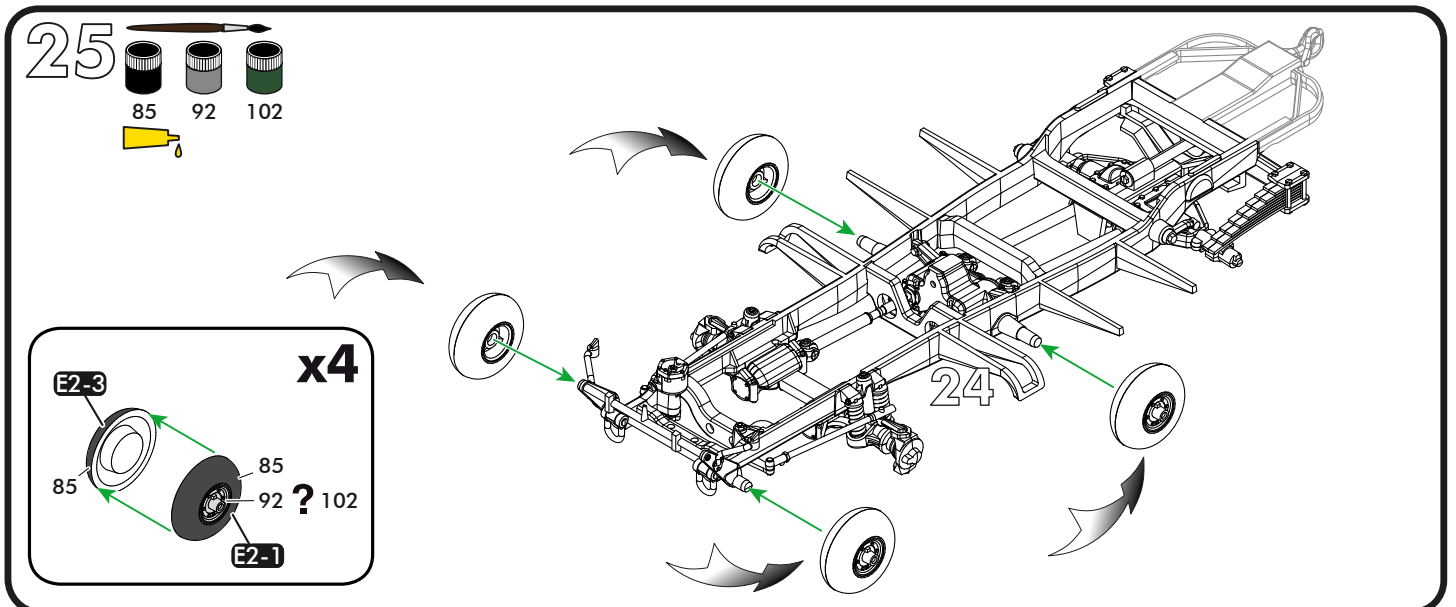
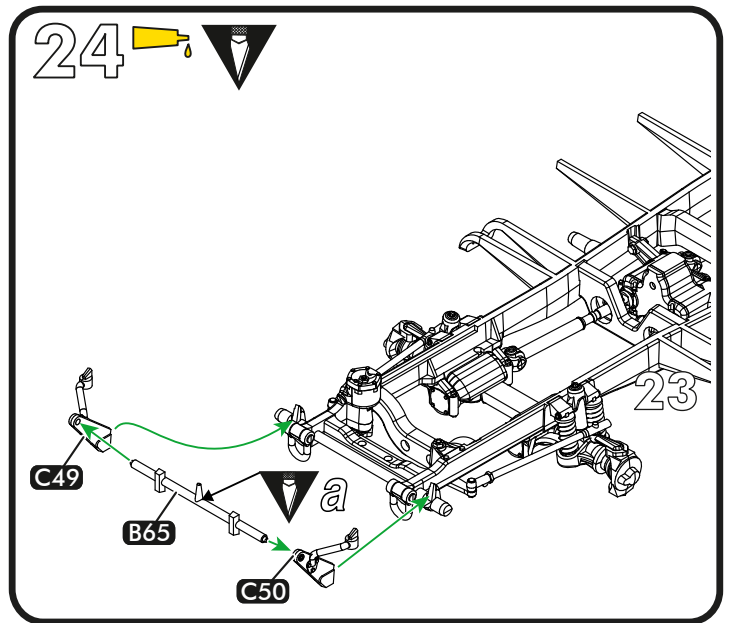
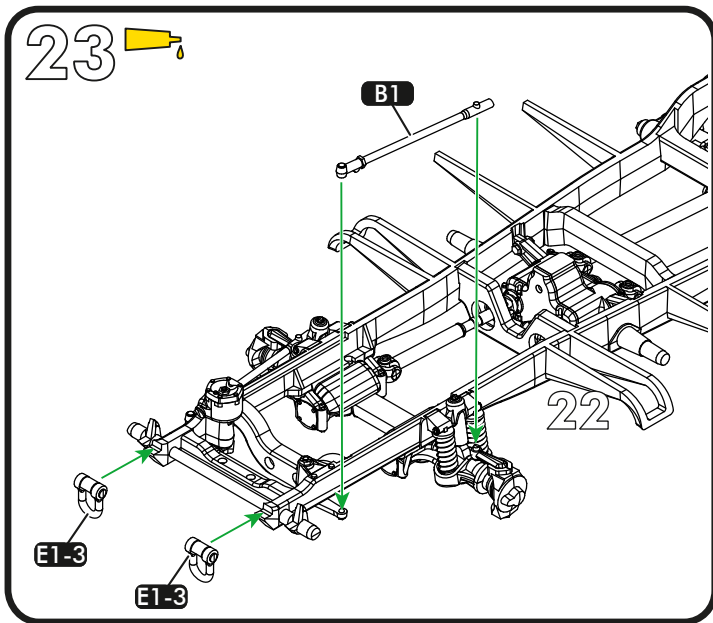
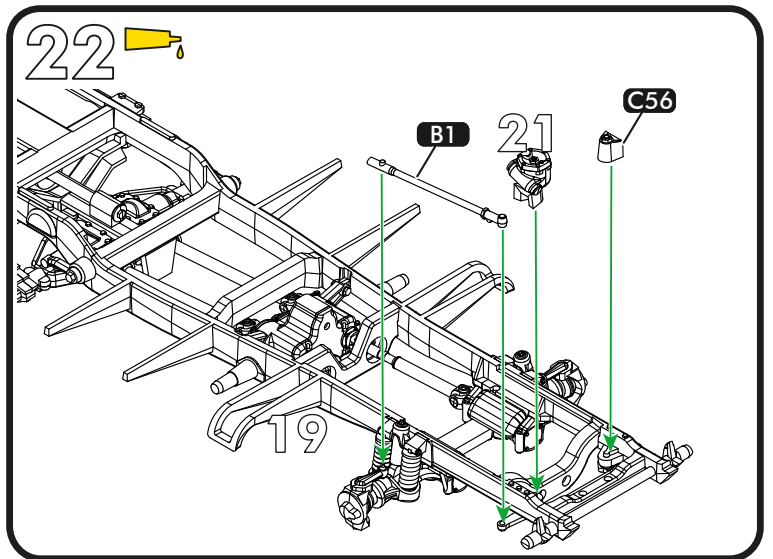
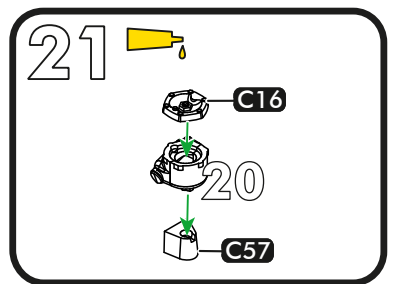
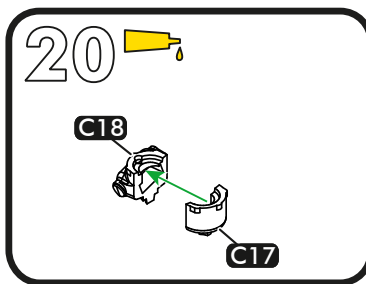
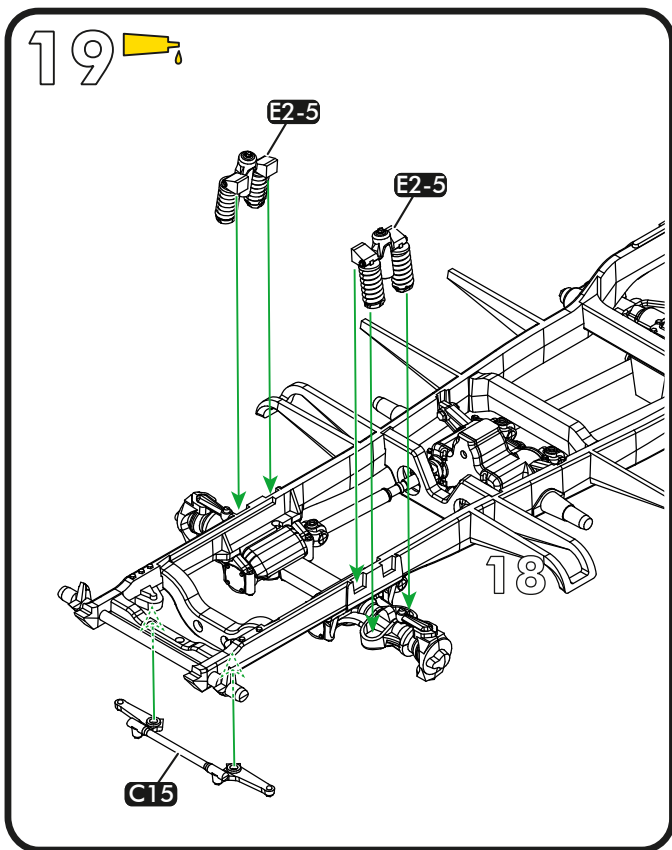

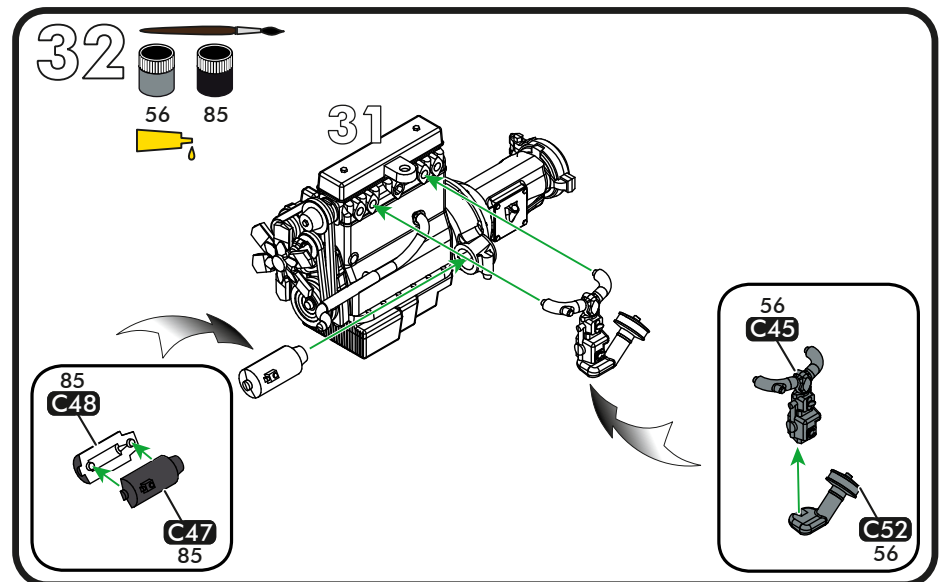
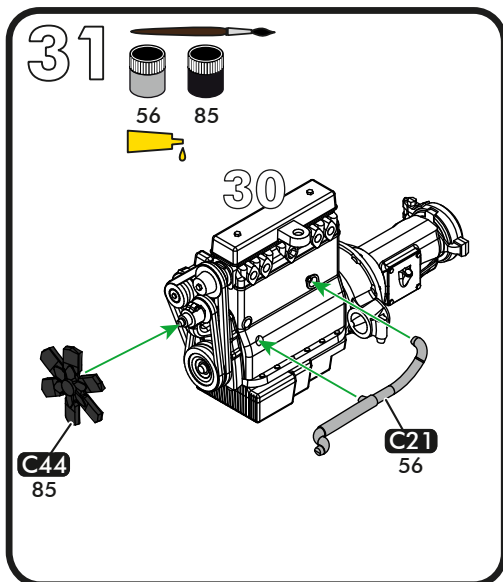
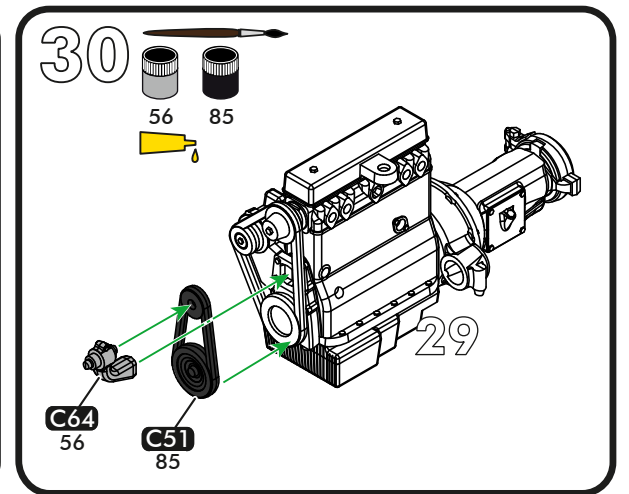
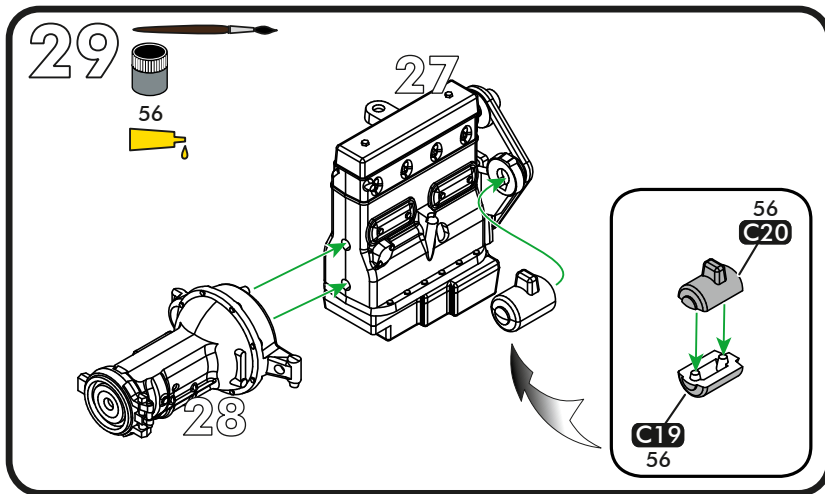
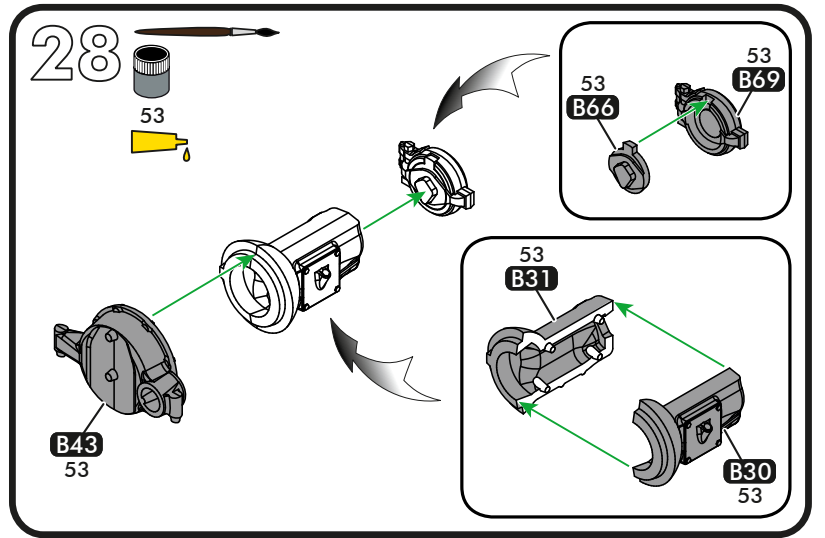
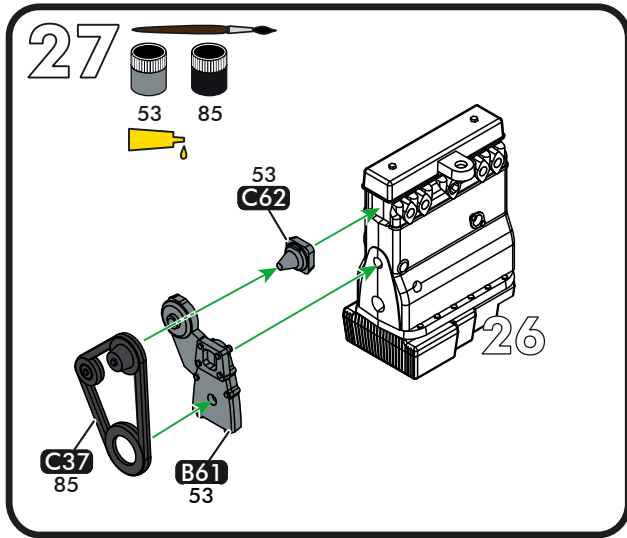
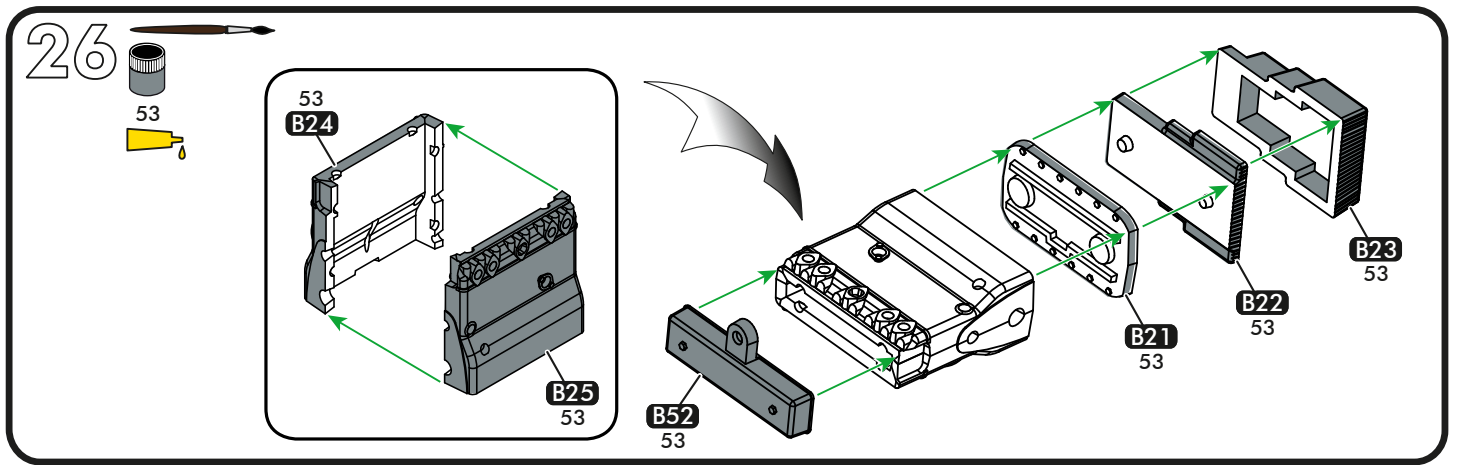

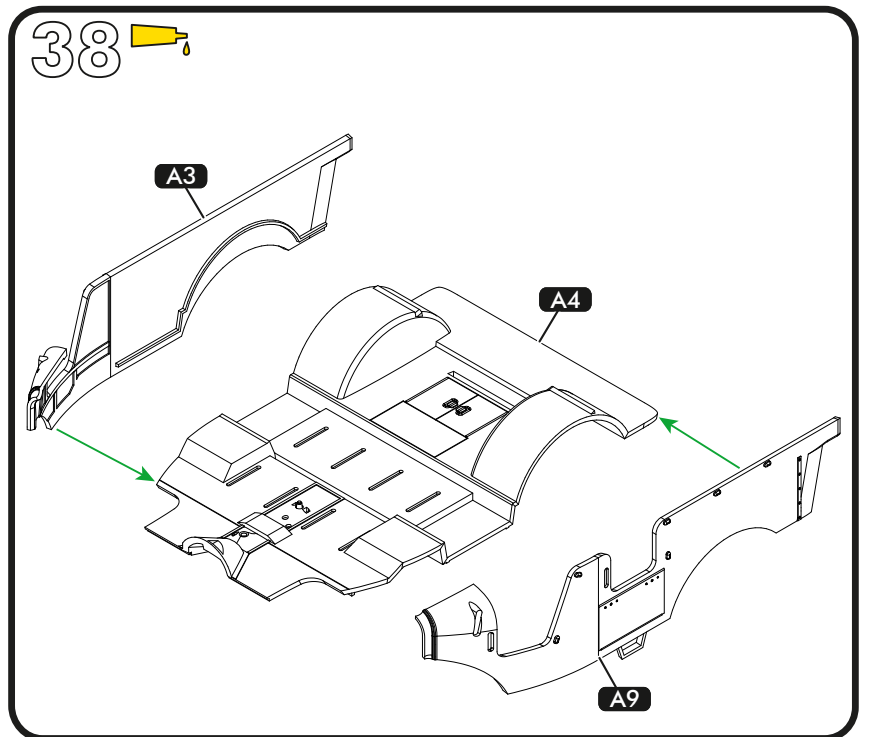
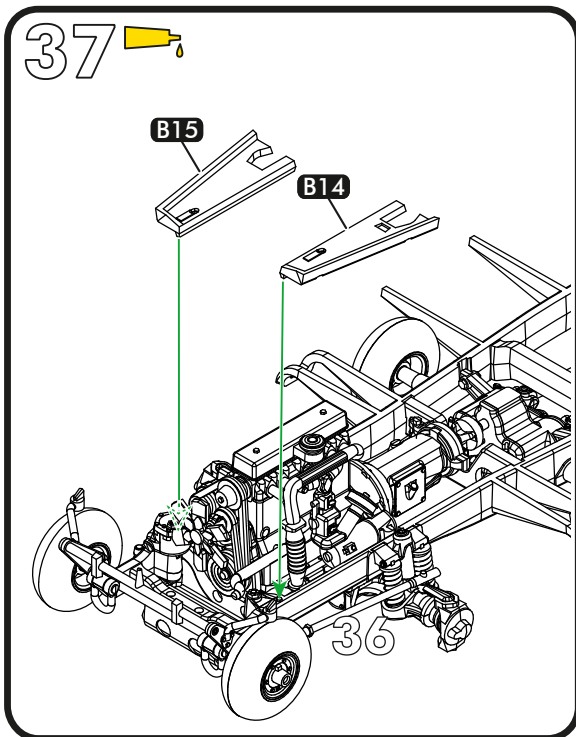
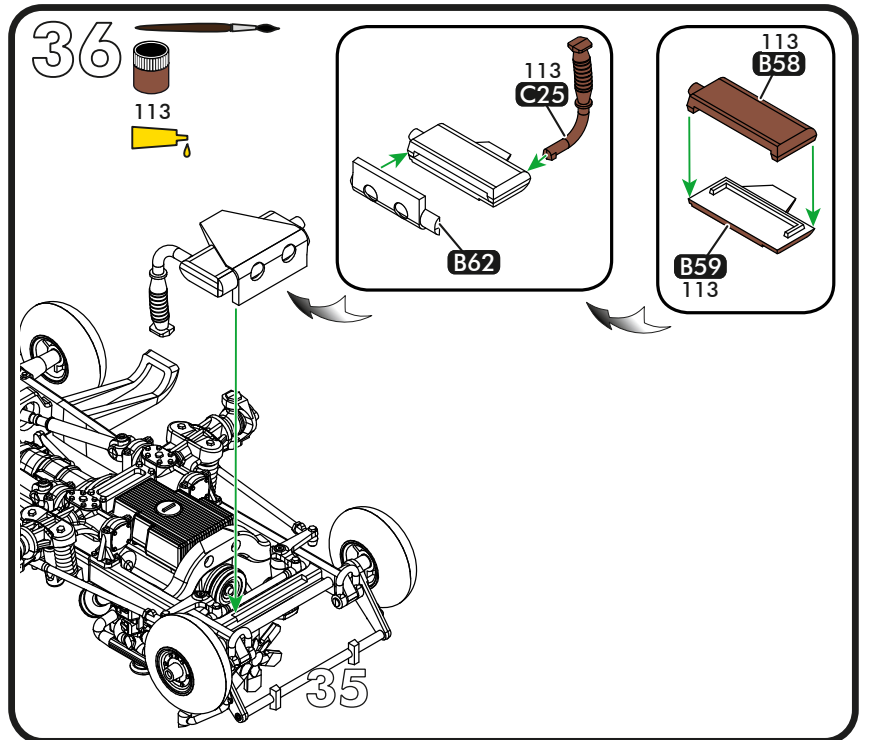
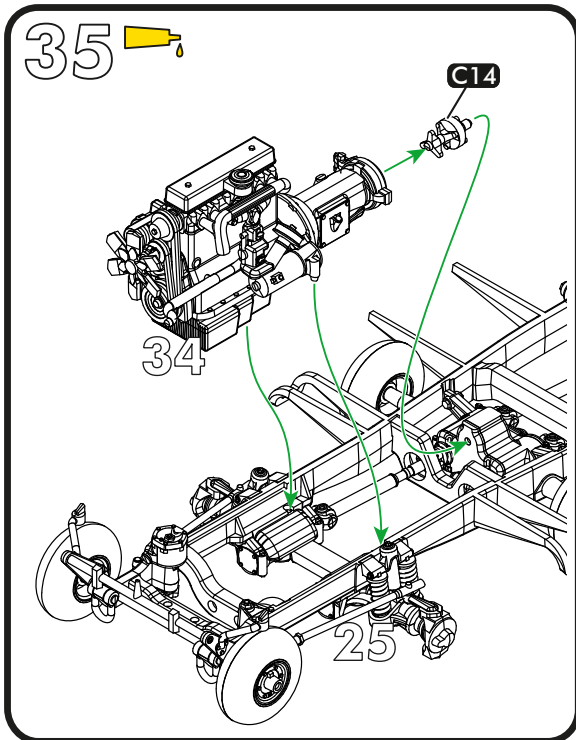
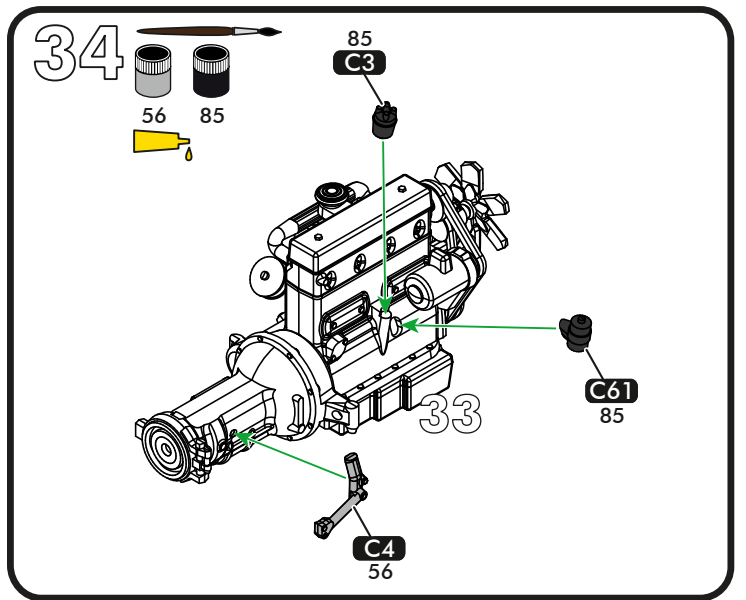
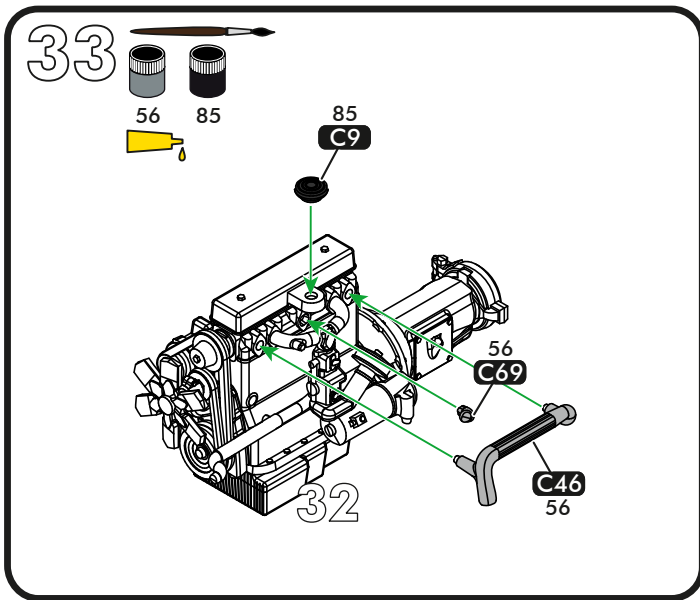

39 

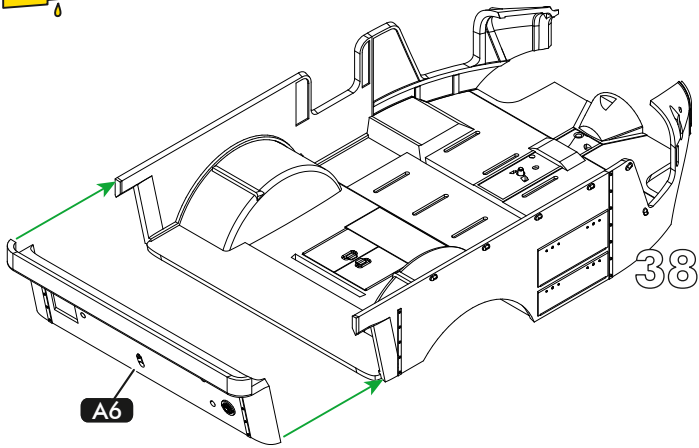

40 

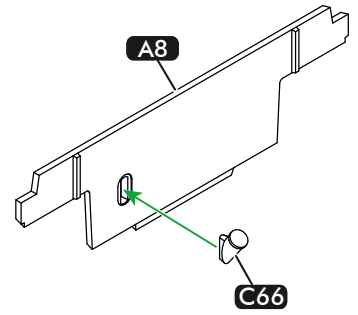

41 

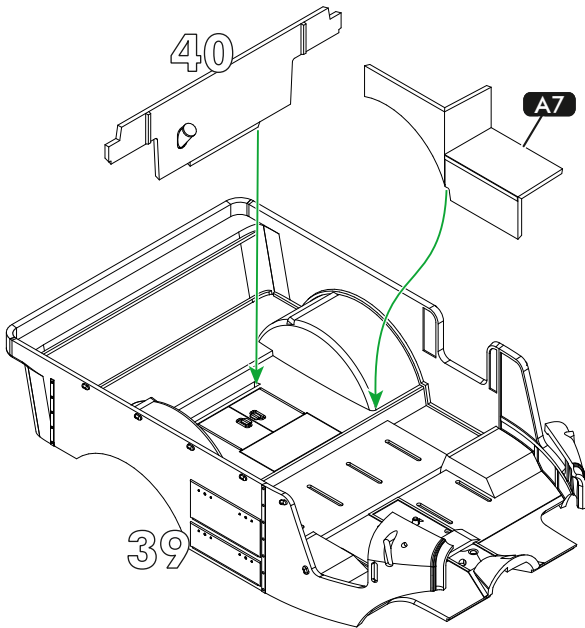

42 

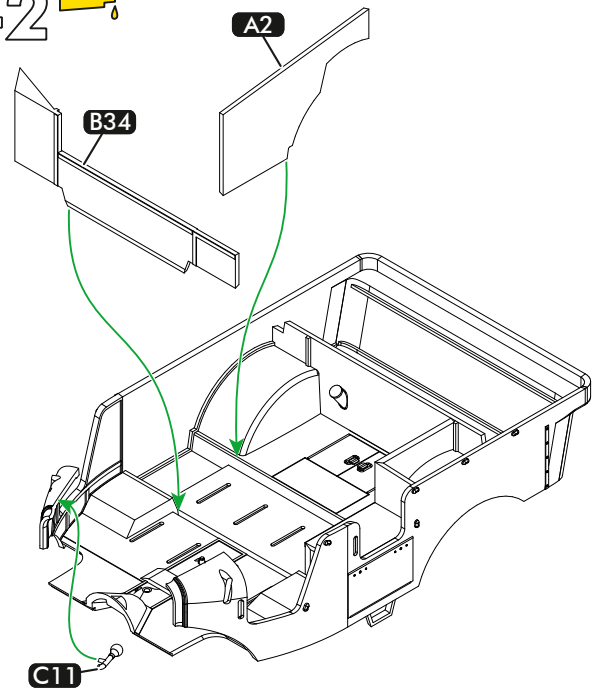

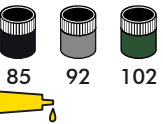
43 

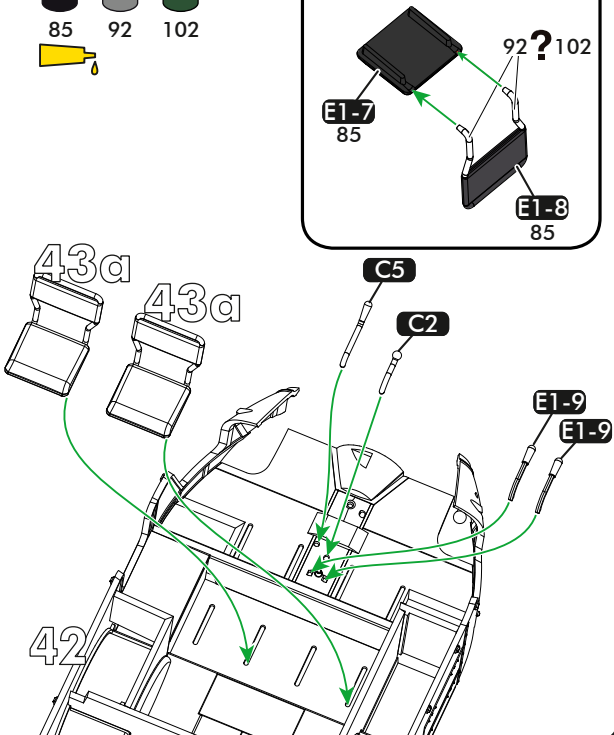

43a x4

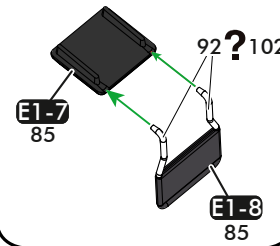

44 

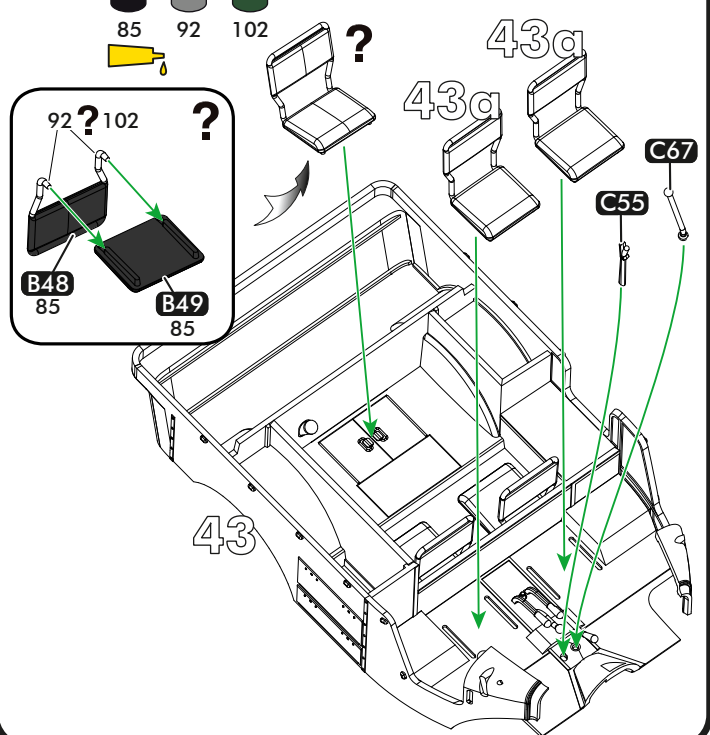

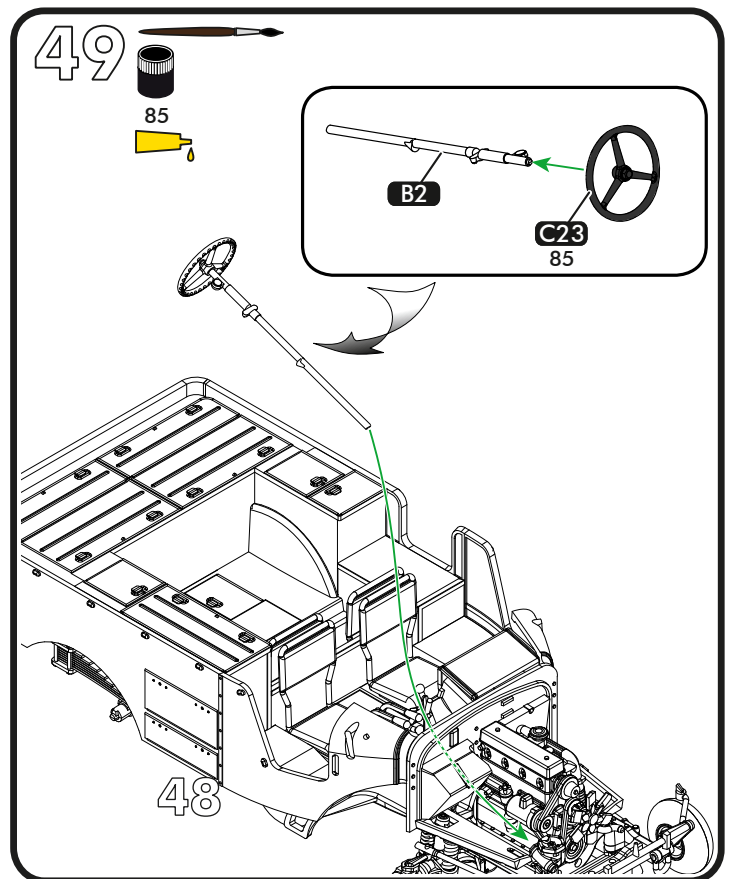
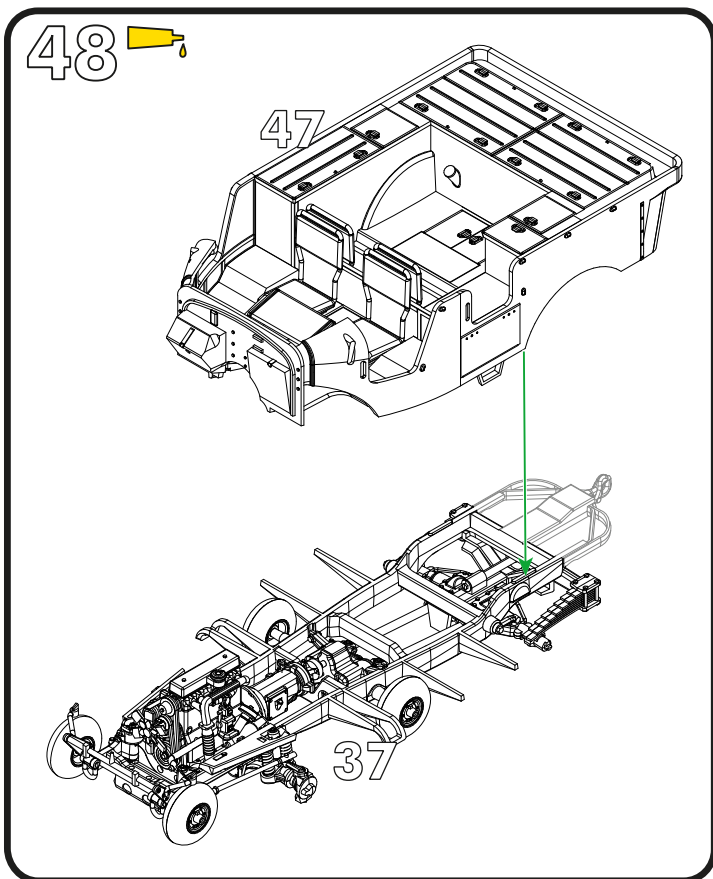
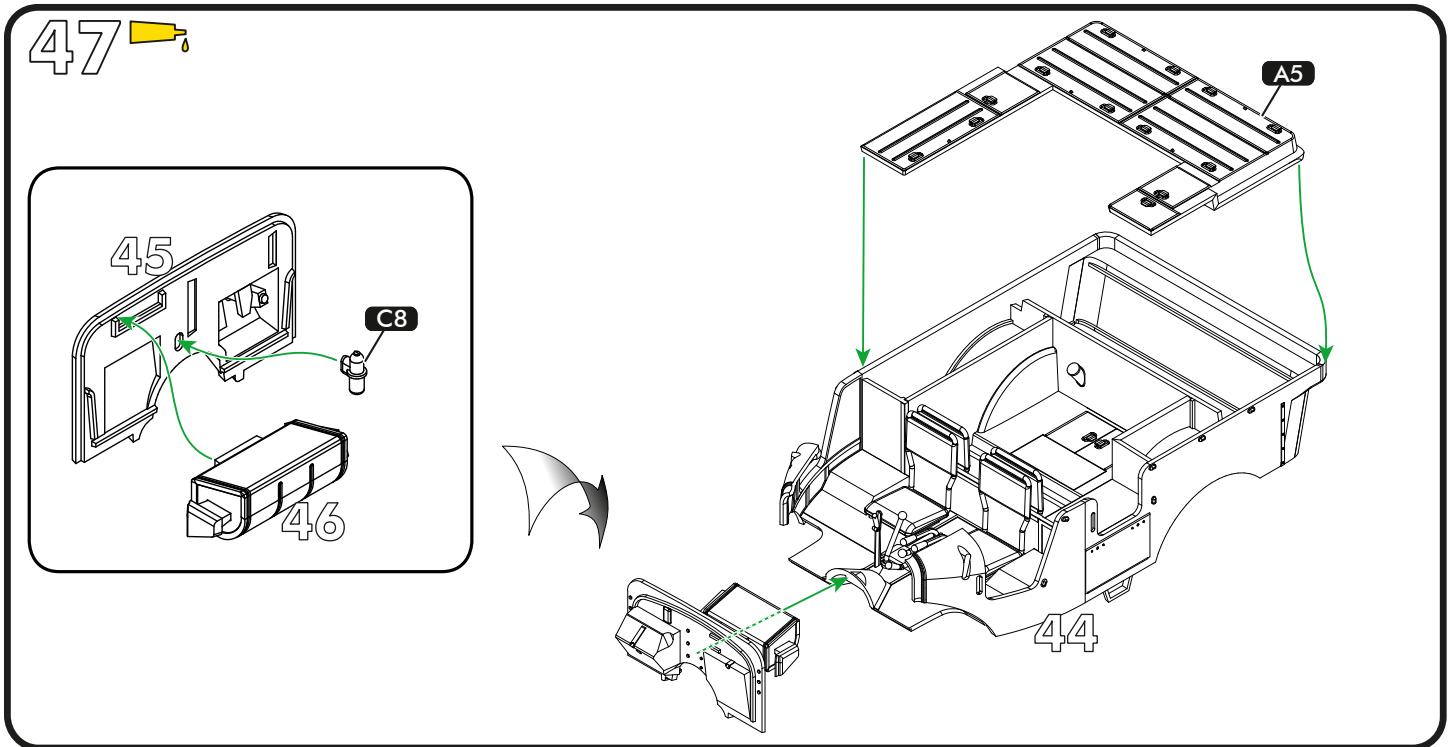
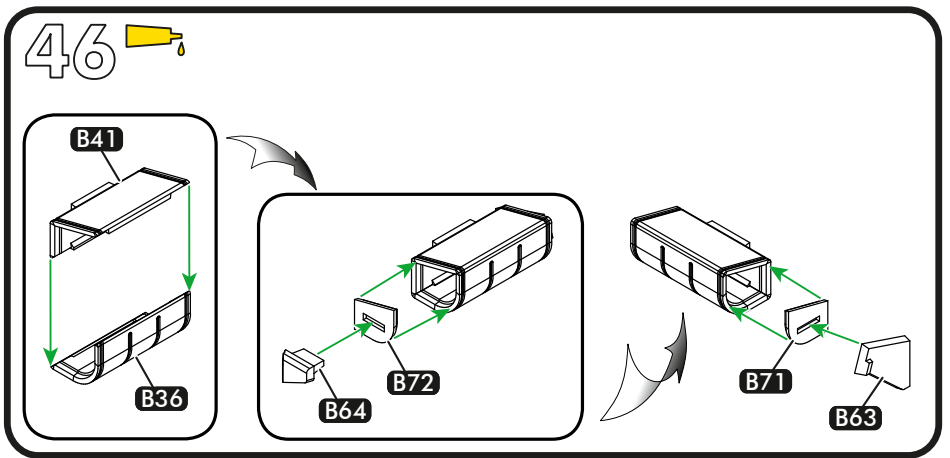
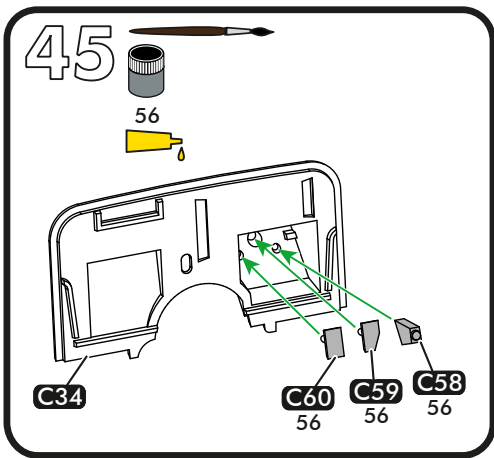

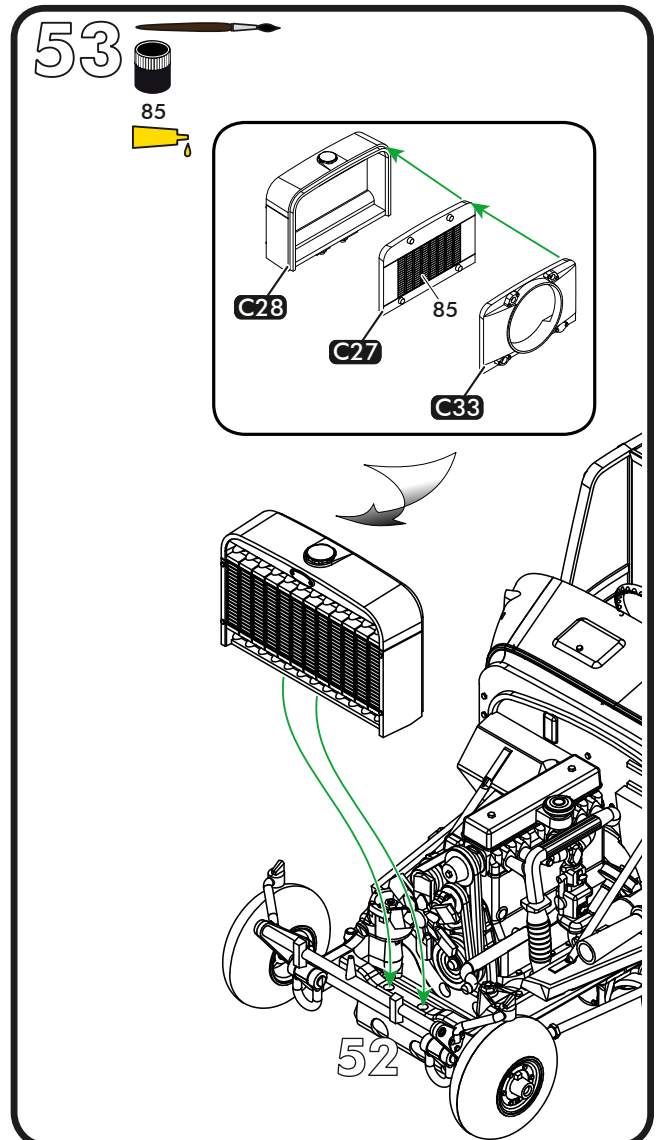
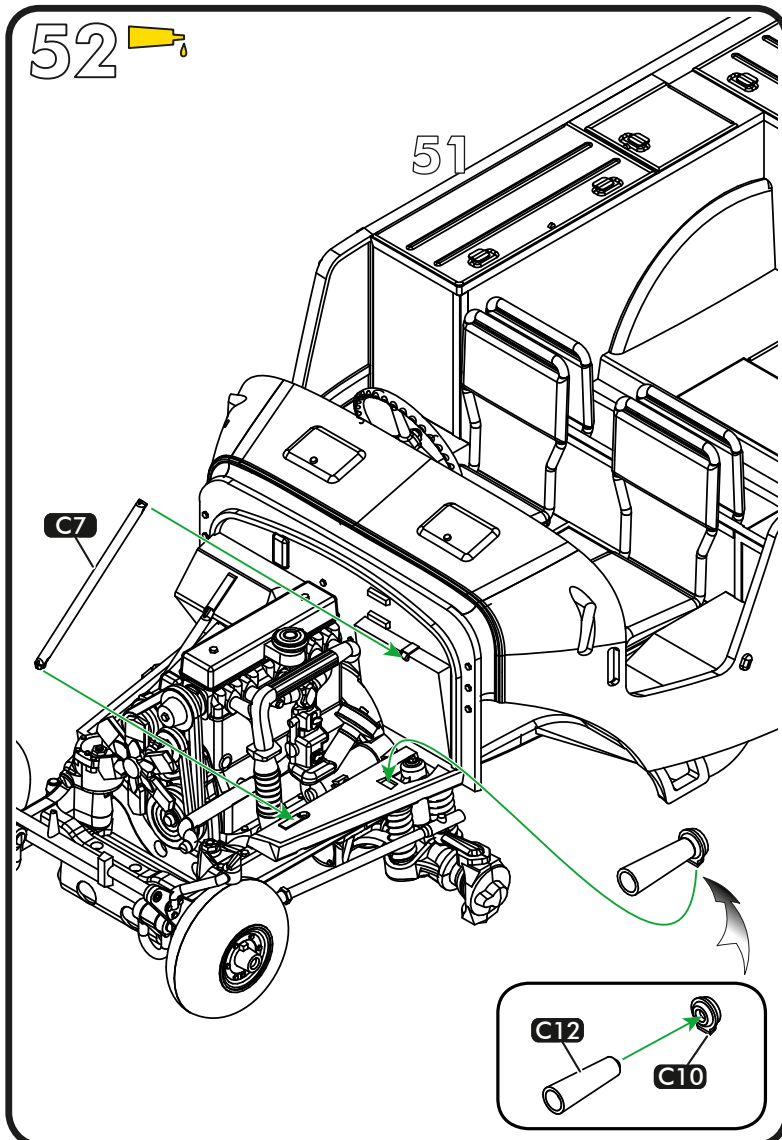
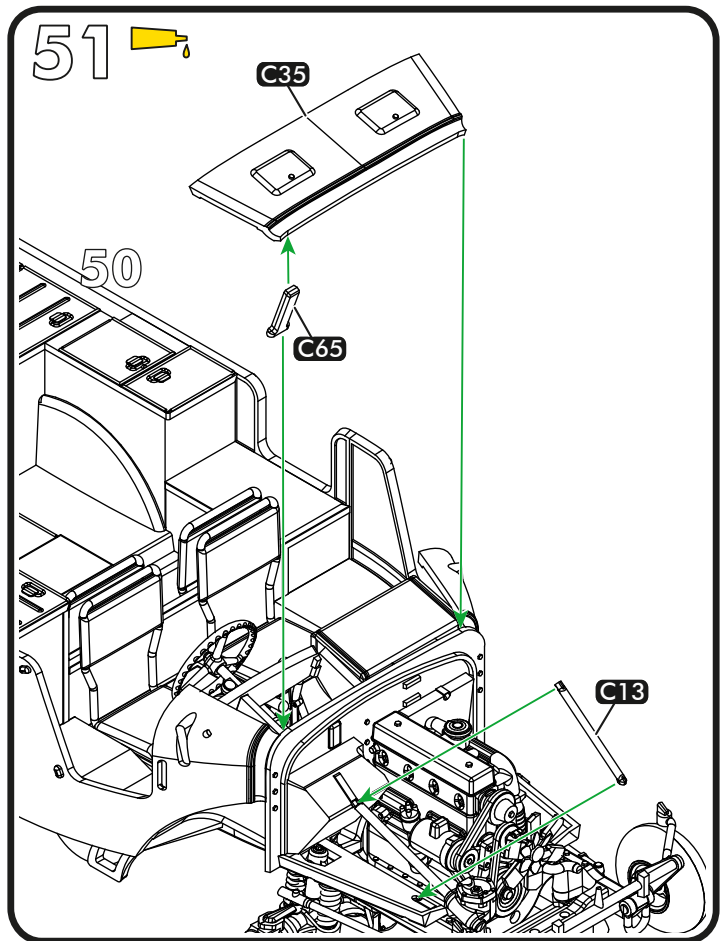
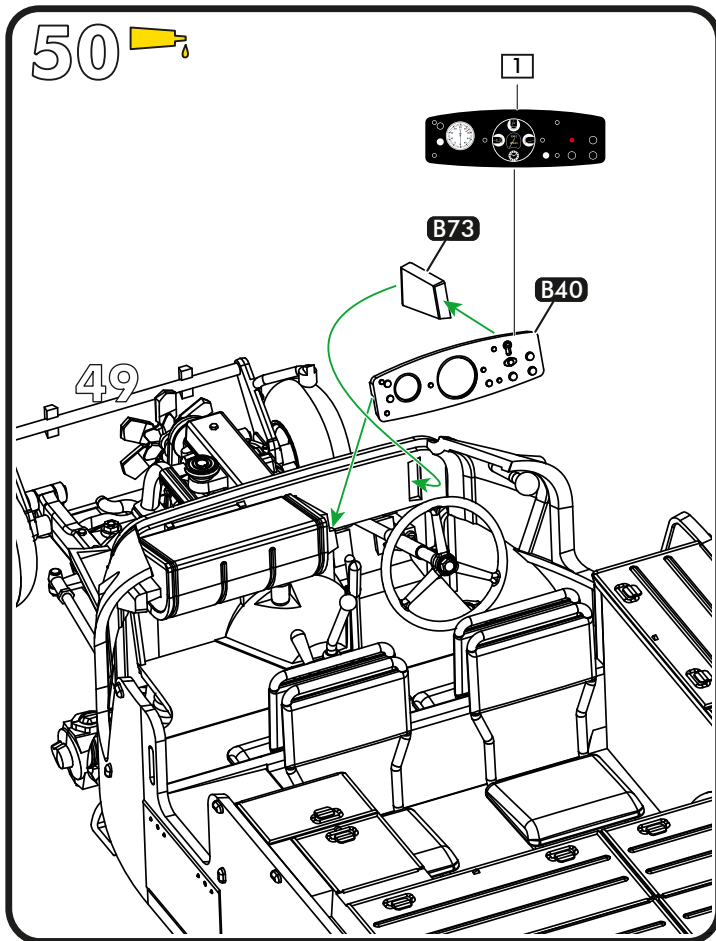

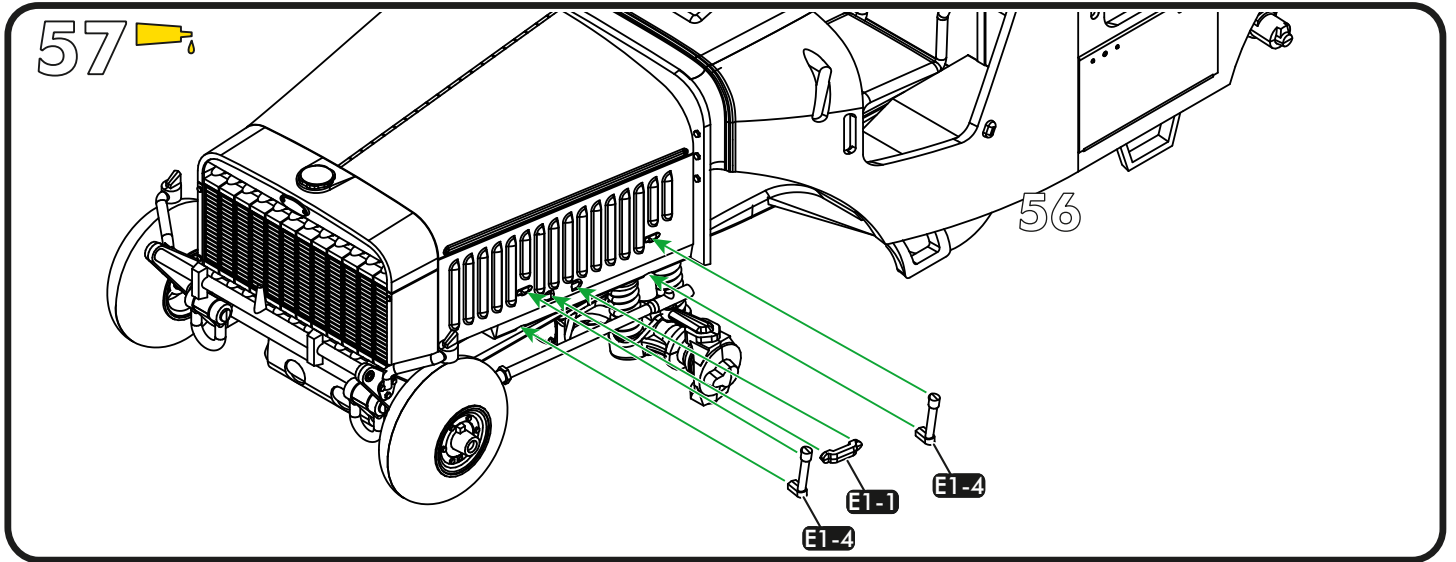
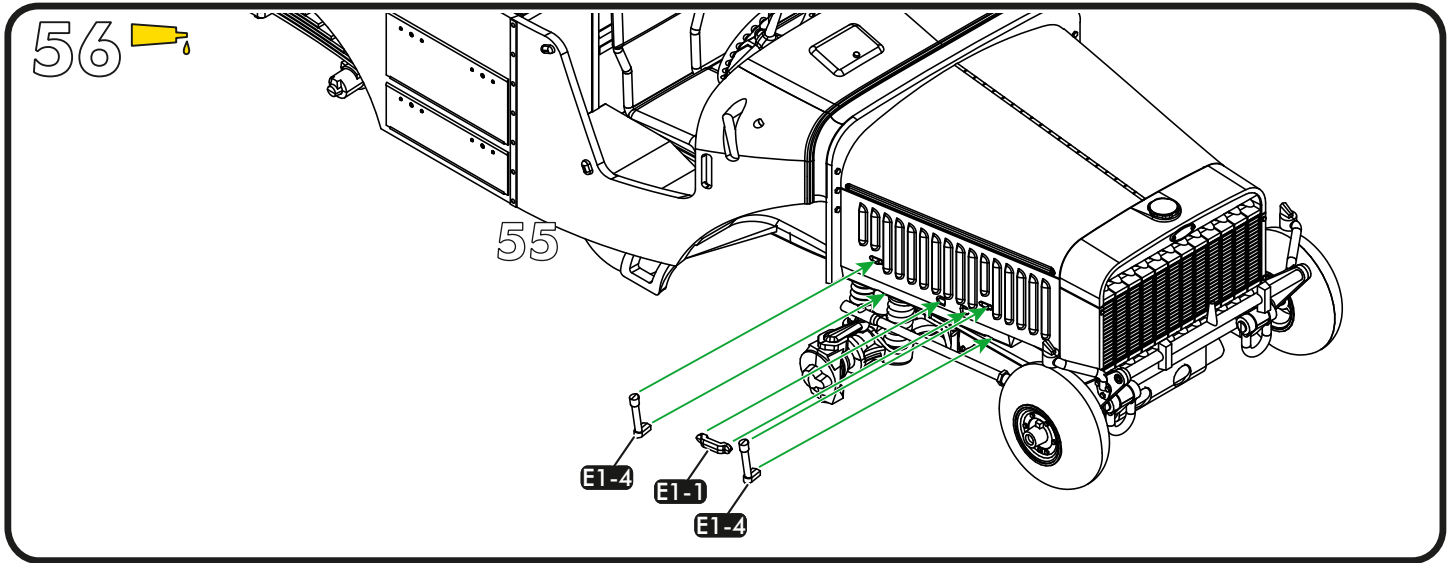
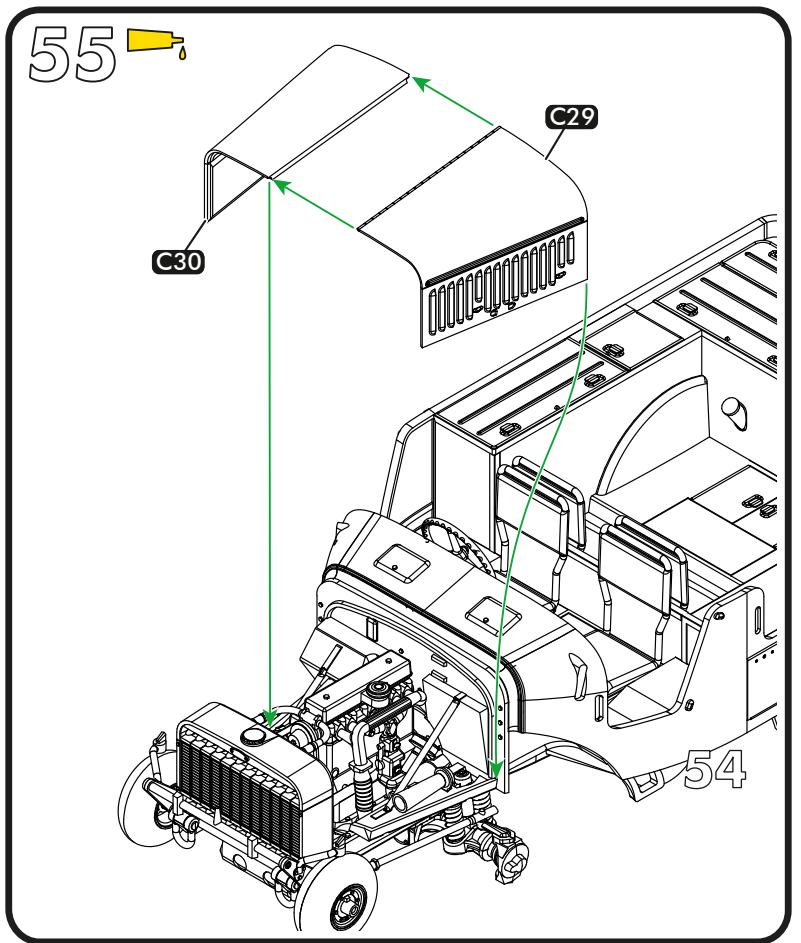
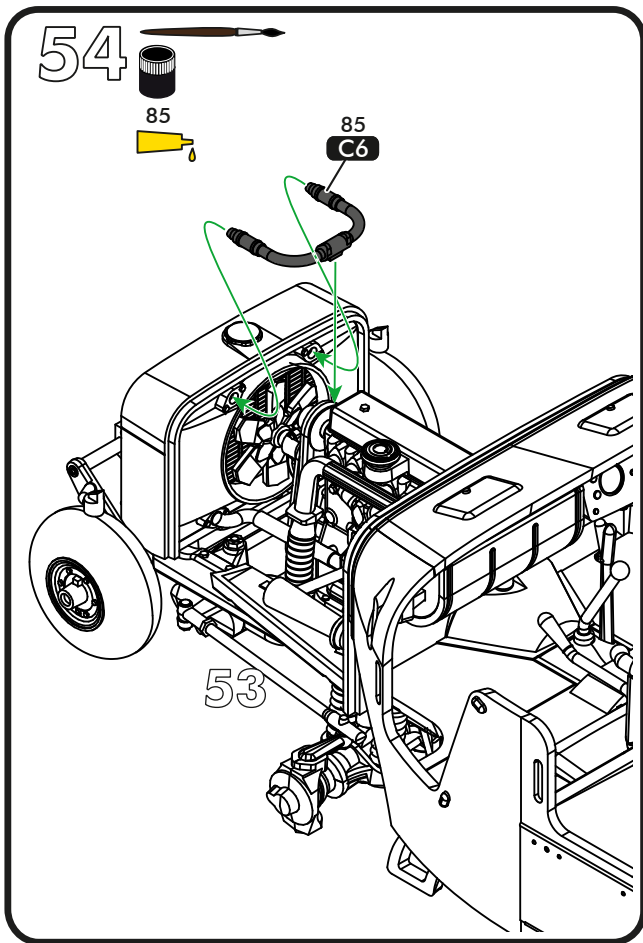

58

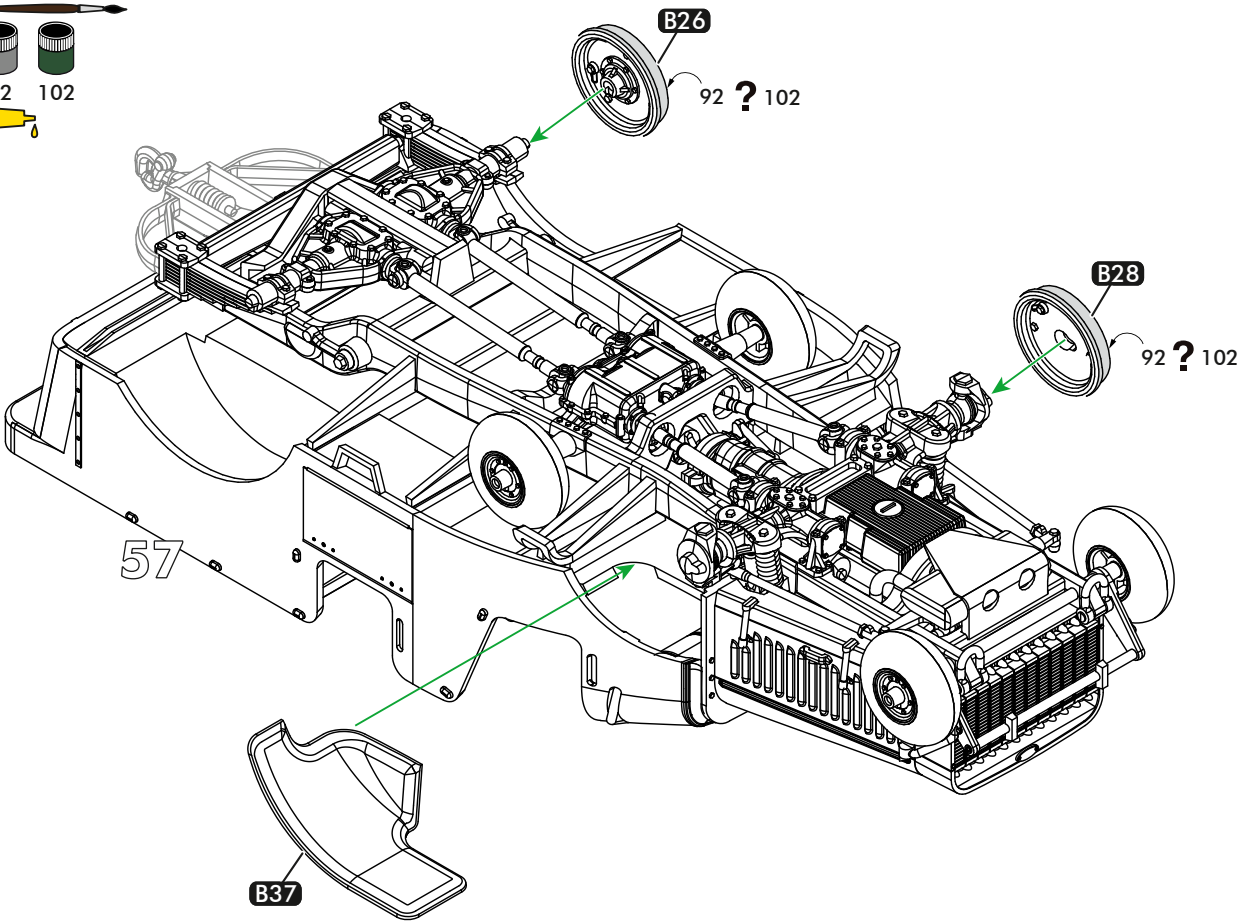
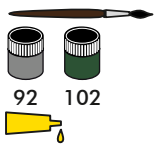

59

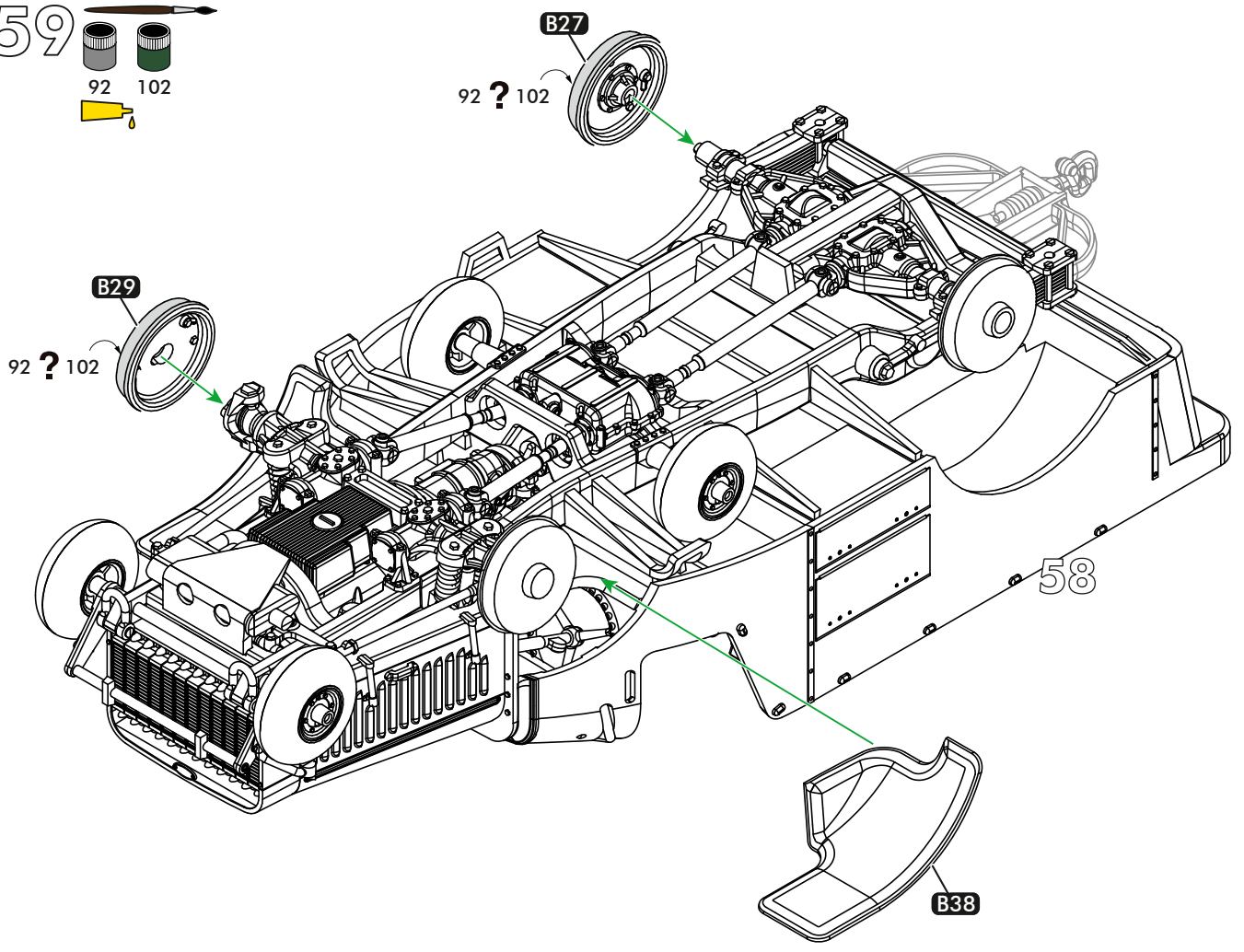
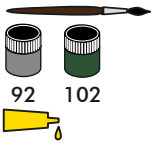

60

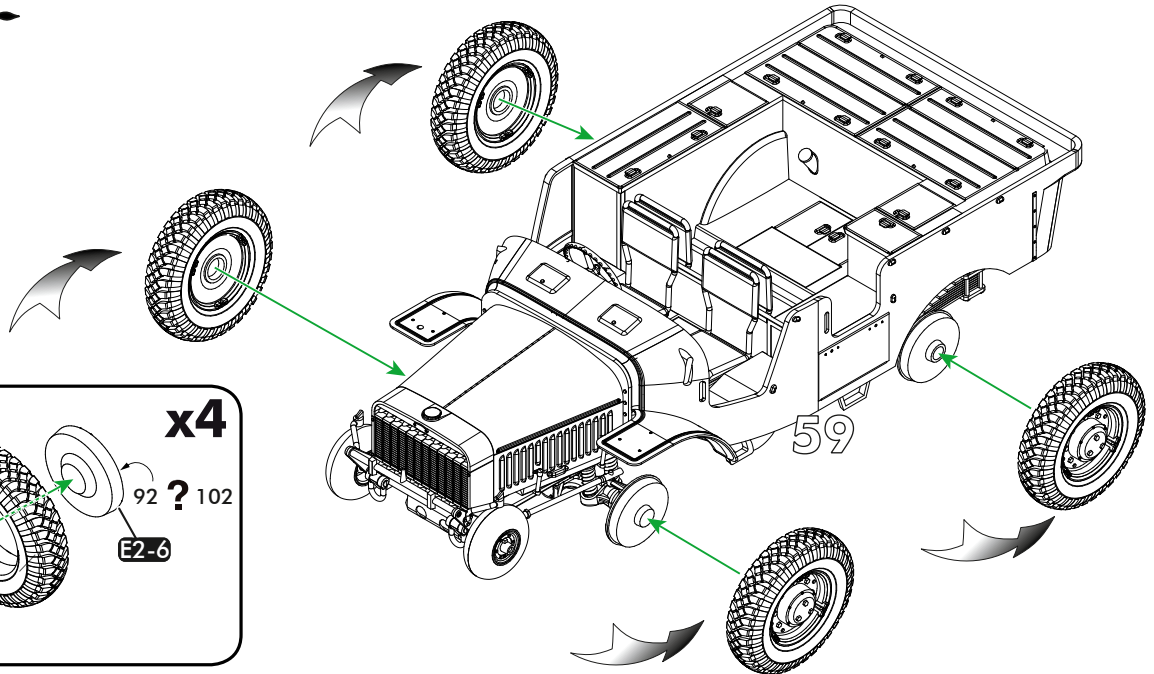
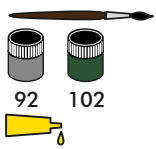

61

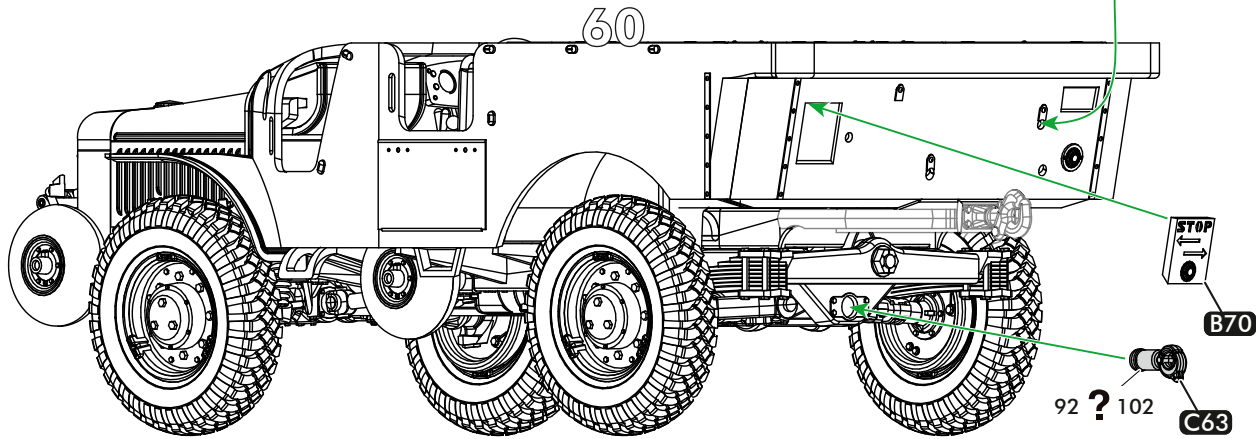
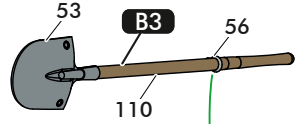
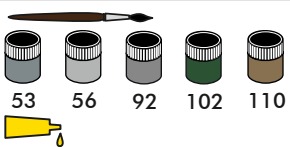

62

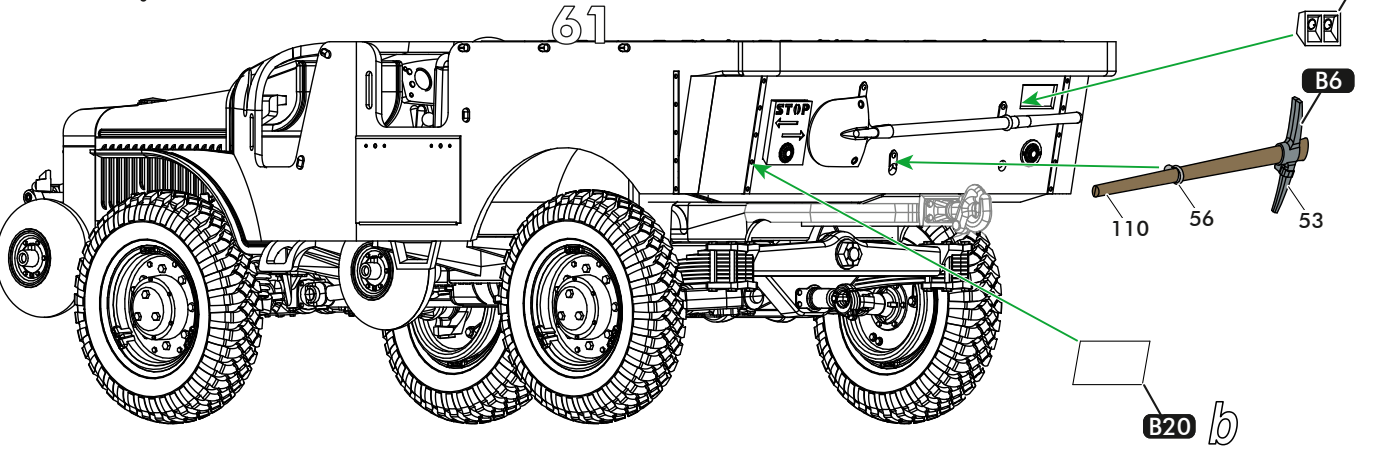
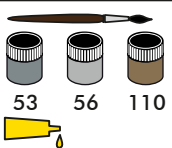

63

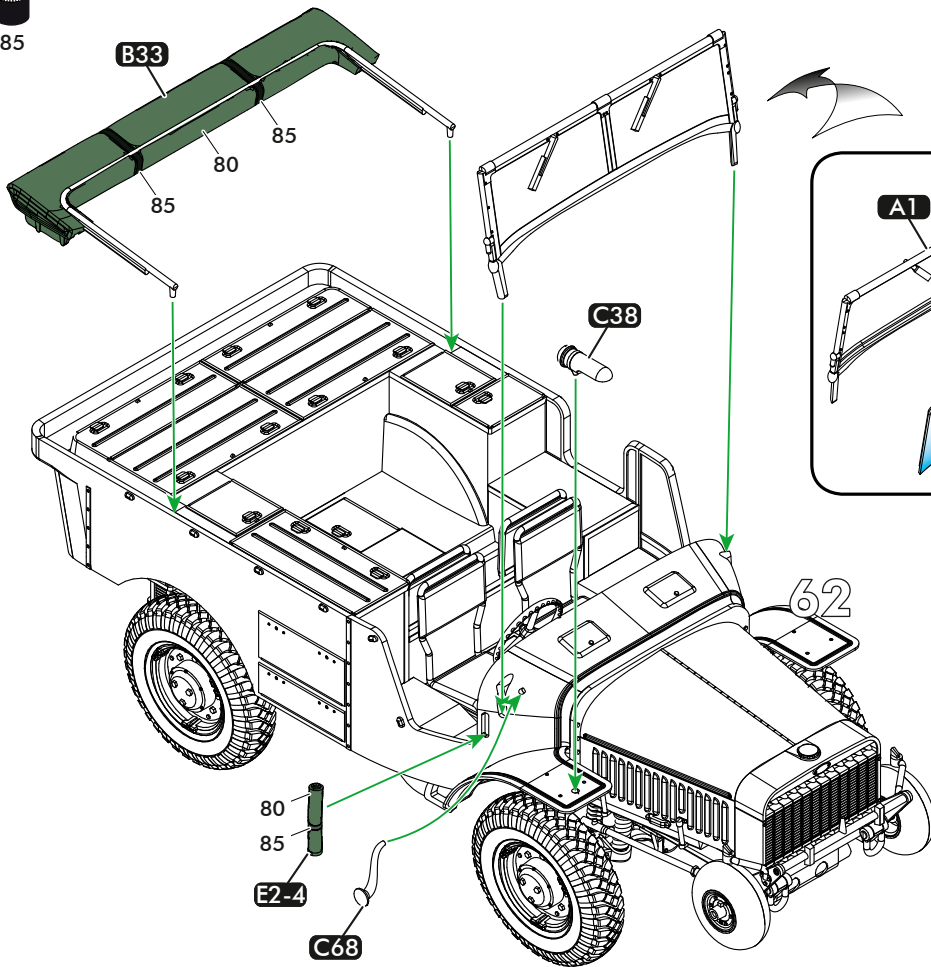
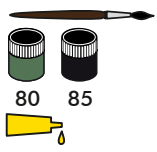

64

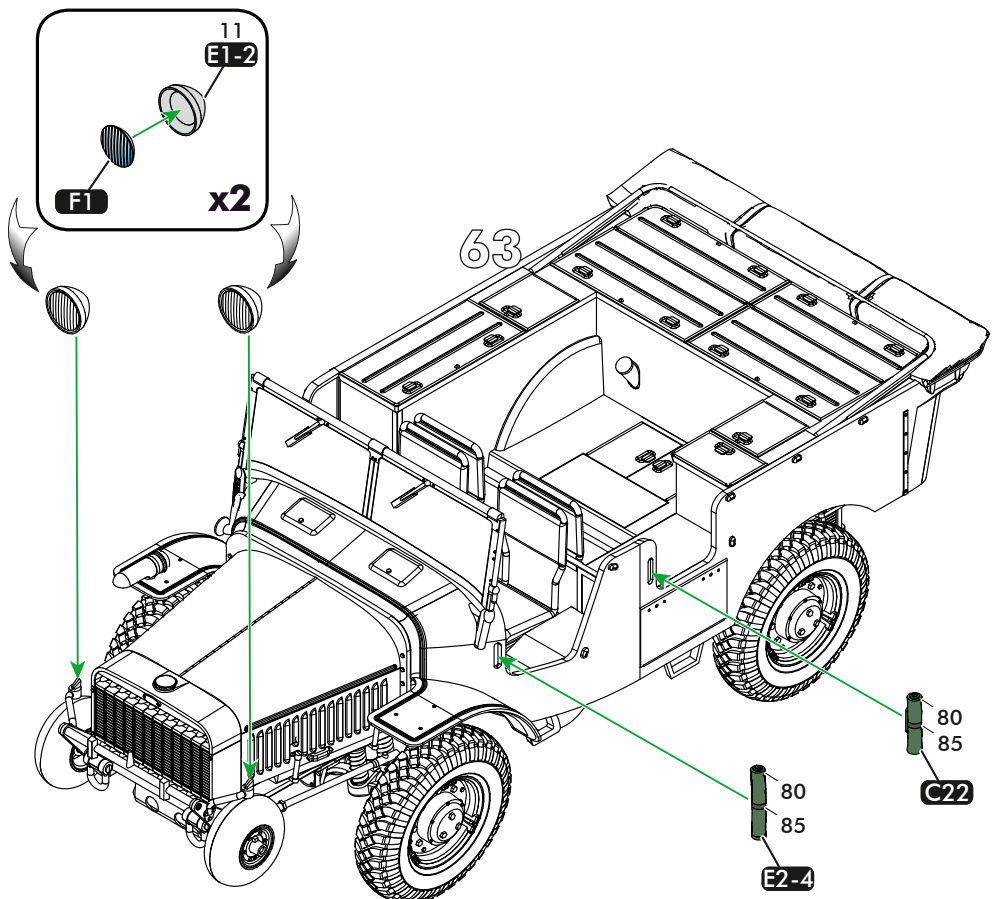
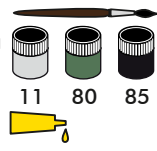

65

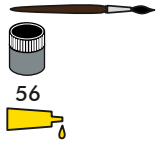

56

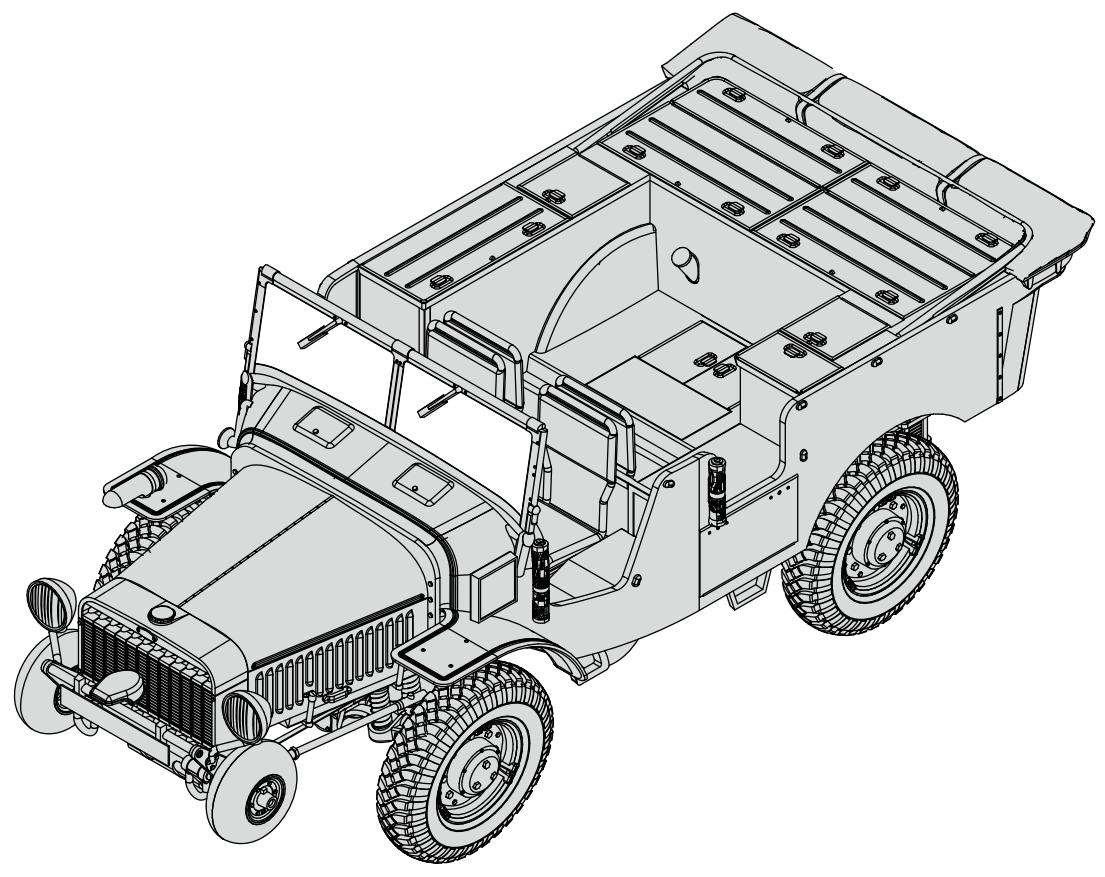
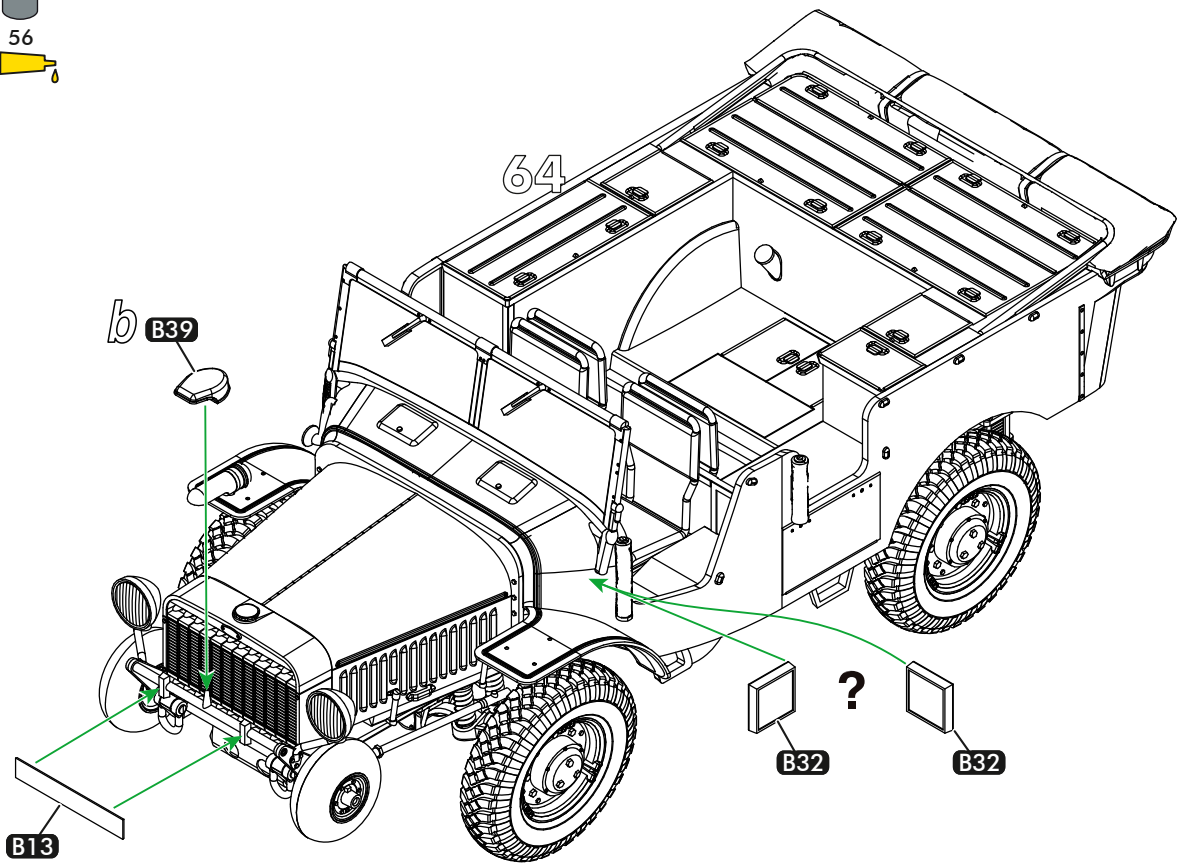

66

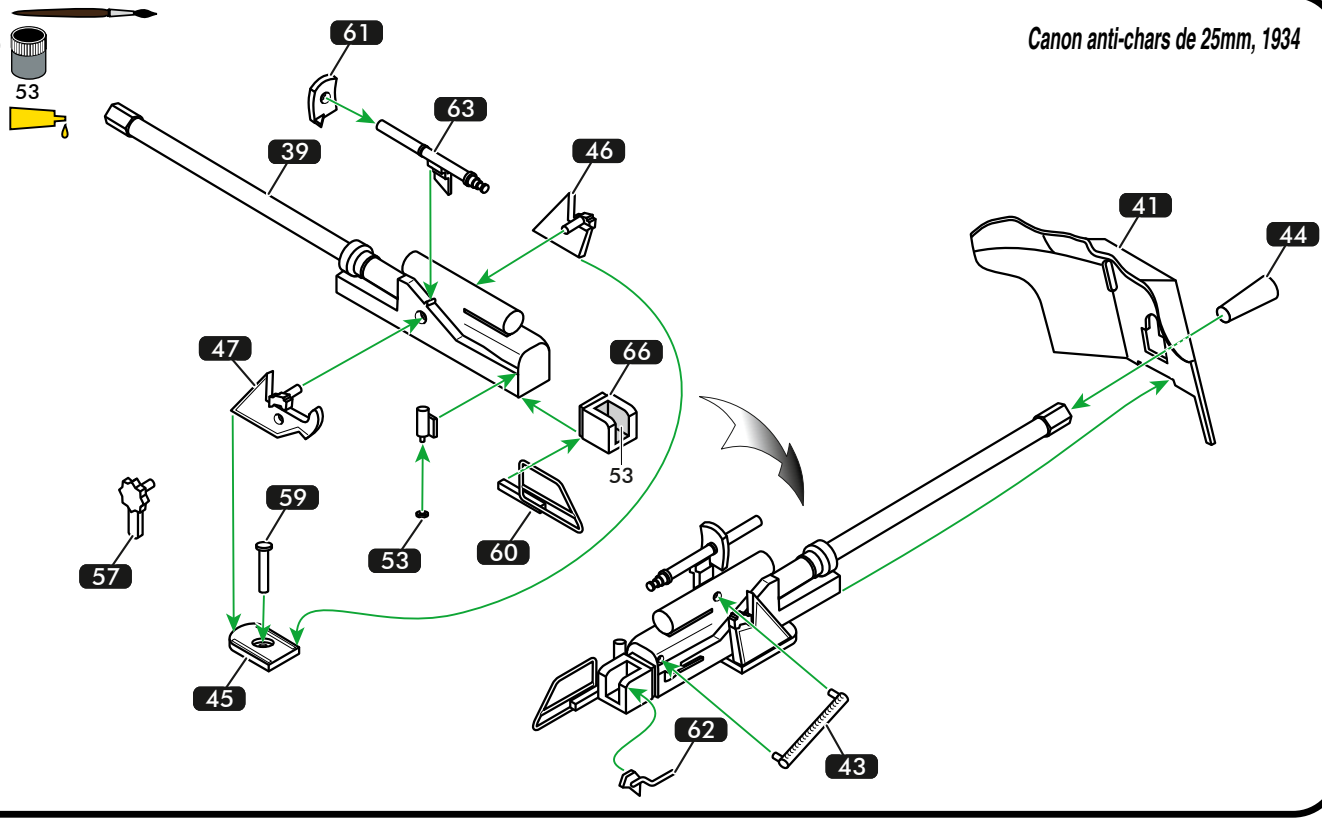

67

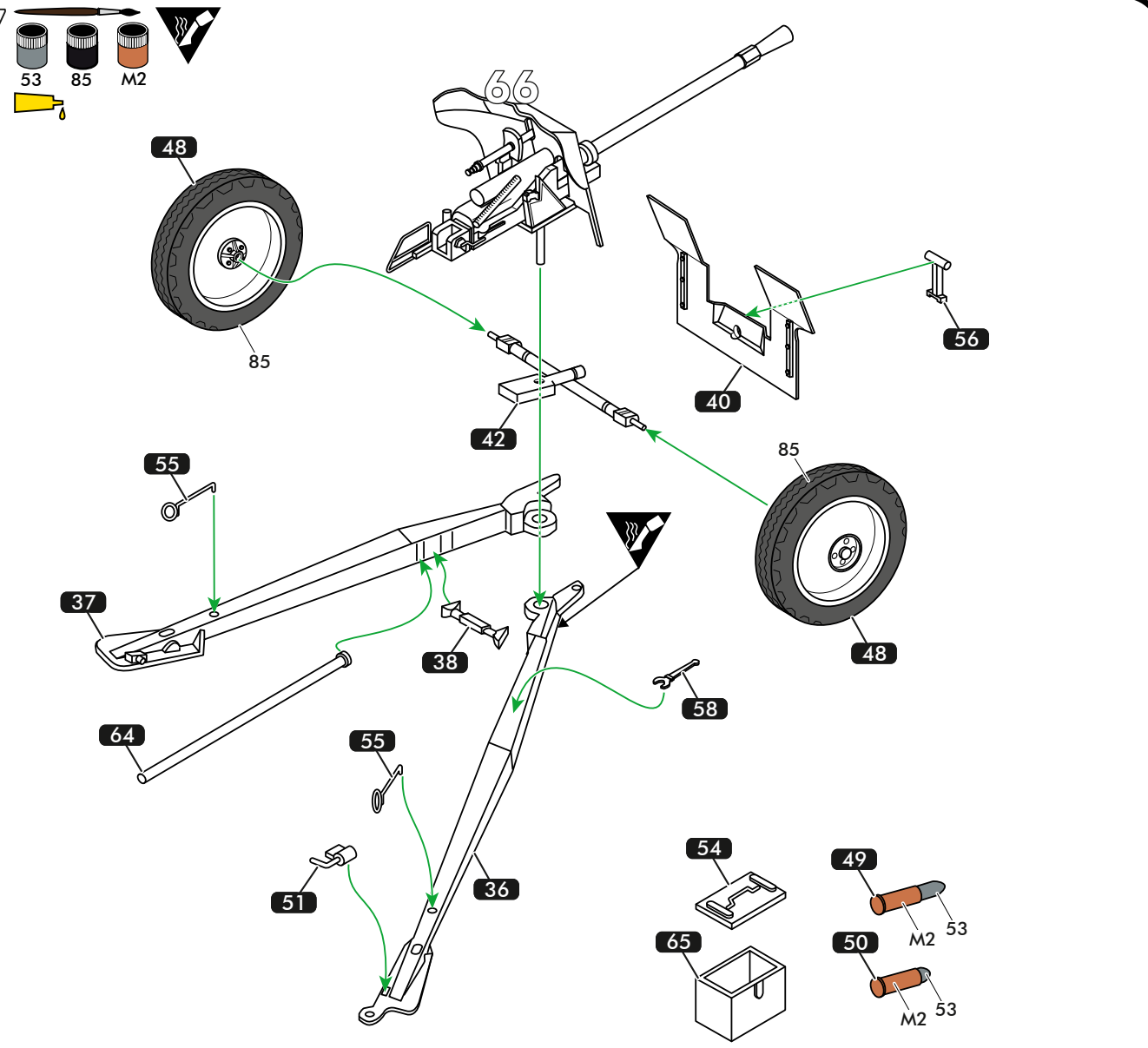

68

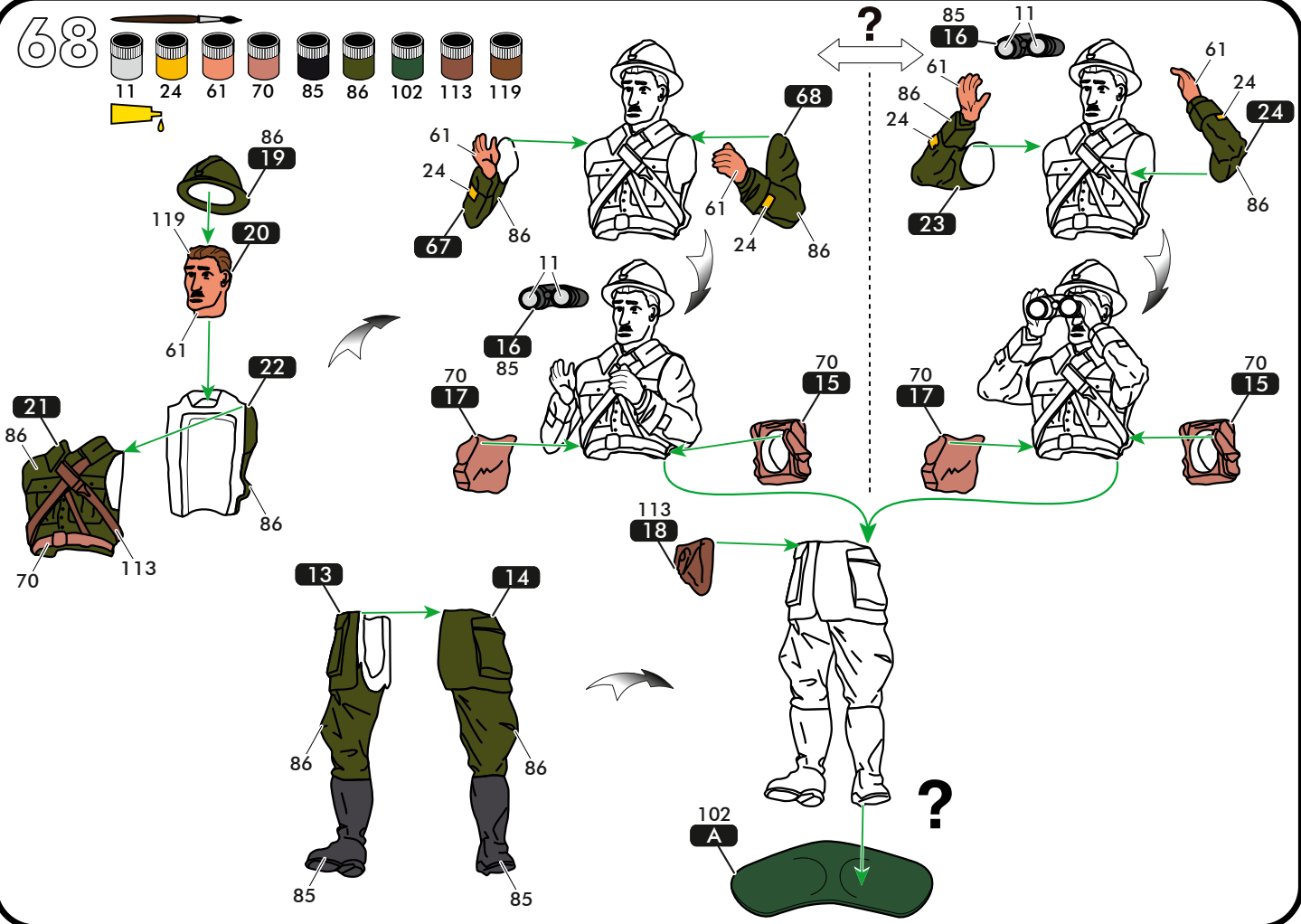
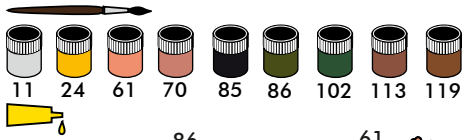

69

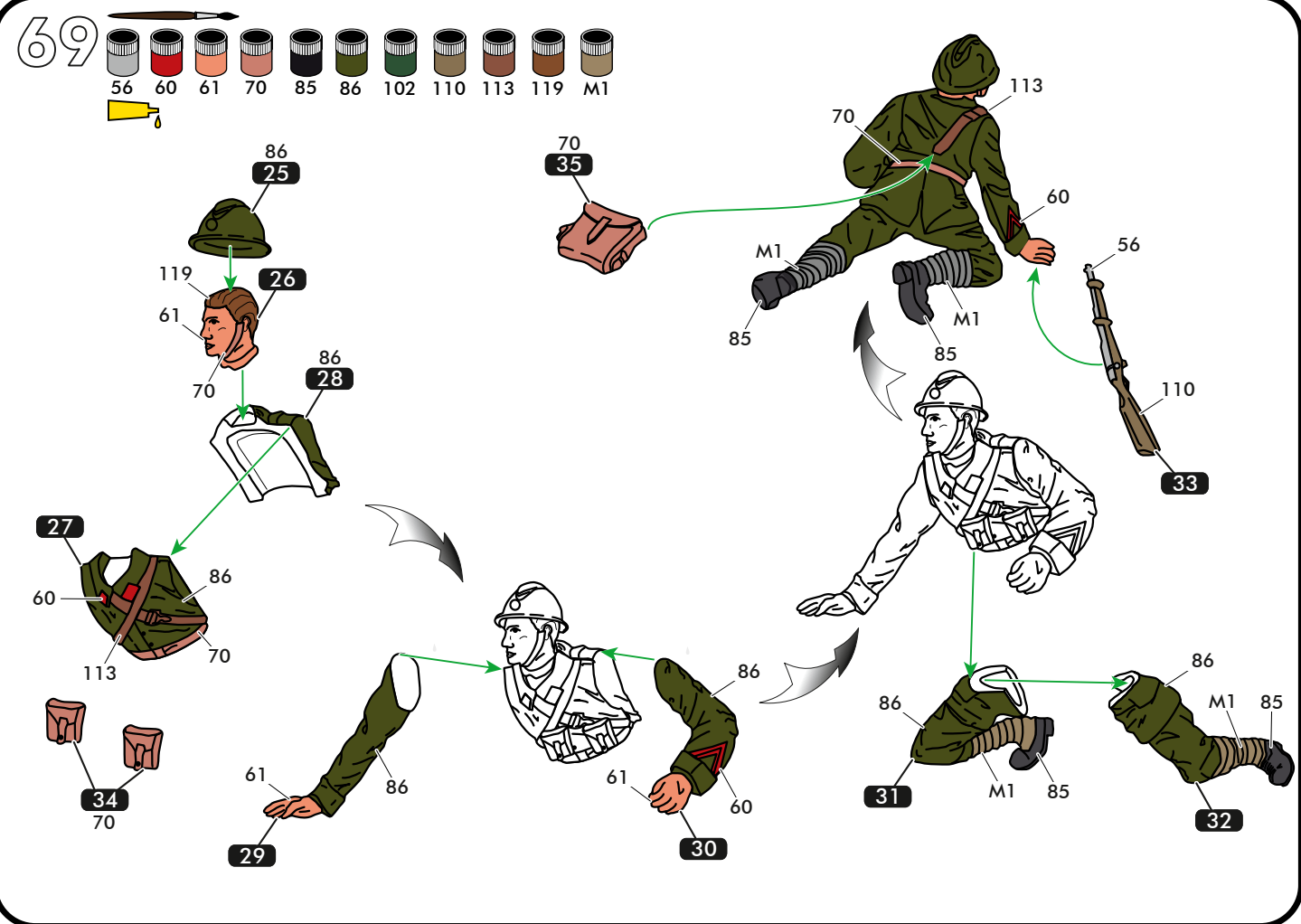
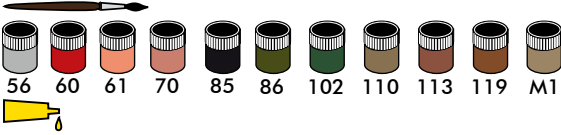

70

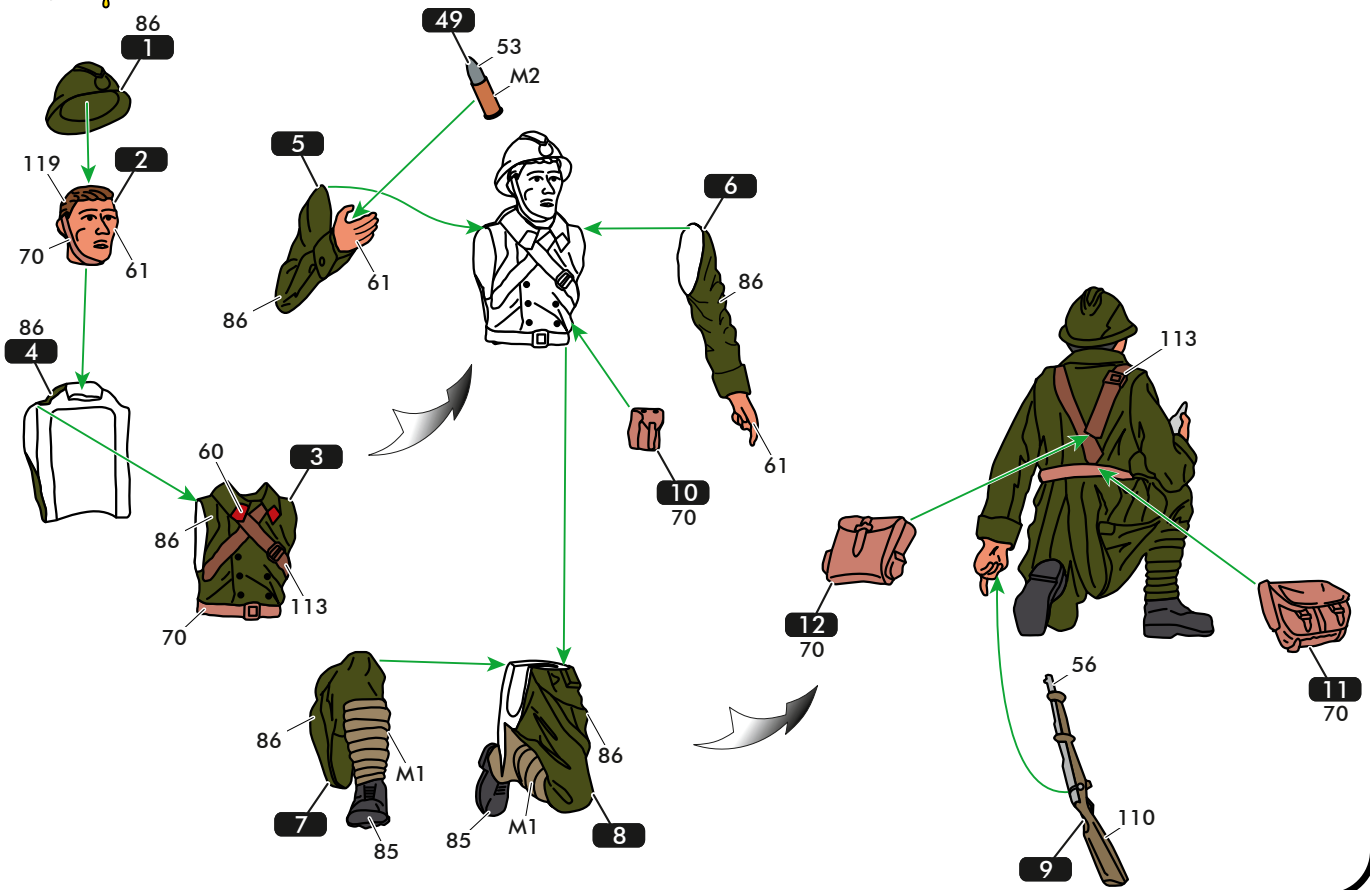
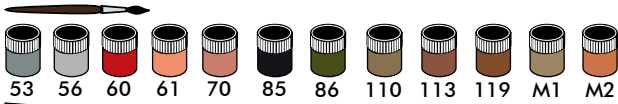

71

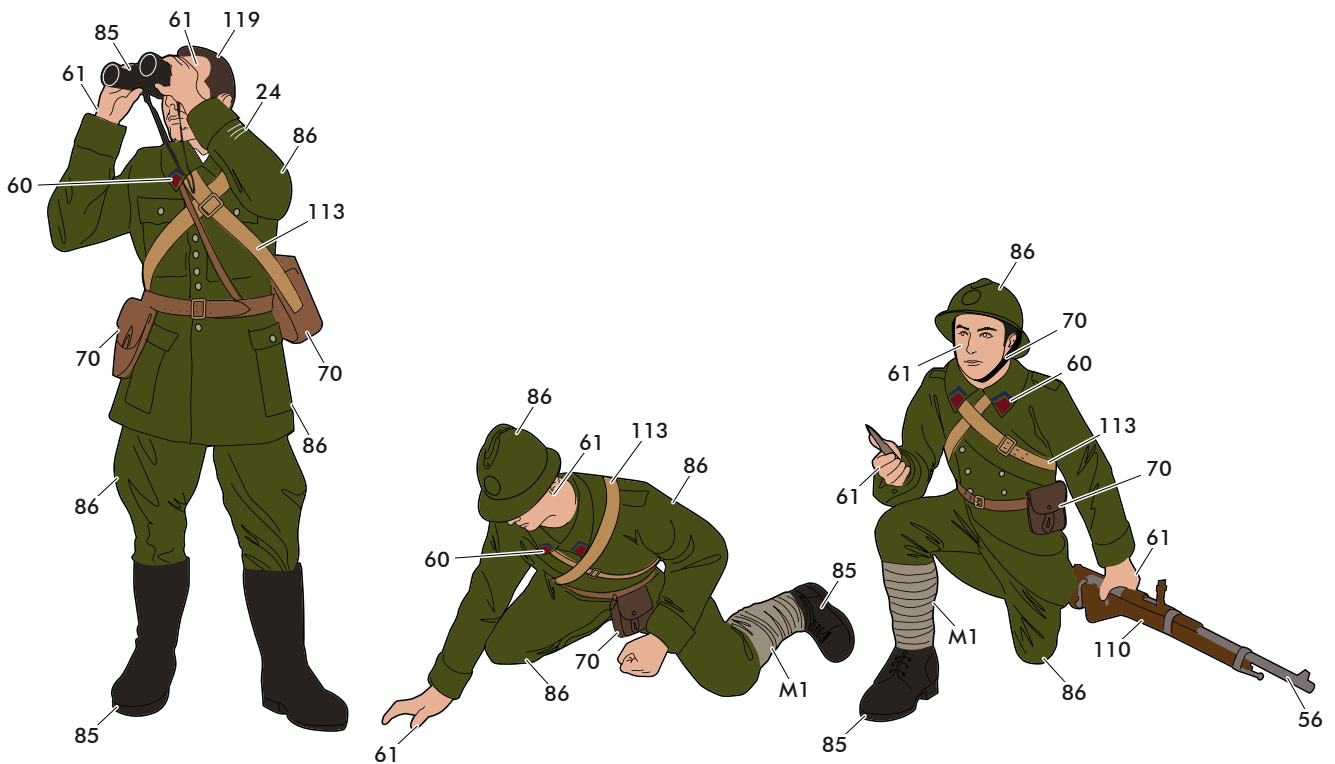
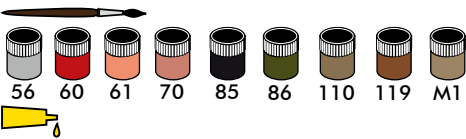

72

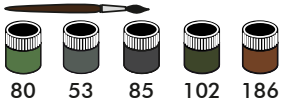

a 2^{ème} DLM Division Légère Mécanique, 13^{ème} Rgt de Dragons, 12^{ème} EDAC (Escadron Divisionnaire Anti Char)
 2nd DLM Division Légère Mécanique, 13th Rgt de Dragons, 12th EDAC (Divisional Anti-Tank Squadron)

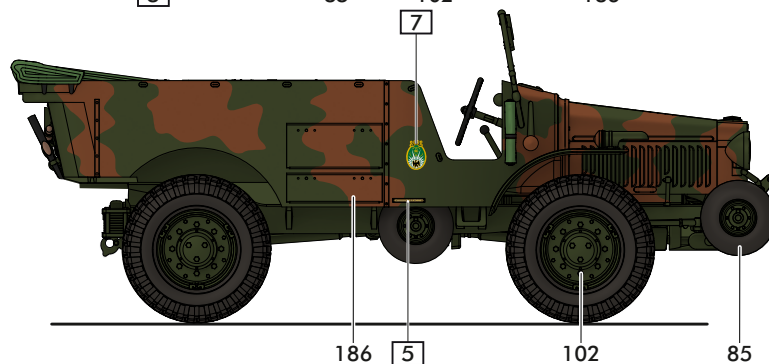
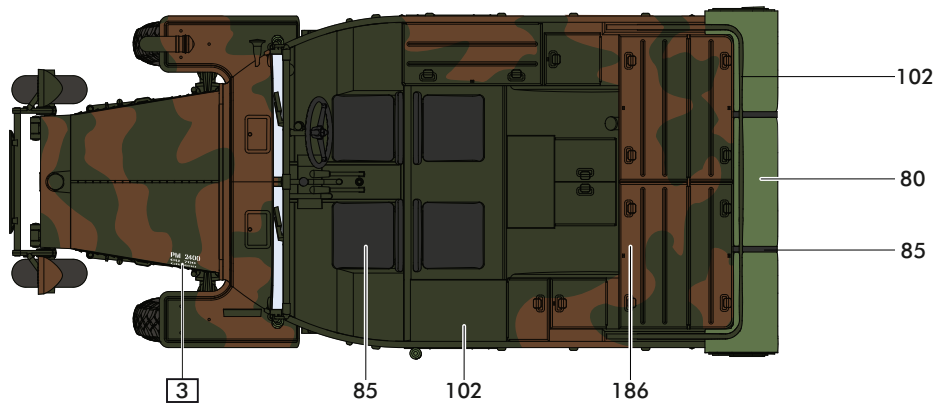
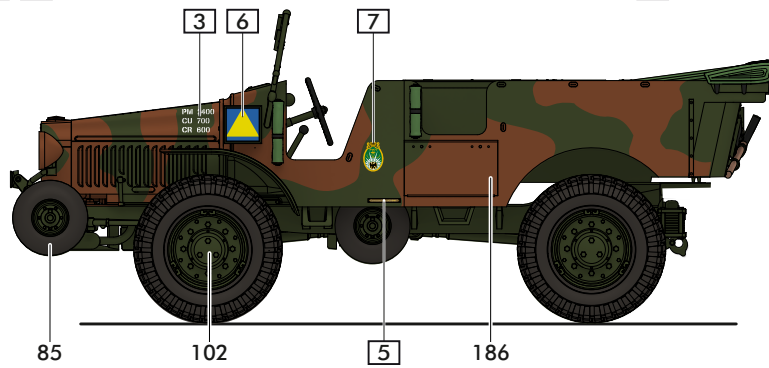
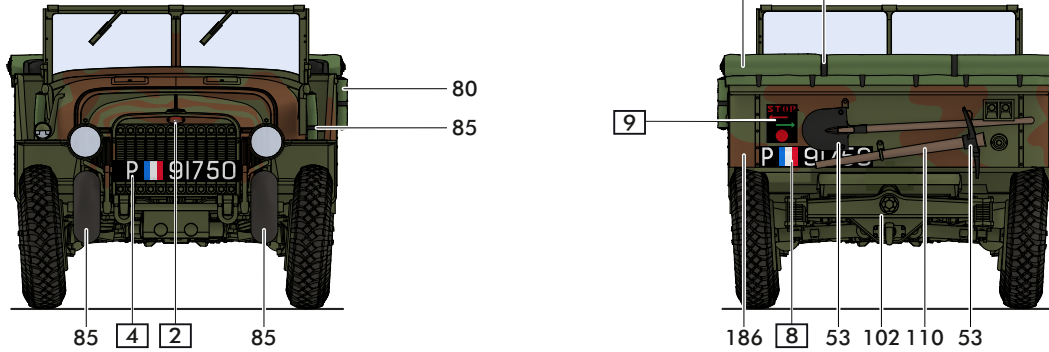
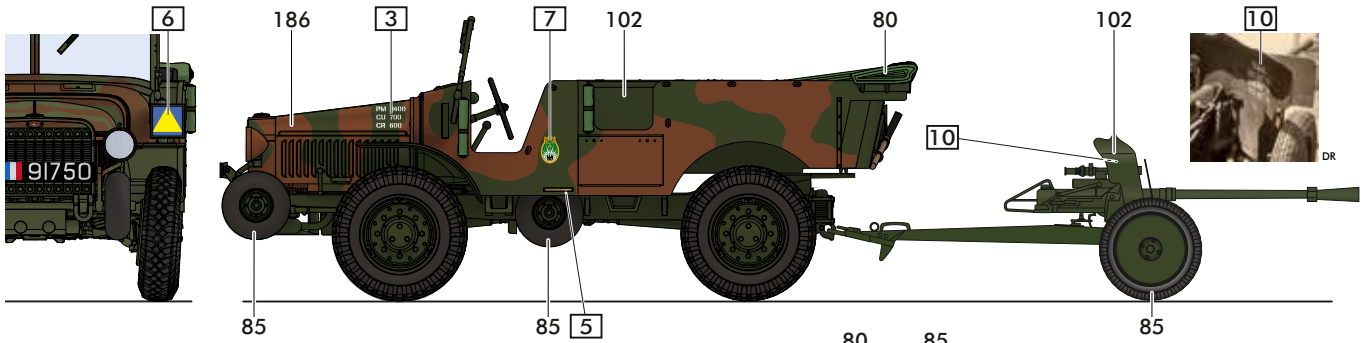

72

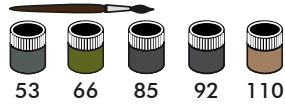

b Allemagne: LAFFLY (f) type V15T, 1941
 Germany: LAFFLY (f) V15T type, 1941

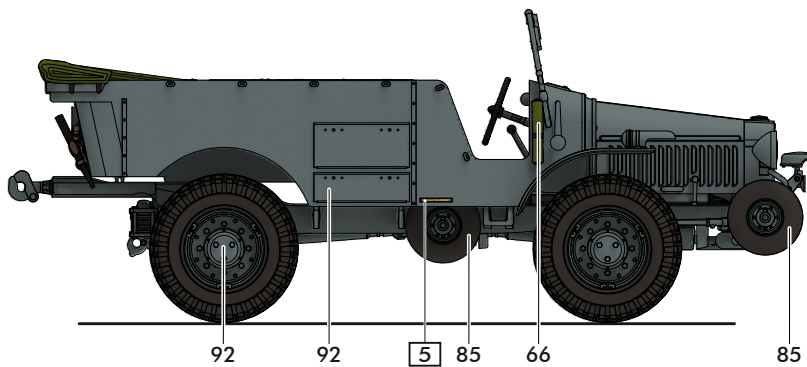
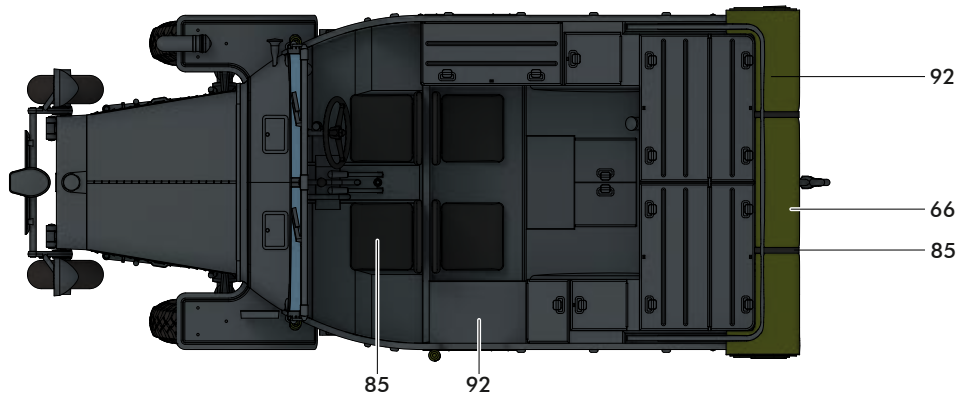
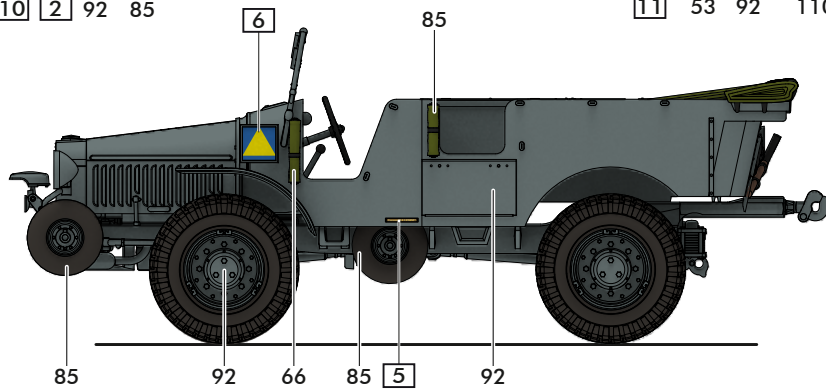
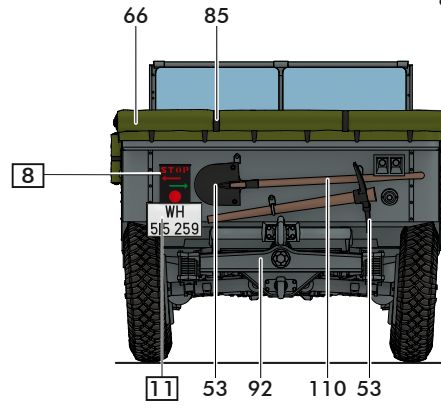
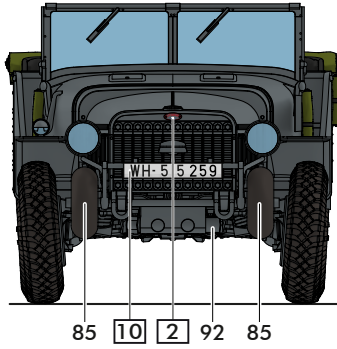
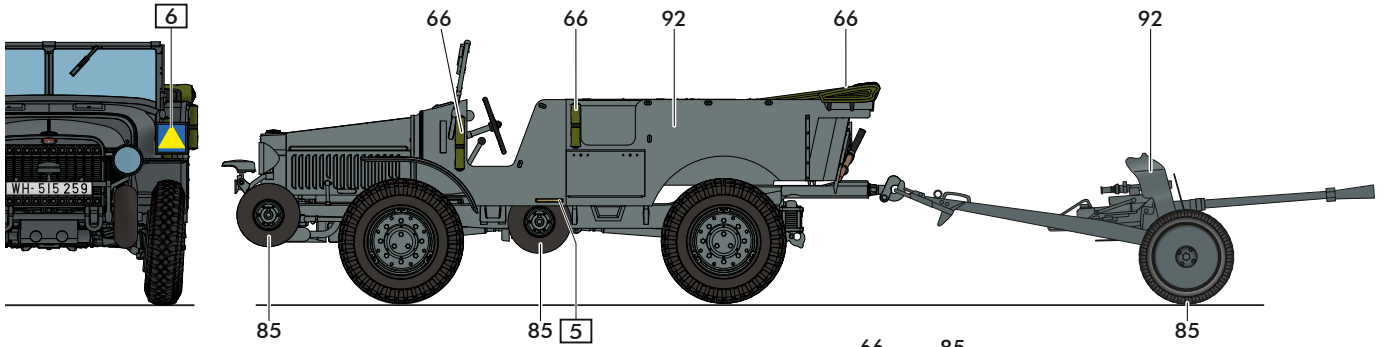

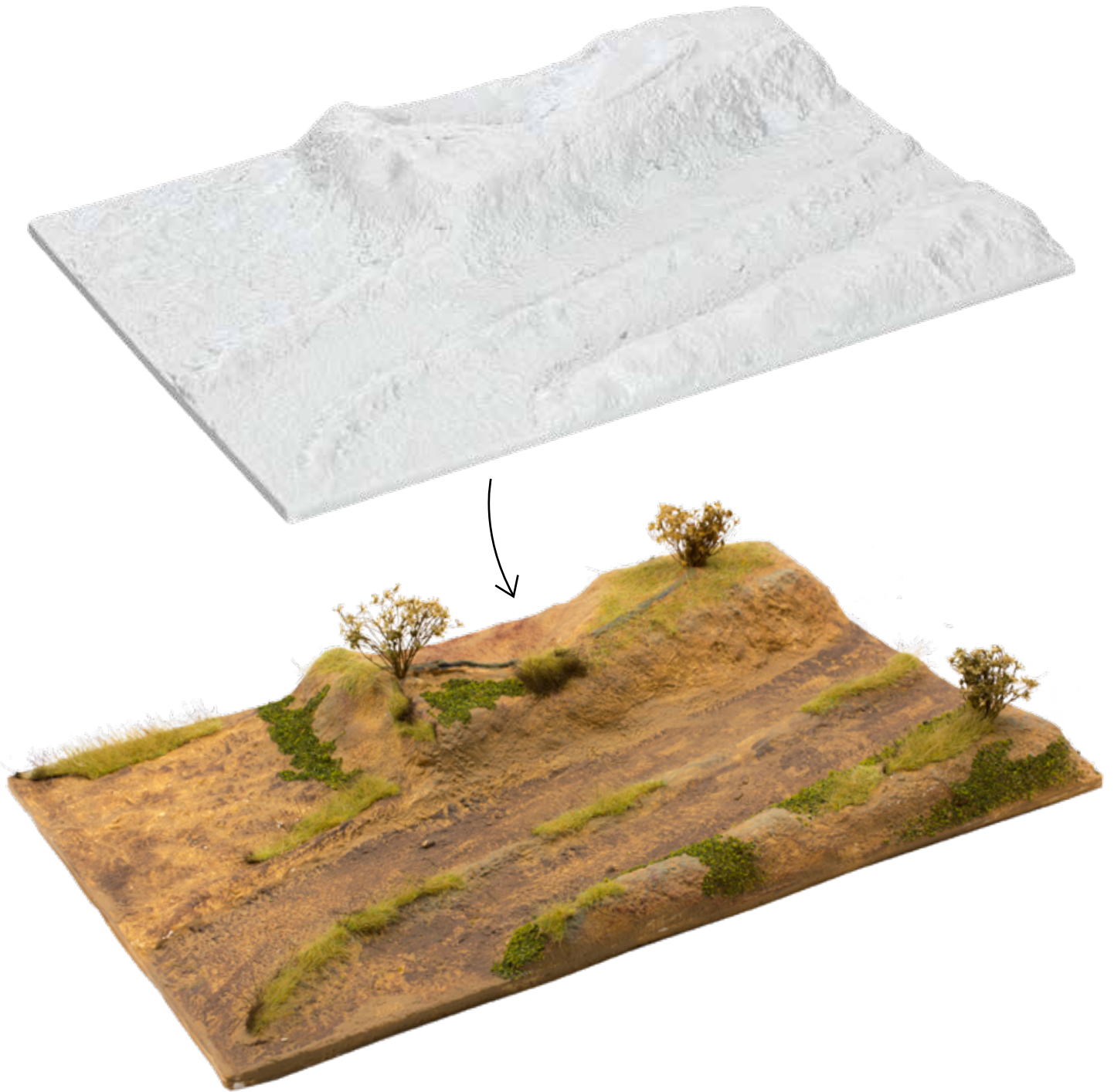

Français

Socle Diorama Campagne - Une fois peint et patiné, éventuellement enrichi d'éléments de décors disponibles chez votre détaillant, cet accessoire vous permettra d'obtenir avec un minimum de travail une scène de présentation idéale pour vos maquettes.

English

DIORAMA CAMPAGNE base - Once painted and patinated, possibly enriched with decor elements available at your retailer, this accessory will allow you to obtain with a minimum of work an ideal presentation scene for your models.

Deutsch

Diorama Landschaft - Bemalt und patiniert, möglicherweise mit Dekorelementen erweitert, die bei Ihrem Fachhändler erhältlich sind, können Sie mit diesem Zubehör und einem Minimum an Arbeit, eine ideale Präsentationsszenerie für Ihre Modelle gestalten.

Español

Diorama de paisaje - Una vez pintado y patinado, y enriquecido opcionalmente con elementos decorativos disponibles en su distribuidor, con estos accesorios y un mínimo de trabajo puede crear un escenario de presentación ideal para sus modelos.

Italiano

Plastico paesaggio - Dipinto e patinato, eventualmente arricchito con elementi decorativi disponibili presso il tuo rivenditore, questo accessorio, con un minimo di lavoro, ti permette di creare un'ambientazione ideale per i tuoi modelli.

Nederlands

Diorama natuurlandschap - Wanneer dit accessoire eenmaal geverfd en gepatineerd is en eventueel verrijkt met decoratieve elementen die verkrijgbaar zijn bij uw winkelier, kunt u met een minimum aan werk zorgen voor een ideale presentatiescène voor uw modellen.

VISITEZ-NOUS EN LIGNE !

VISIT US DIGITALLY!
BESUCHEN SIE UNS DIGITAL!

 www.heller.fr

 [instagram.com/heller.fr](https://www.instagram.com/heller.fr)

 [facebook.com/heller.fr](https://www.facebook.com/heller.fr)

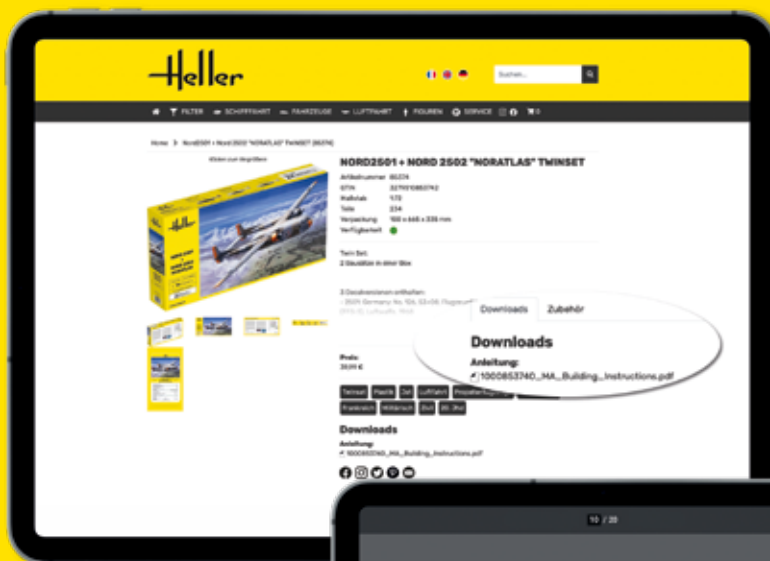

Choisissez l'article désiré et téléchargez la notice de montage.
Choose your desired article and download the instructions.
Wählen Sie den gewünschten Artikel und laden Sie die Anleitung herunter.

**Download all
instructions!**

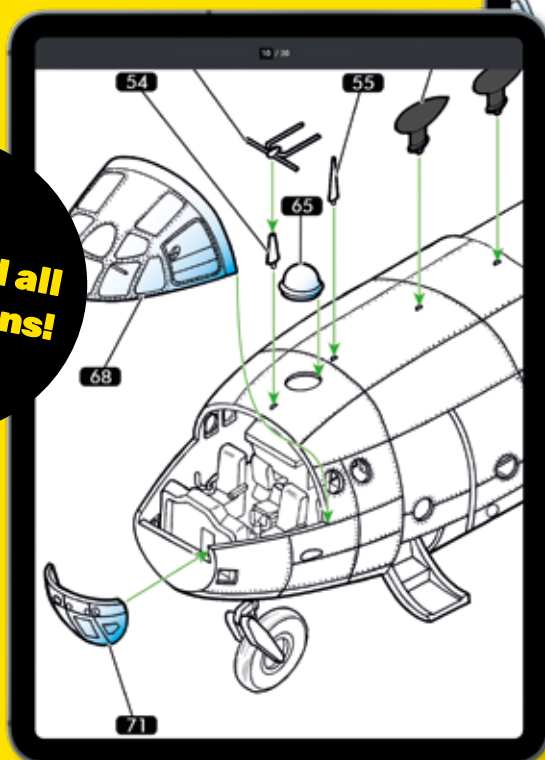

Grossissement des instructions pour
une vue détaillée.

Enlarge the instructions for a more
detailed view.

Vergrößern Sie die Anleitung für eine
detailliertere Ansicht.

Service consommateurs
Pour toute demande de SAV, connectez-vous
sur notre site www.heller.fr.

Customer Service
For after-sales service requests,
please contact us through our website
www.heller.fr.

Endverbraucherservice
Bitte besuchen Sie uns auf www.heller.fr
für alle Ersatzteilanfragen.

Heller Hobby GmbH

Erlenbacher Str. 3 • 42477 Radevormwald • GERMANY

 +49 (0) 2195-92773-0  info@heller.fr