

Heller

F-104G STARFIGHTER

30520



VISITEZ-NOUS SUR LES RÉSEAUX SOCIAUX

VISIT US ON SOCIAL MEDIA!
BESUCHEN SIE UNS AUF SOCIAL MEDIA!

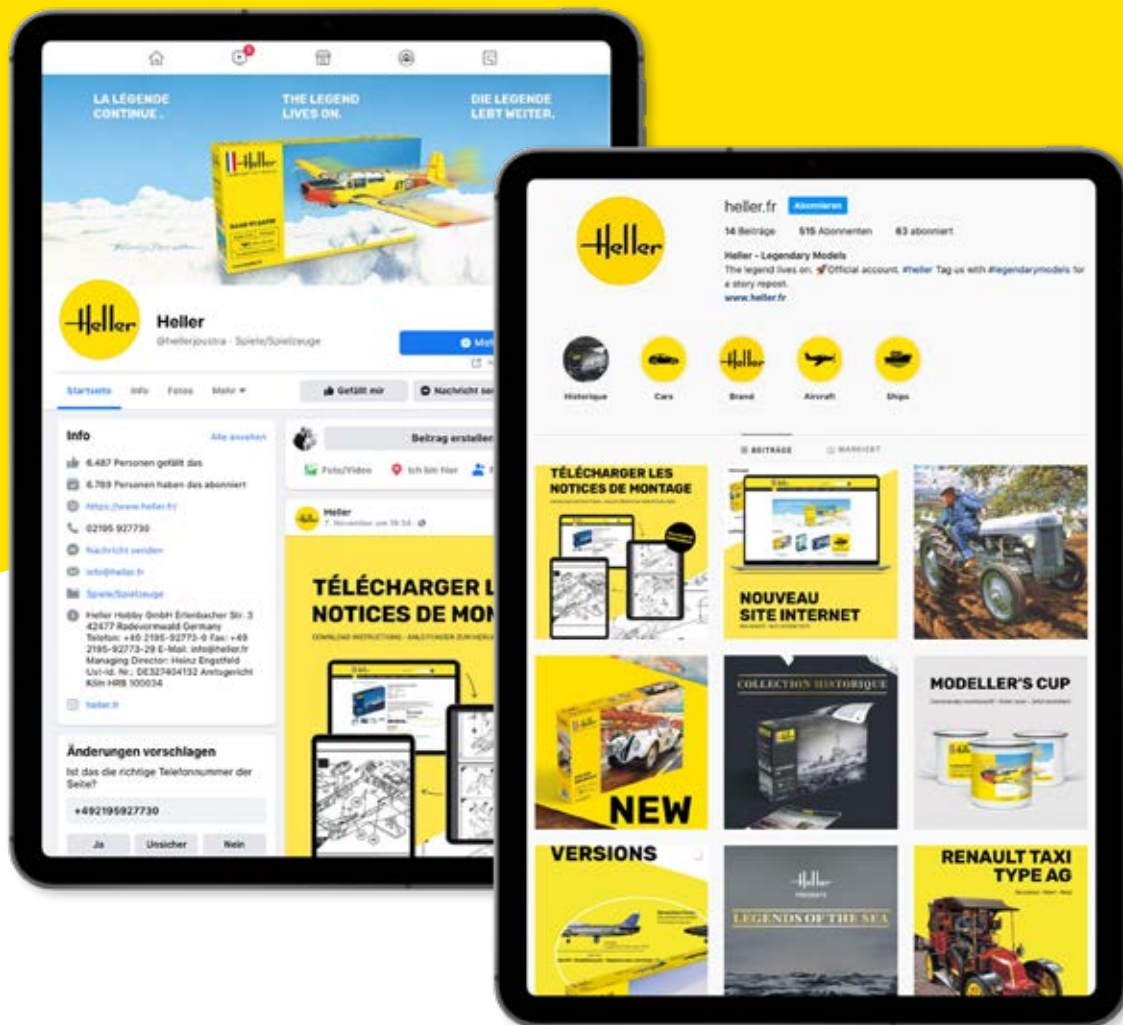

@instagram.com/heller.fr • facebook.com/heller.fr

Français

À la suite des opérations menées pendant la guerre de Corée, Lockheed a développé le chasseur léger de supériorité aérienne, F-104 Starfighter, pour l'USAF. Il a été optimisé pour atteindre des vitesses et des performances ascensionnelles élevées. Le premier vol de ce type d'avion a eu lieu le 4 mars 1954. En 1958, un F-104A atteint 2 259,538 km/h, établissant ainsi un record de vitesse.

Deutsch

Als Konsequenz aus den Einsätzen im Korea-Krieg wurde bei Lockheed für die USAF der leichte Luftüberlegenheitsjäger F-104 Starfighter entwickelt. Optimiert war er für hohe Geschwindigkeiten und Steigleistung. Der Erstflug dieses Flugzeugtyps war am 04. März 1954. 1958 erreichte eine F-104A die 2259,538 km/h und erzielte einen Geschwindigkeitsrekord.

Italiano

Come conseguenza delle missioni nella guerra di Corea, Lockheed sviluppò il caccia leggero da superiorità aerea F-104 Starfighter per l'USAF. Era ottimizzato per alte velocità e potenza di salita. Il primo volo di questo tipo di aereo avvenne il 4 marzo 1954. Nel 1958, un F-104A raggiunse i 2259,538 km/ora e stabilì un record di velocità.

English

As a consequence of the Korean War, Lockheed developed the F-104 Starfighter light air superiority fighter for the USAF. It was optimised for high speeds and climb performance. The first flight of this aircraft type was on 04 March 1954. In 1958, an F-104A reached 2259.538 km/h and set a speed record.

Español

A raíz de las misiones durante la Guerra de Corea, Lockheed desarrolló el caza ligero de superioridad aérea F-104 Starfighter para la USAF. Se optimizó para altas velocidades y potencia de ascenso. El primer vuelo de este tipo de aviones fue el 4 de marzo de 1954. En 1958, un F-104A alcanzó los 2259,538 km/h y estableció un récord de velocidad.

Nederlands

Als gevolg van de operaties in de Koreaanse Oorlog, werd het lichte jachtvliegtuig F-104 Starfighter ontwikkeld bij Lockheed voor de USAF. Het vliegtuig is geoptimaliseerd voor hoge snelheden en klimvermogen. De eerste vlucht van dit type vliegtuig was op 4 maart 1954. In 1958 bereikte een F-104A 2259,538 km/u en vestigde daarmee een snelheidsrecord.

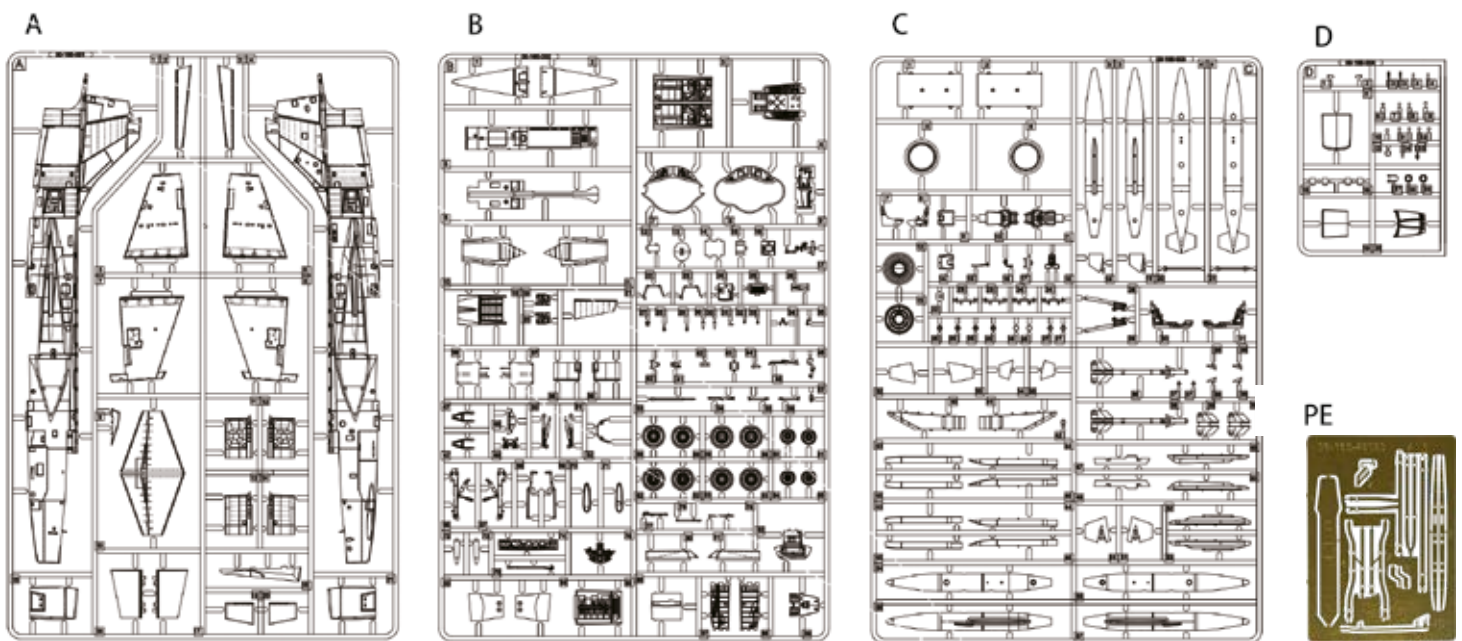

Accessoires | Accessories | Zubehör

Tube de pitot en métal, Drapeau, Pièces photodécoupées
Metal pitot tube, Flag, Photo-etched parts
Pitotrohr aus Metall, Fahne, Fotoätzteile

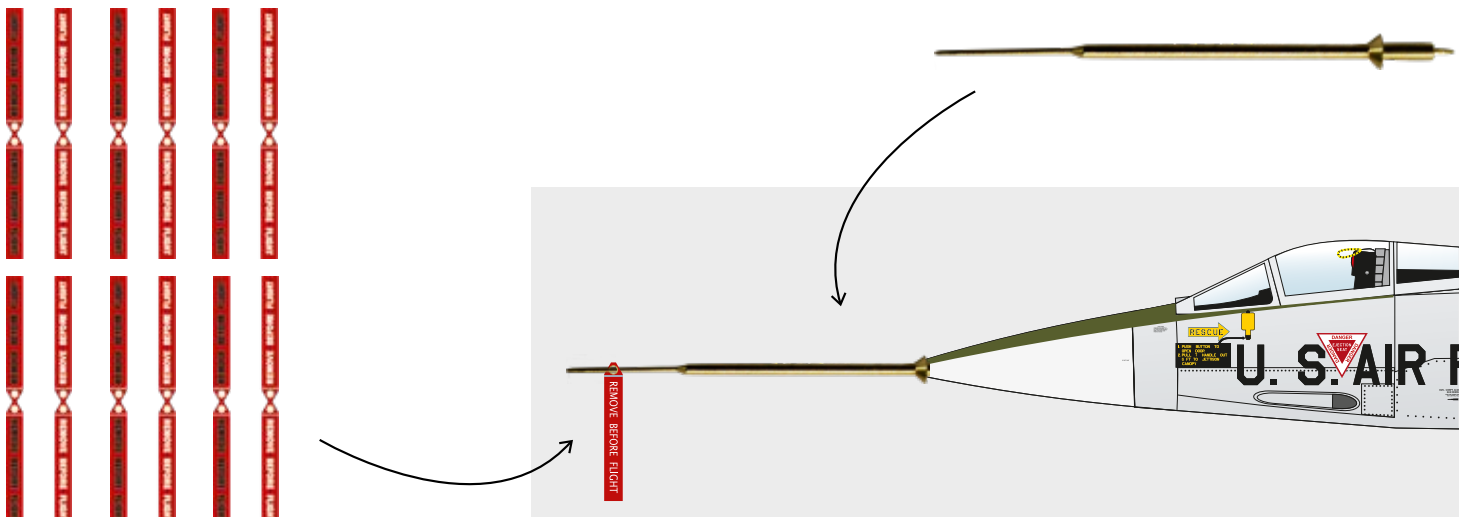

COLOR	HELLER	HUMBROL	REVELL	GSI CREOS MR. COLOR	AMMO MIG
Sand yellow	62	155	381	304	A.MIG-030
Rubber & Tires	85	-	9	137	A.MIG-033
Matt black	33	33	8	33	A.MIG-046
Satin white	130	22	301	1	A.MIG-047
Yellow	69	69	12	4	A.MIG-048
Red	19	153	330	3	A.MIG-049
Khaki	93	26	86	H404	A.MIG-071
Nato green	102	117	46	54	A.MIG-084
RAL 6014 Yellow olive	-	-	-	-	A.MIG-087
Crystal green	325	-	-	138	A.MIG-092
Crystal red	321	220	731	47	A.MIG-093
Crystal light blue	-	-	752	61	A.MIG-187
Steel	87	27003	57	28	A.MIG-191
Bluish Titanium	-	-	-	-	A.MIG-193
Silver	11	11	90	8	A.MIG-195
FS 36375 Ghost gray	127	-	374	308	A.MIG-203
Gunship gray	87	125	74	305	A.MIG-204
FS26231 Gray	27	27	57	317	A.MIG-205
RLM81, FS34079, BS641 Brown violet	-	-	-	330	A.MIG-206
FS26373 Silver grey	53	-	99	332	A.MIG-212
FS33481 Zinc chromate yellow	-	-	-	27	A.MIG-221
FS36152, AMT-12 Dark grey	5	-	378	32	A.MIG-235
FS36122 Neutral grey	64	-	374	13	A.MIG-239
ALC107 Chrome for plastic	-	191	-	SM08	A.MIG-8205
Aluminium	56	56	91	H218	A.MIG-0194
Grass green matt	80	80	360	H58	A.MIG-0054
US dark green matt	116	116	361	H309	A.MIG-0233
Dark green matt	30	30	-	H73	A.MIG-0052
Mid green matt	101	101	364	H319	A.MIG-0238
Brown matt	186	186	-	-	A.MIG-0073
Orange gloss	18	18	332	H14	A.MIG-0129
White gloss	22	22	4	H316	A.MIG-0047

PEINTURES ESSENTIELLES / ESSENTIAL PAINTS

Disponibles chez votre revendeur de maquettes. / Available at you local hobby shop.



11
Argent metallique
Silver Metallic
Silber metallisch



18
Orange brillant
Orange Gloss
Orange glänzend



22
Blanc brillant
White Gloss
Weiß glänzend



30
Vert fonce mat
Dark Green Matt
Dunkelgrün matt



33
Noir mat
Black Matt
Schwarz matt



56
Aluminium metallique
Aluminium Metalli
Aluminium metallisch



80
Vert pre mat
Grass Green Matt
Grasgrün matt



93
Jaune desert mat
Desert Yellow Matt
Wüstensand matt



101
Ivoire brillant Gloss ivory
Glänzend-Elfenbein



116
Ivoire brillant Gloss ivory
Glänzend-Elfenbein



127
Gris fantome US satine
US Ghost Grey Satin
US-Schattengrau seidenmatt



130
Blanc satine
White Satin
Weiß seidenmatt



186
Ivoire brillant Gloss ivory
Glänzend-Elfenbein

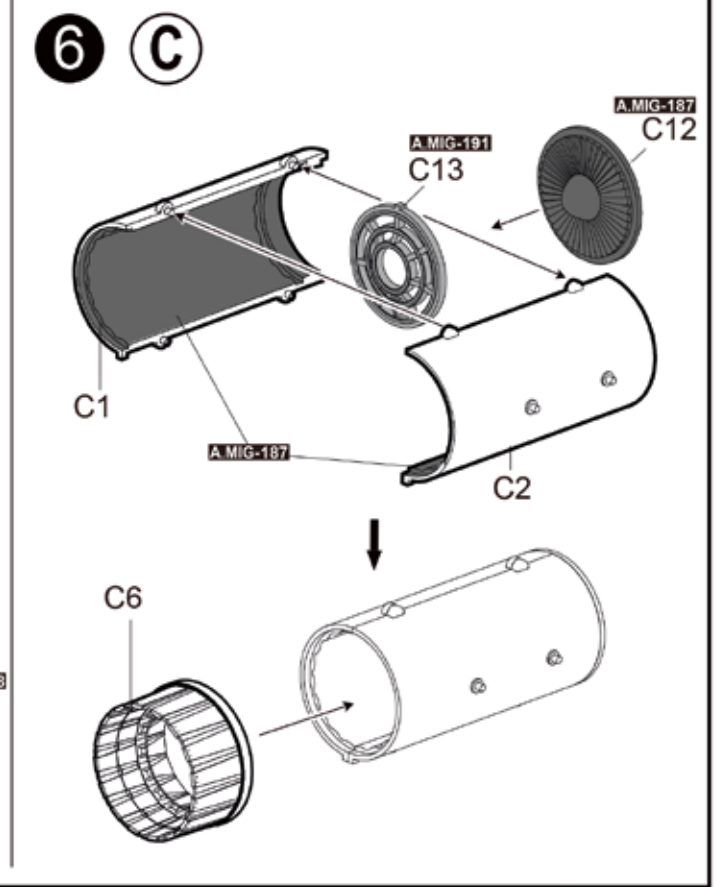
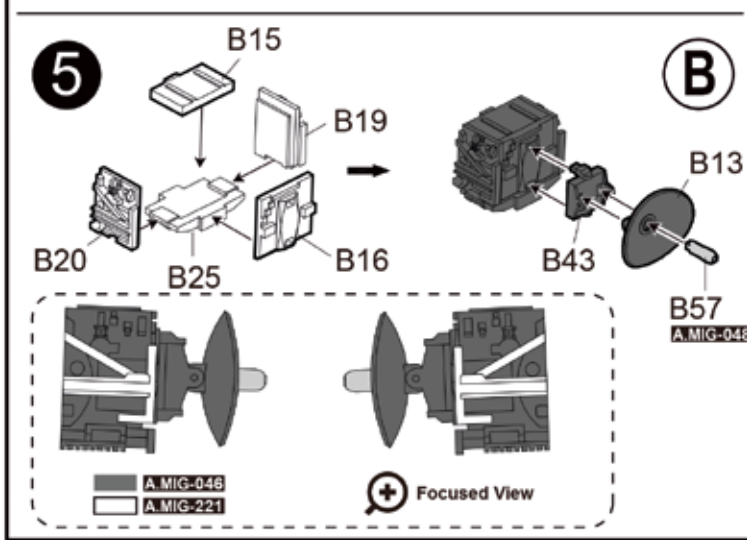
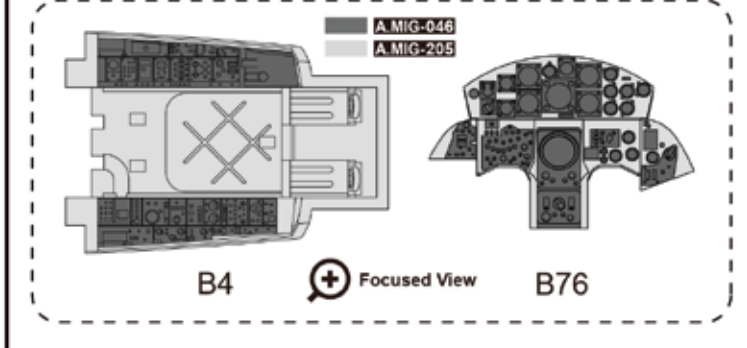
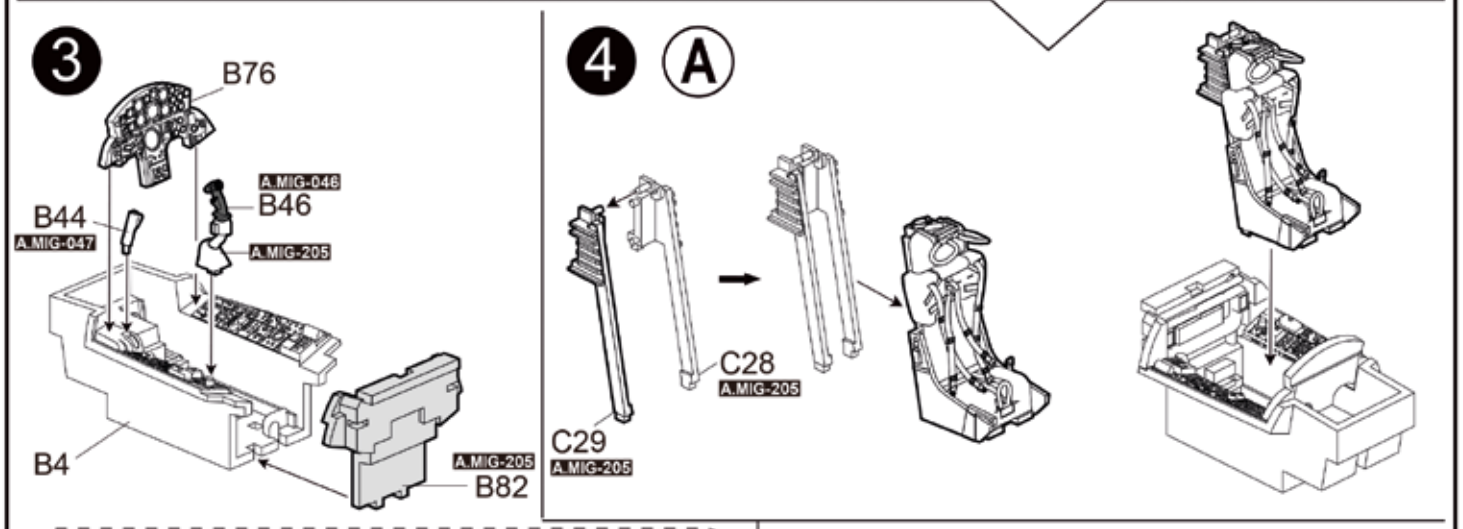
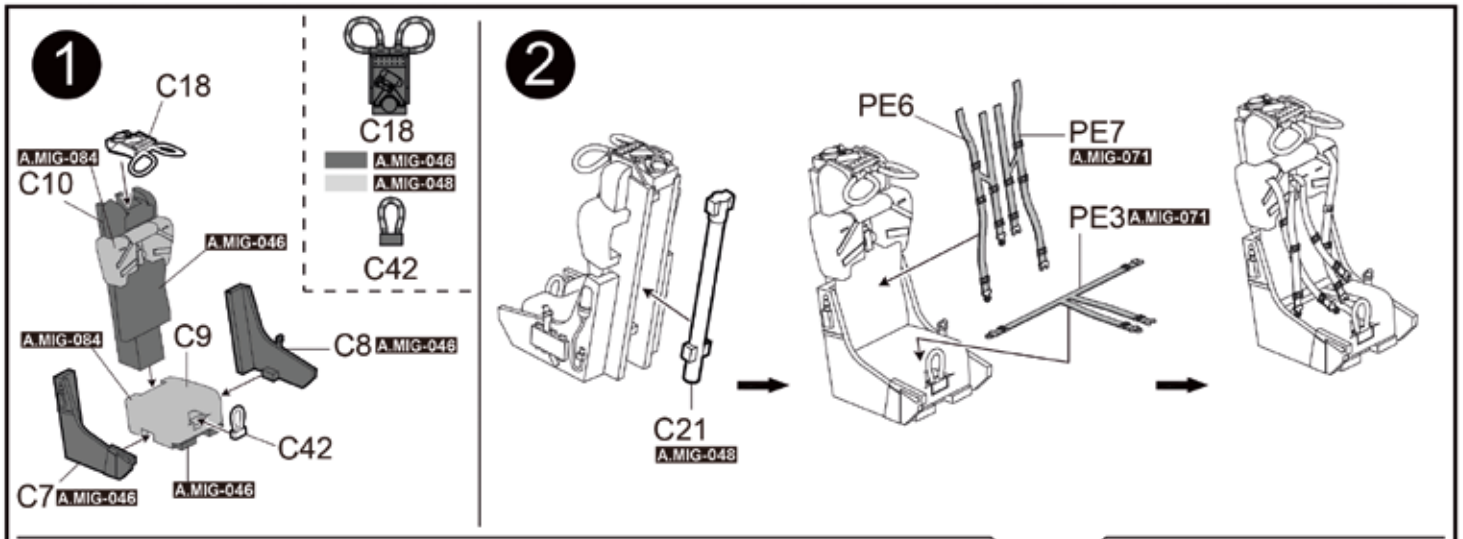

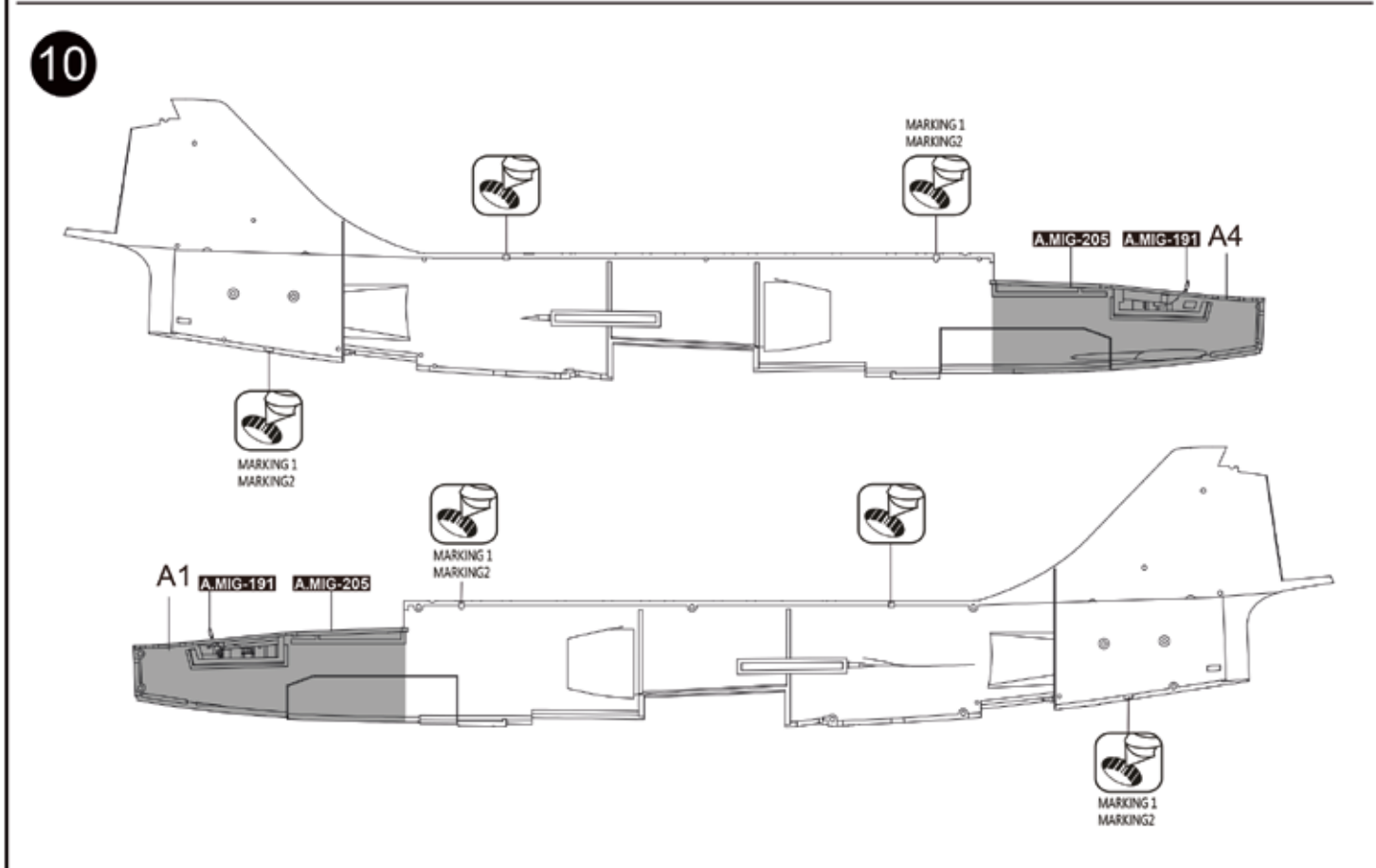
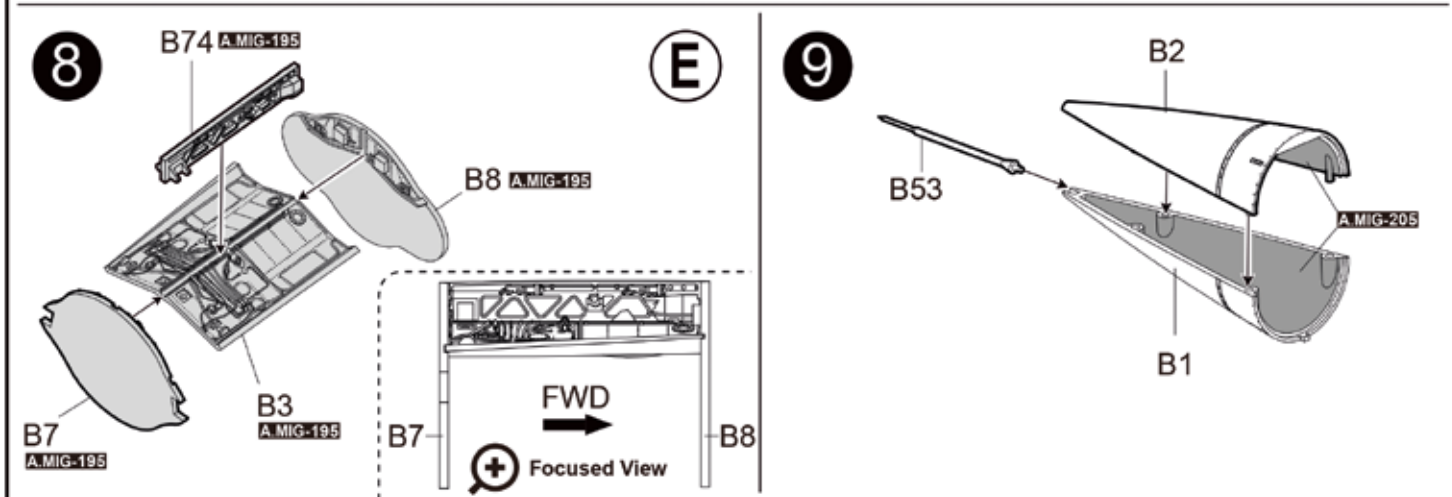
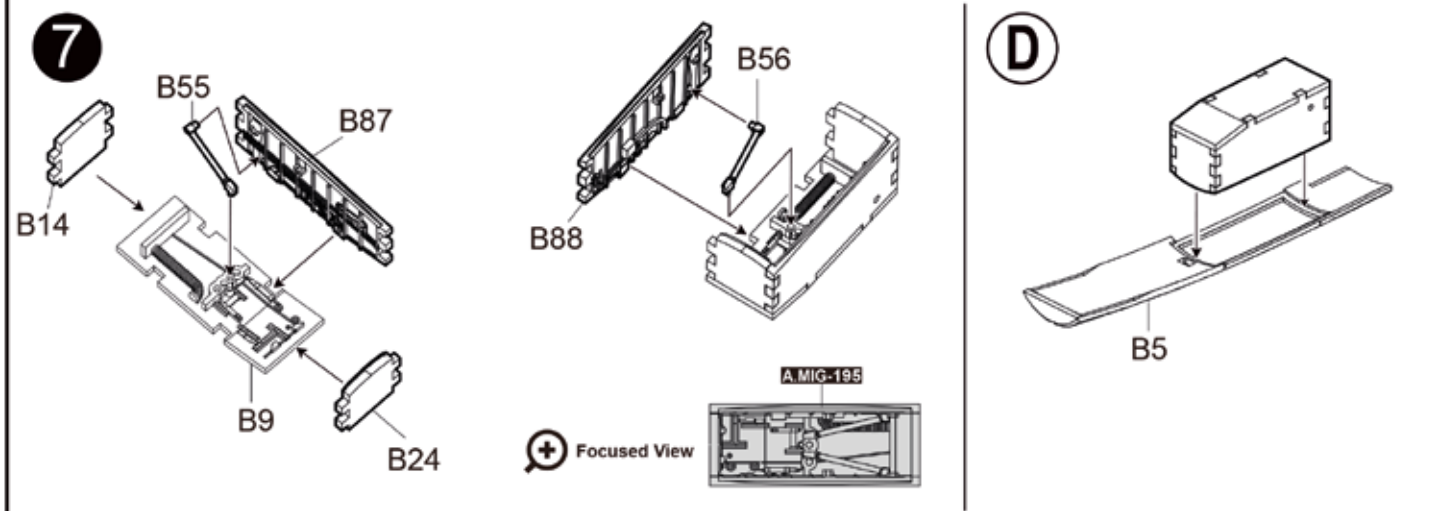

11

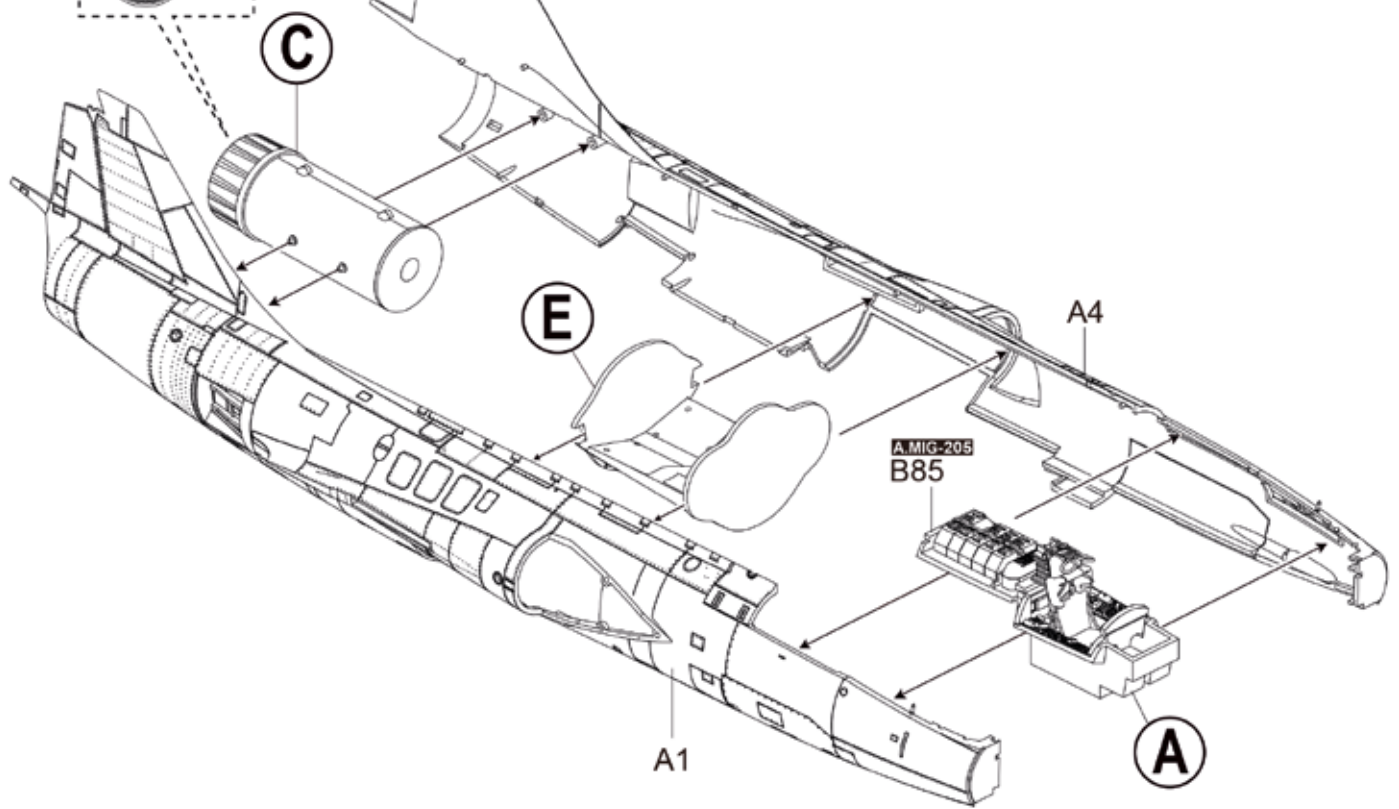

12

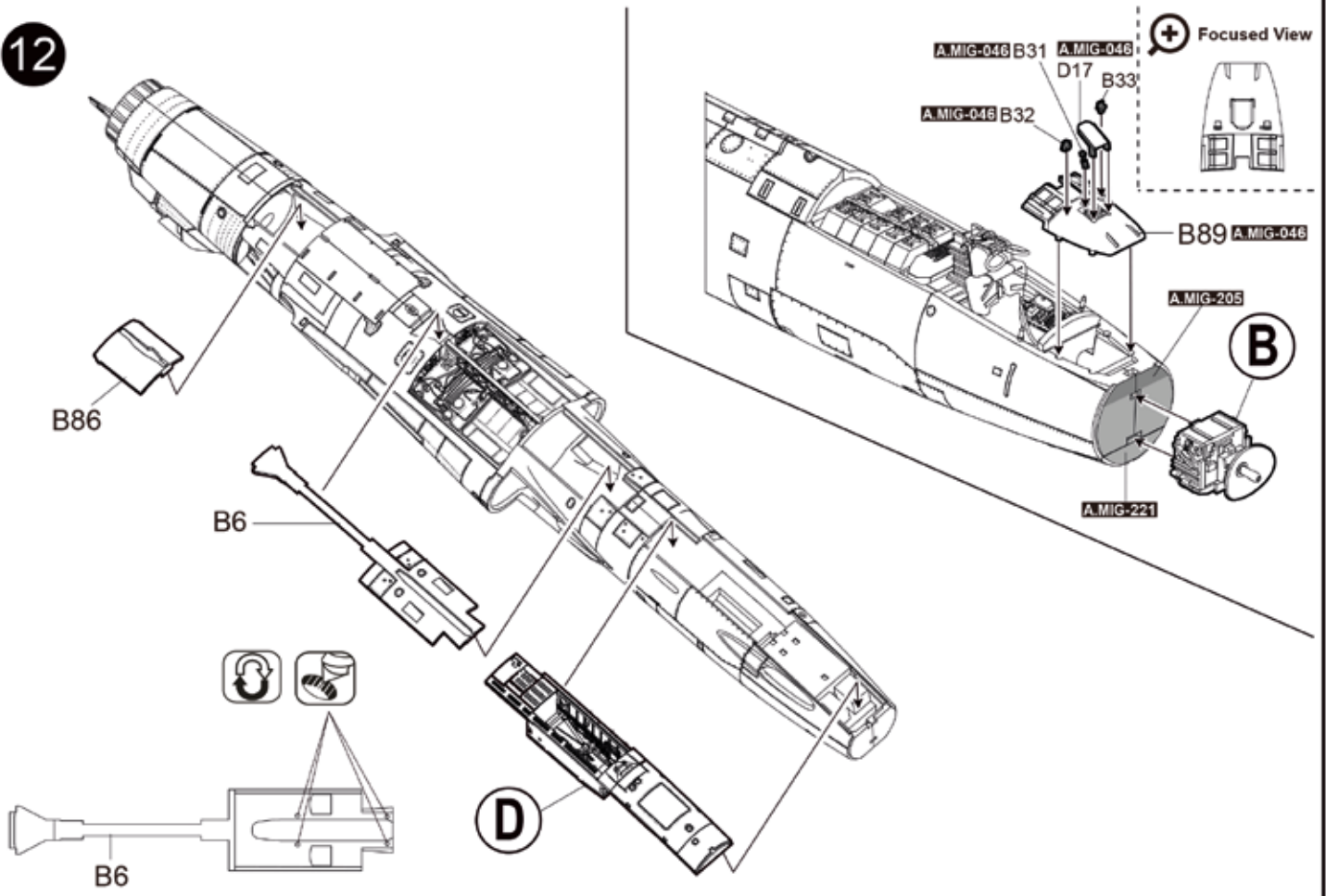

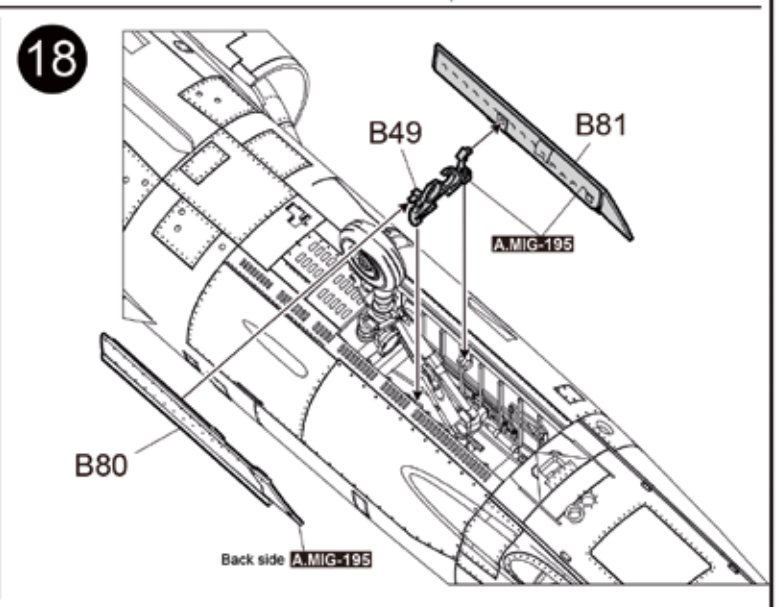
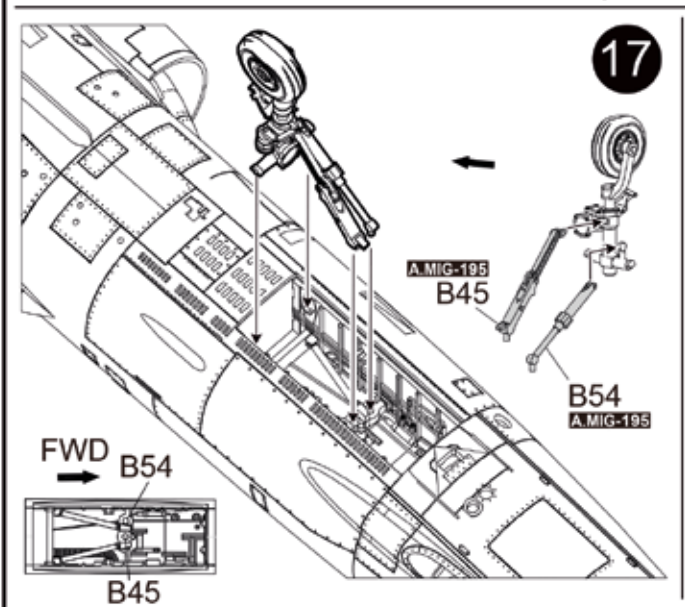
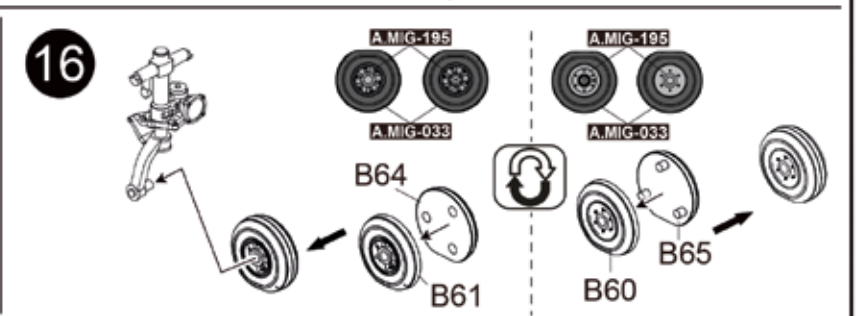
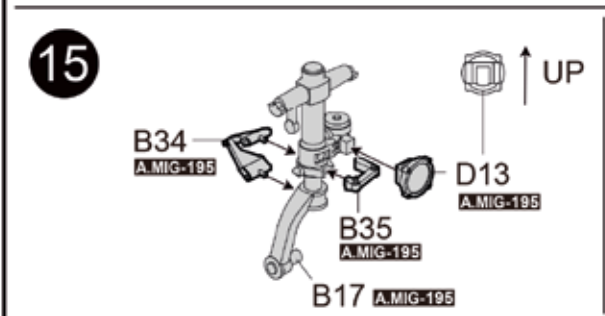
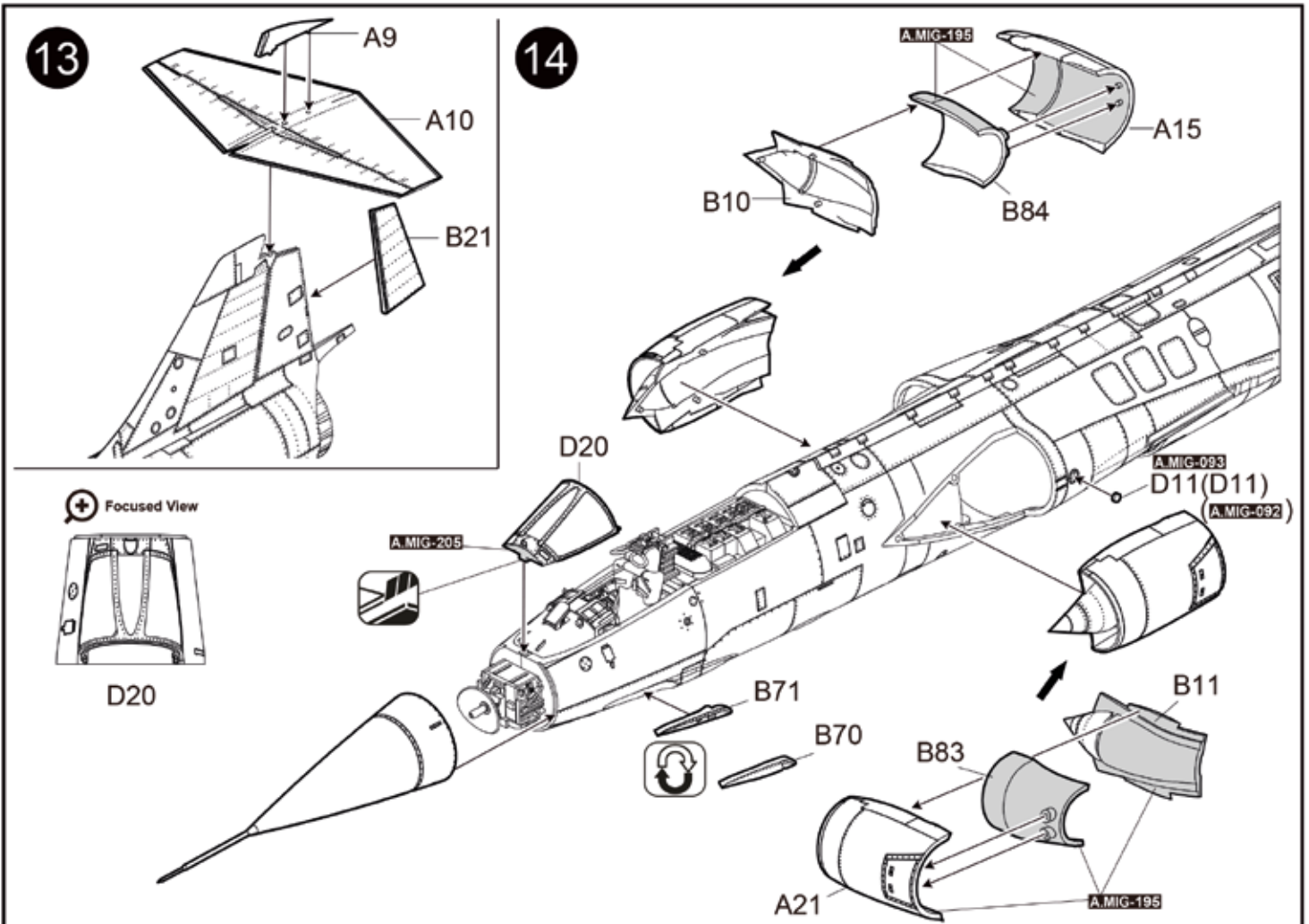

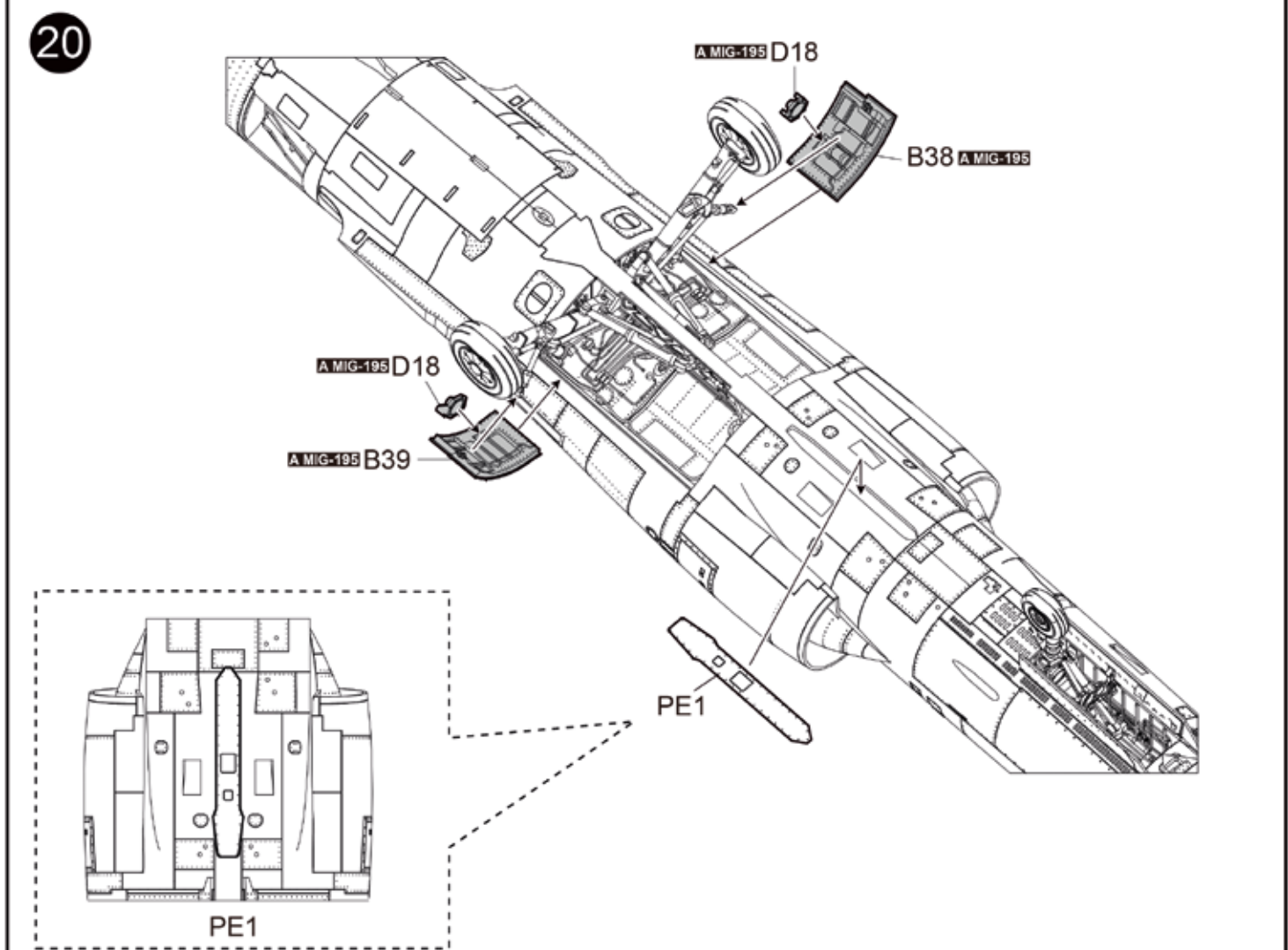
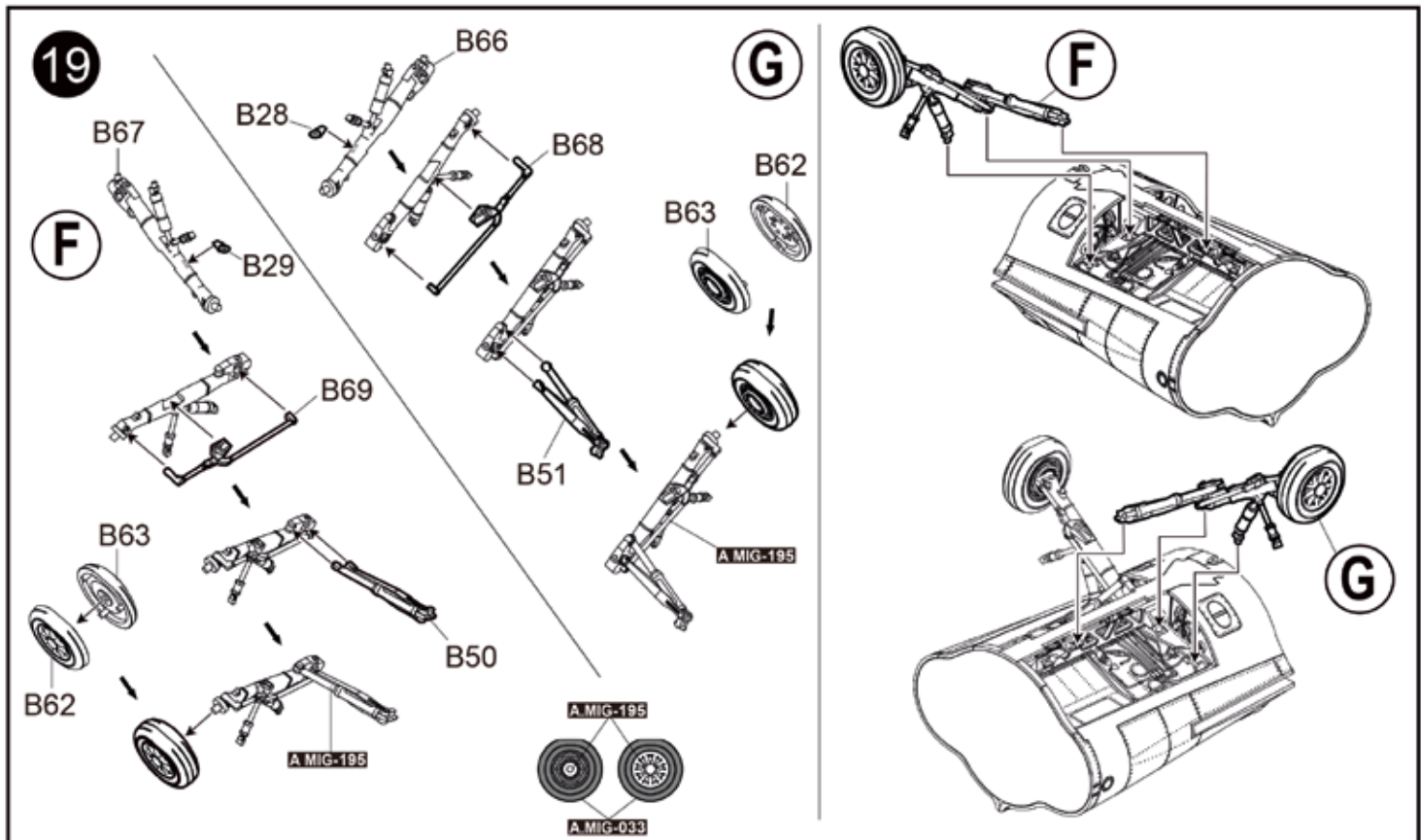

21

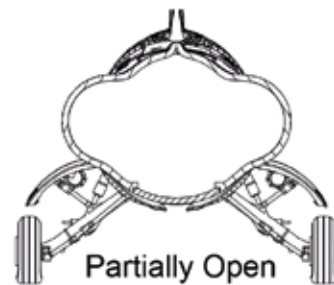
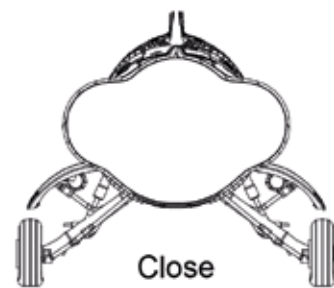
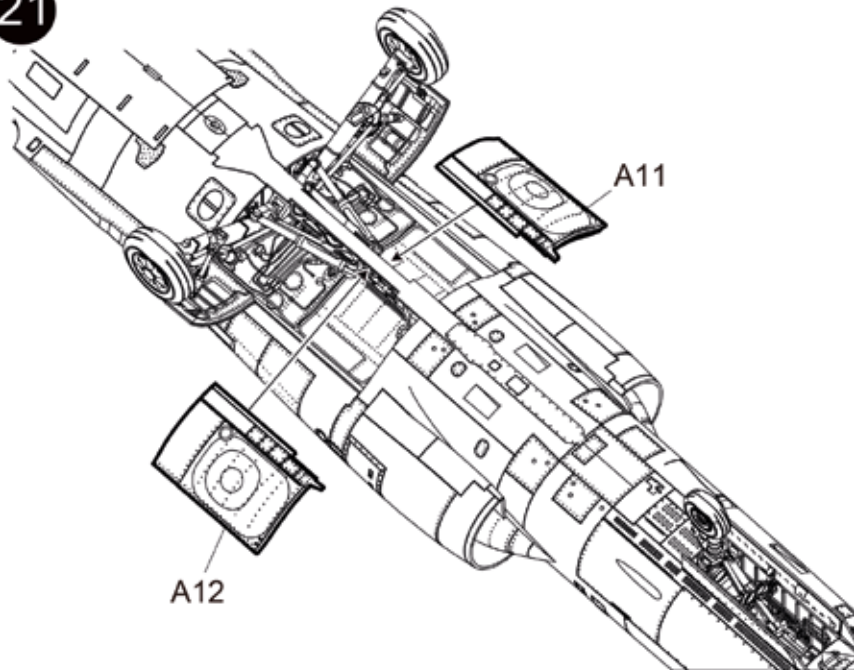

22

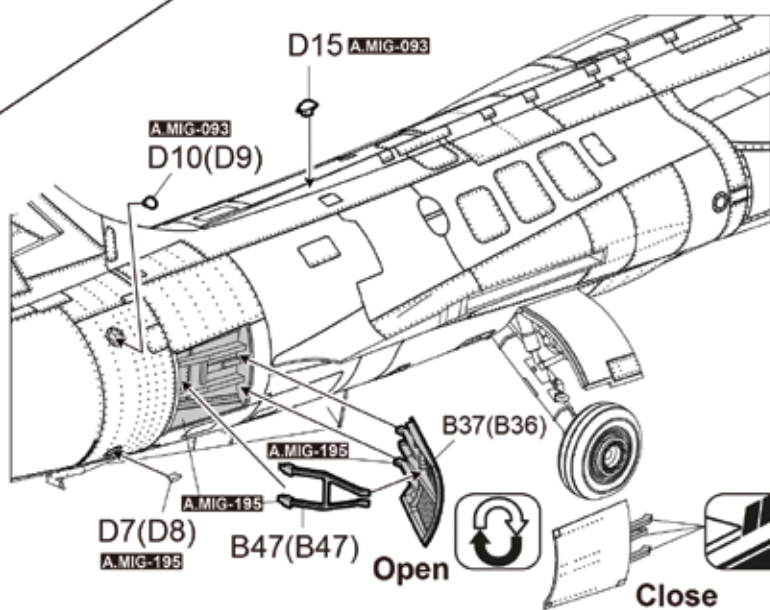
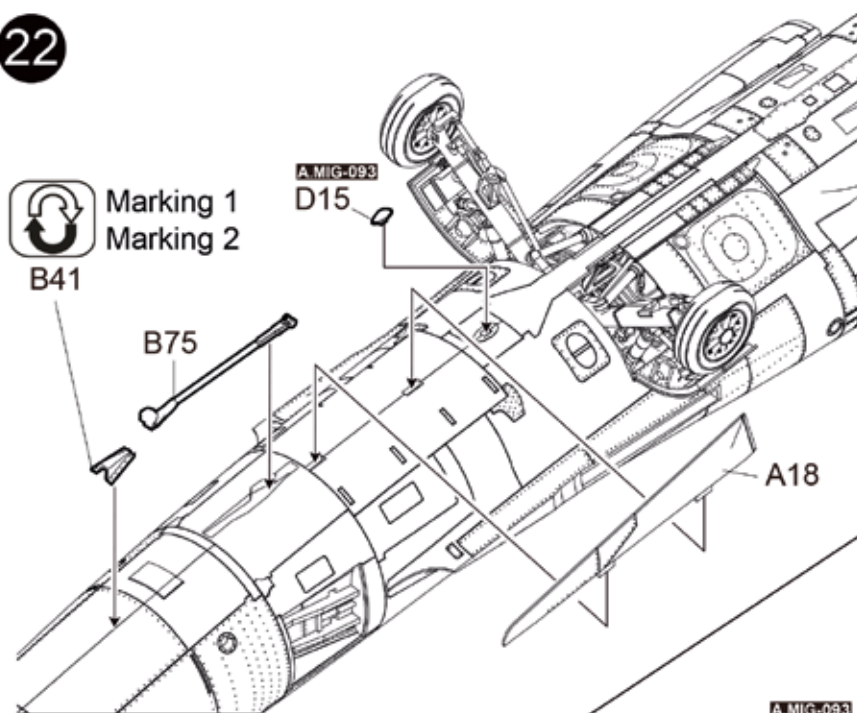

23

24

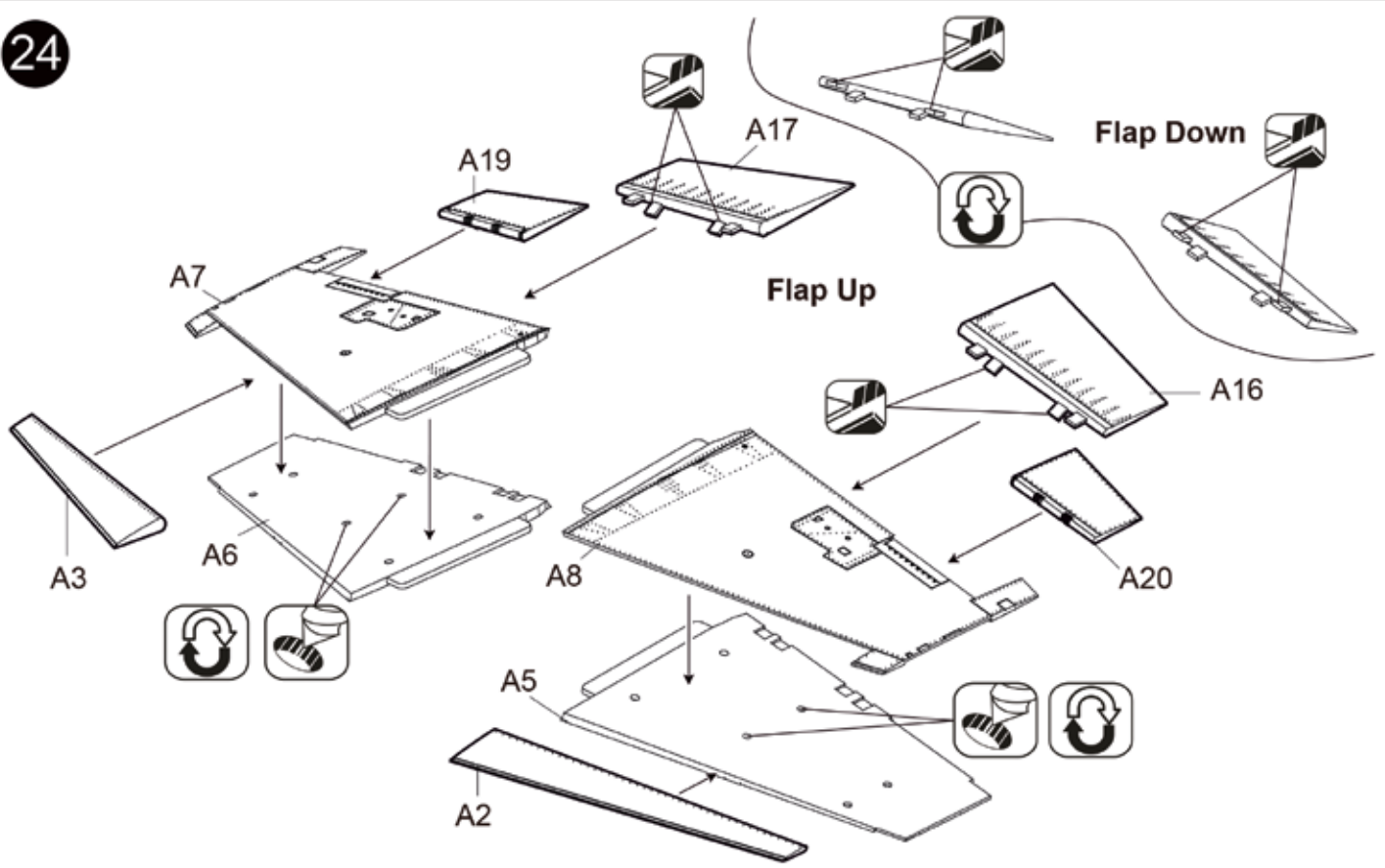

25

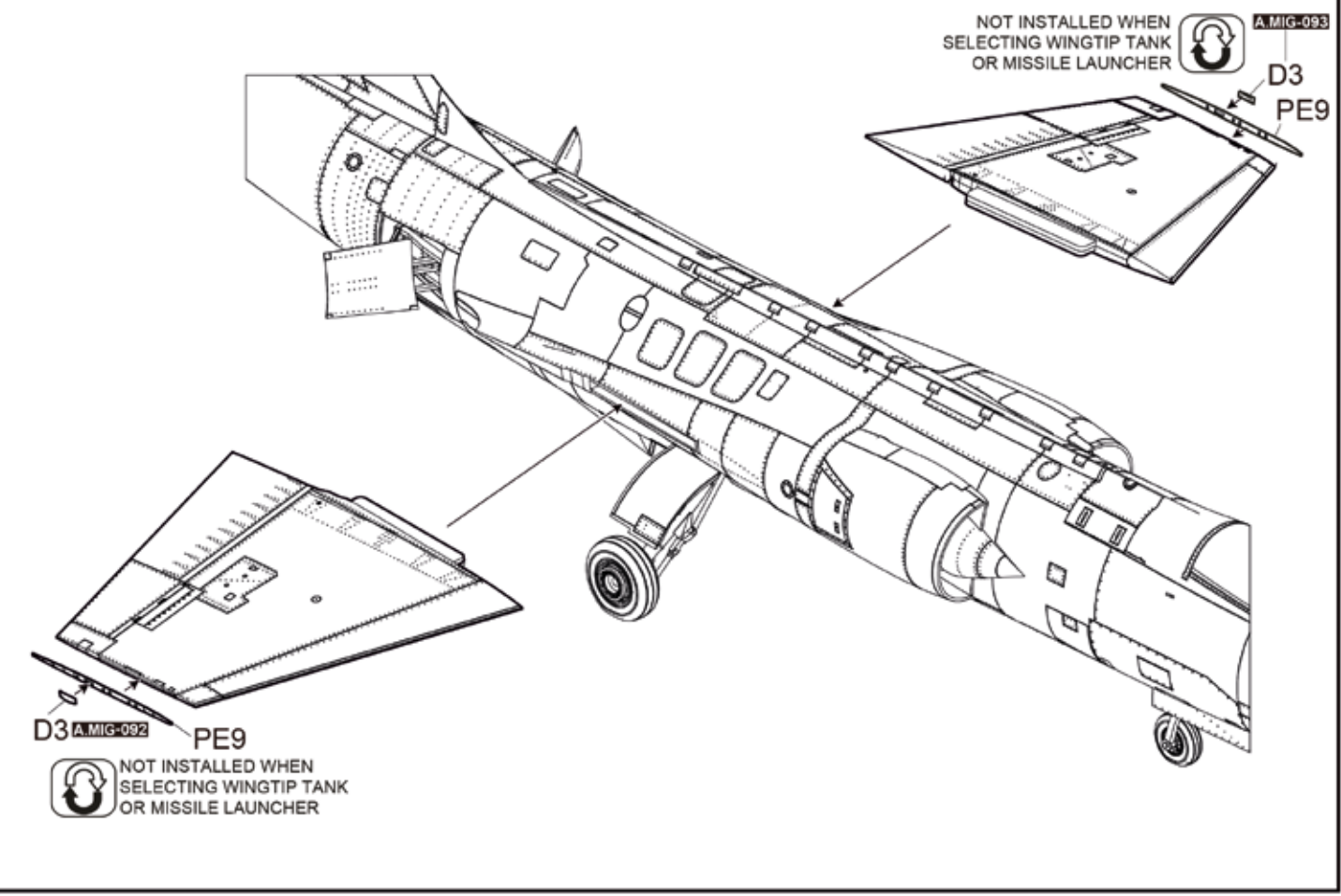

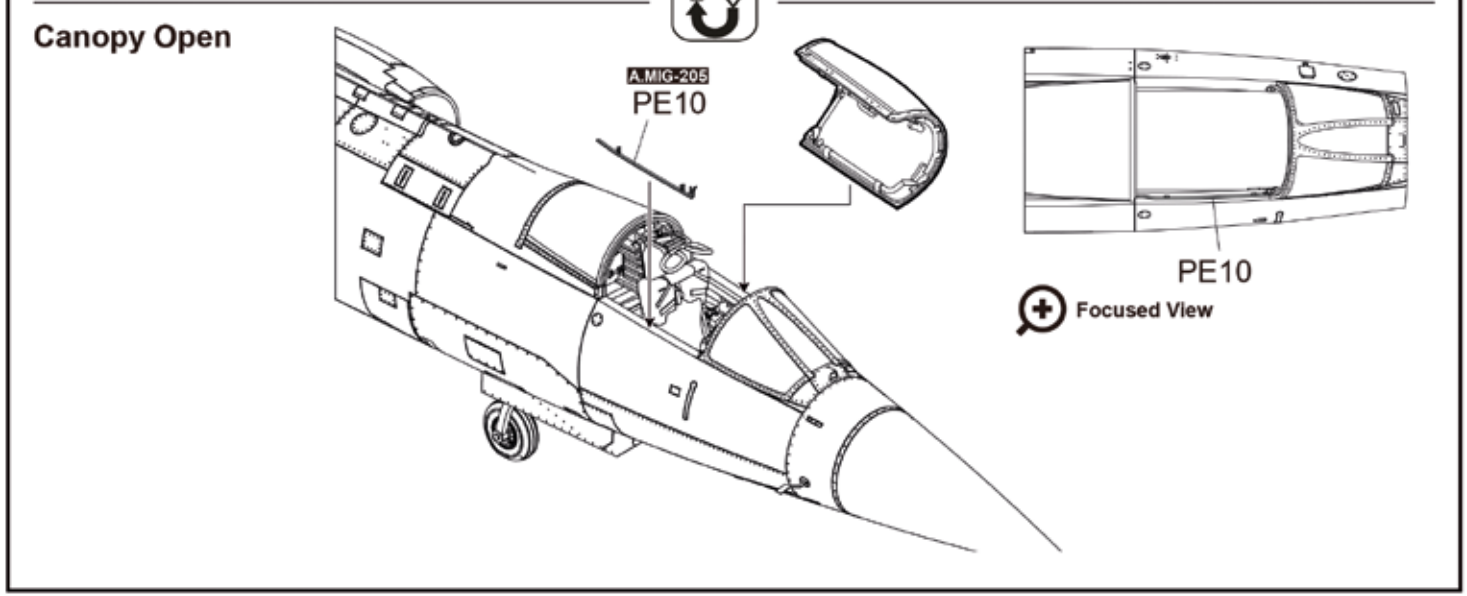
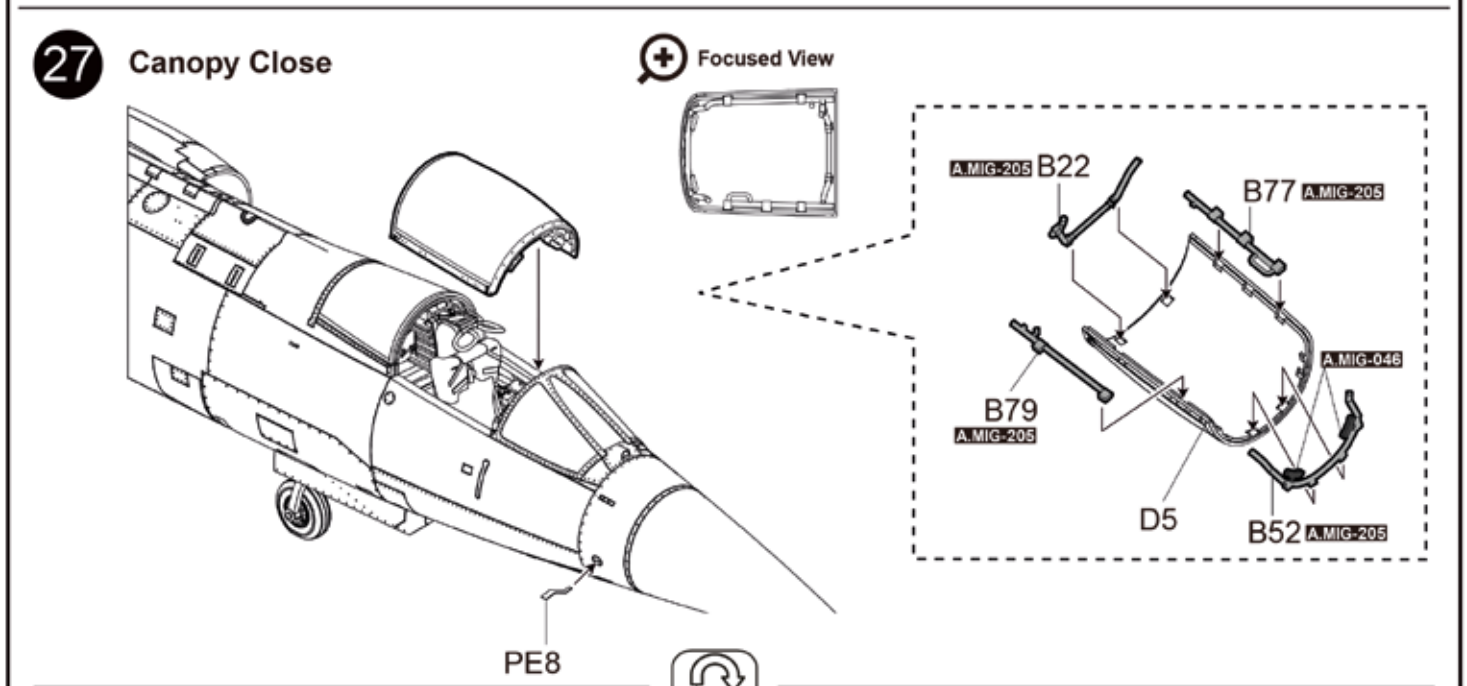
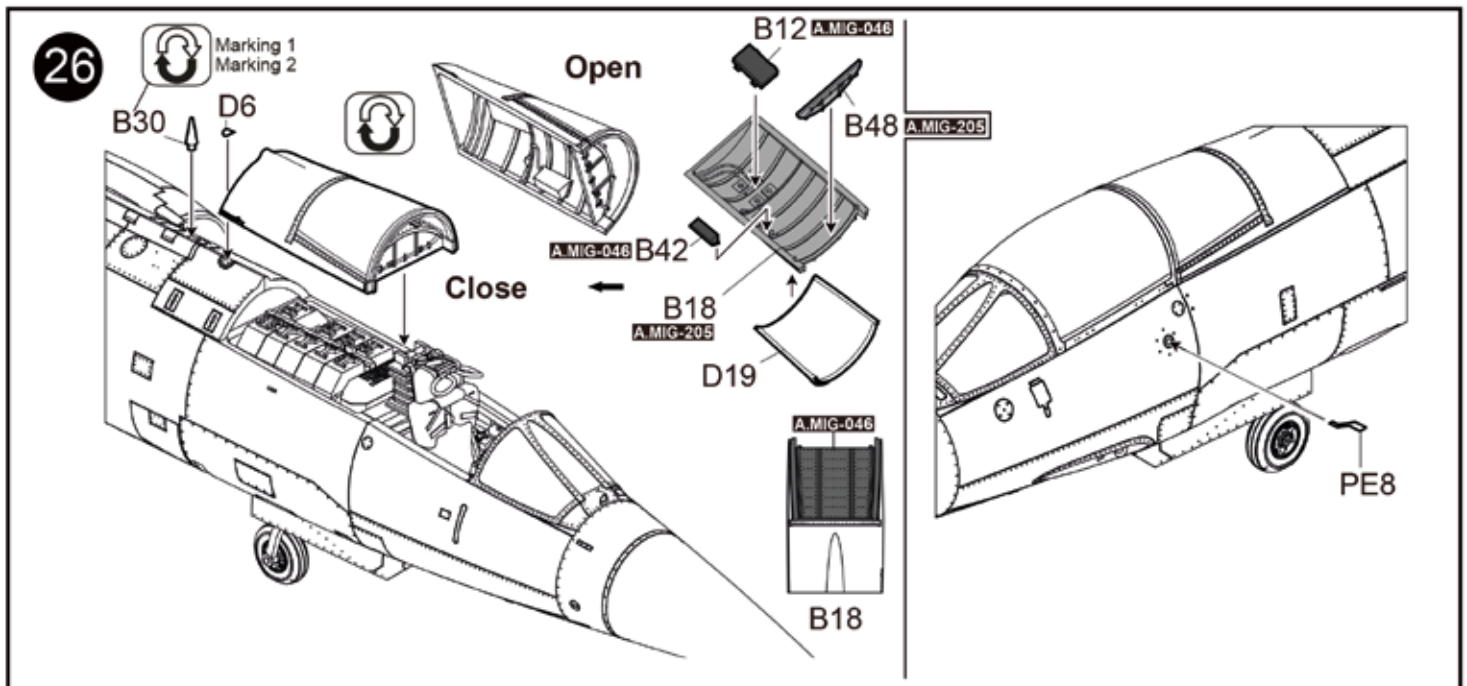

28

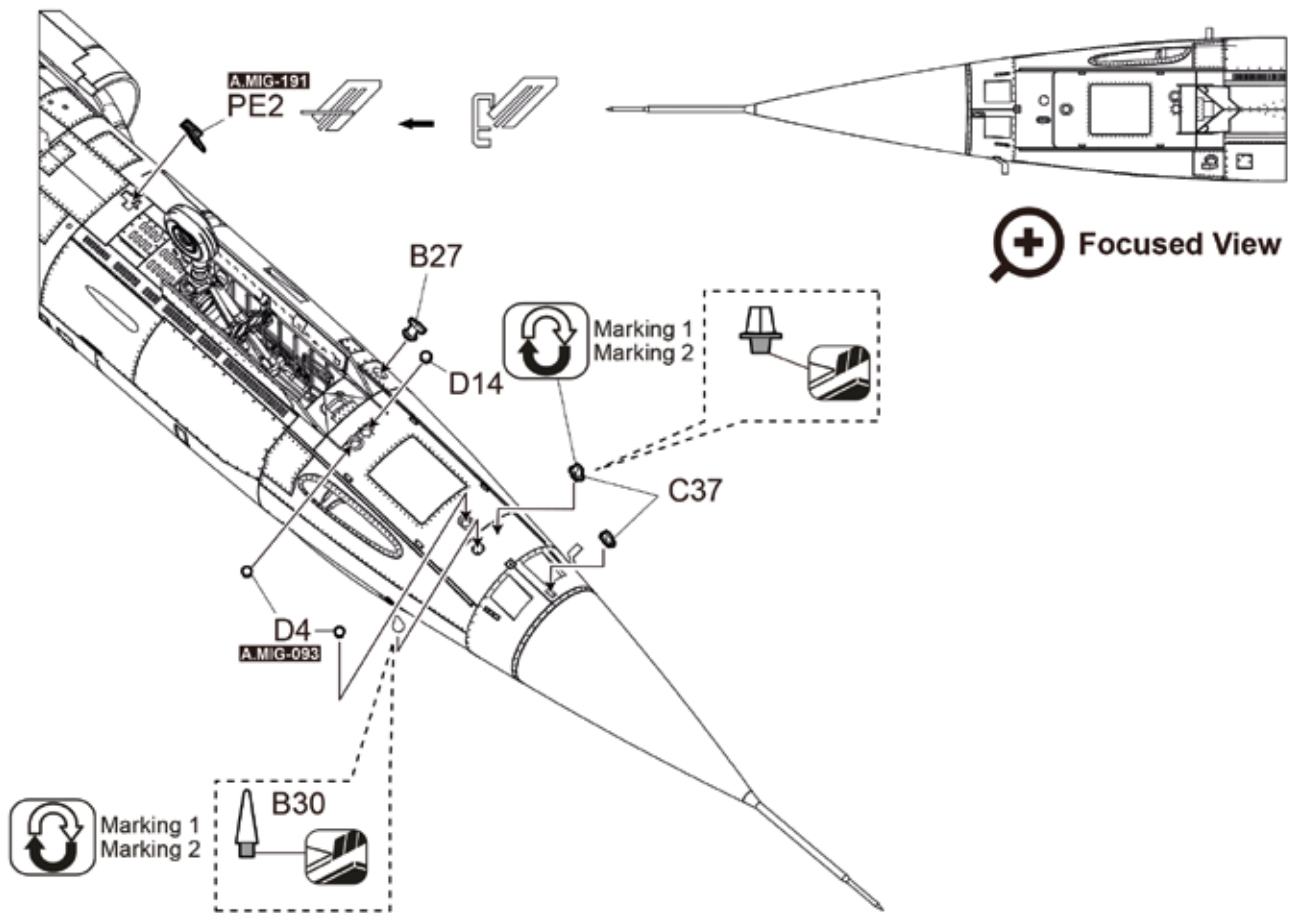

29

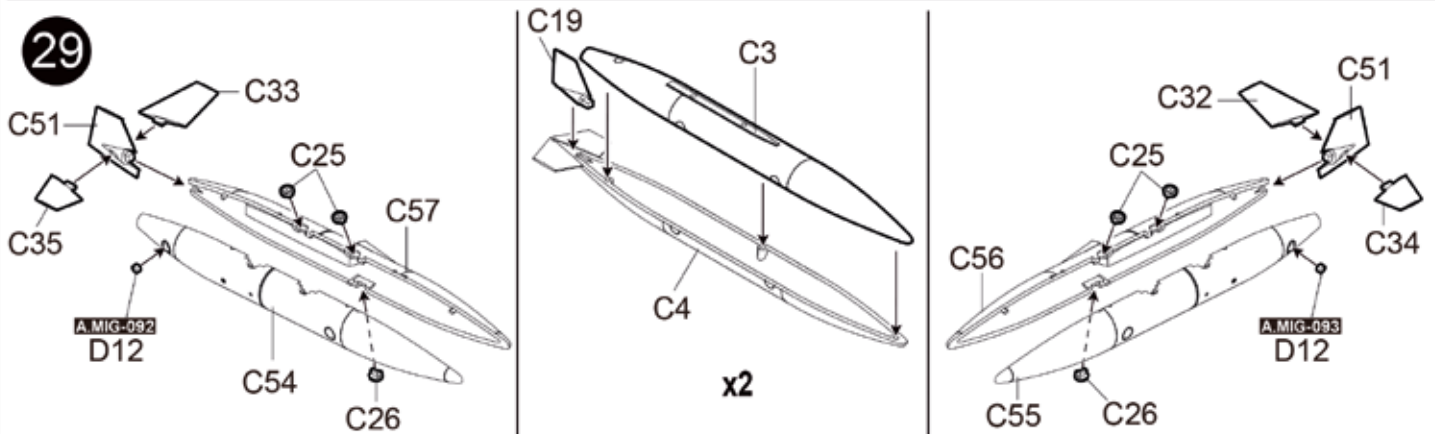

AERO-3B

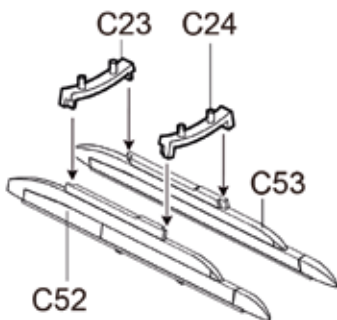

30

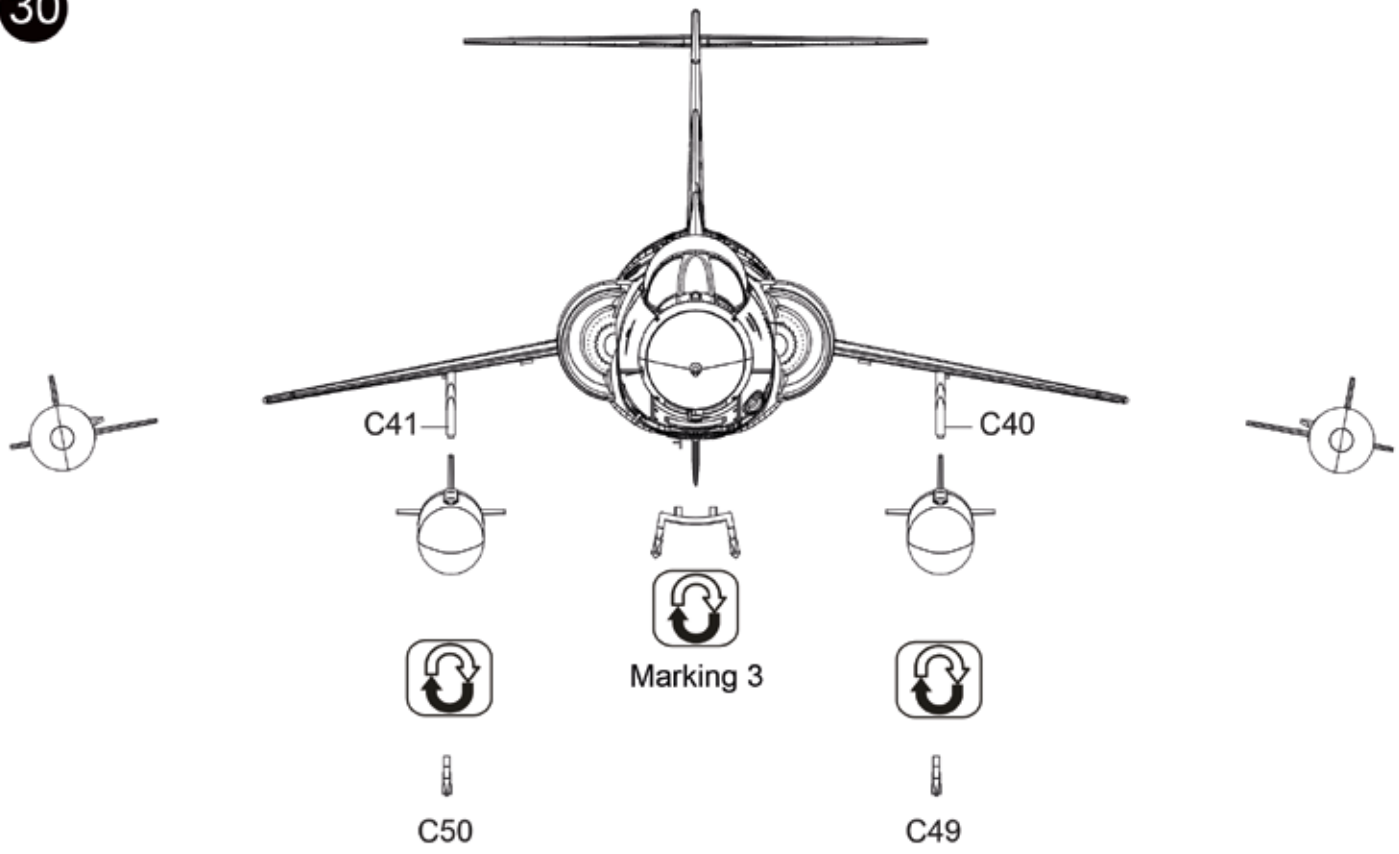

*Lockheed F-104G, USAF s/n 63-13269
Luke AFB, 58th TFW, 1982*

- | | | | | | | | |
|----|----|----|----|-----|--------------------|----|-------------------|
| | | | | | | | |
| 11 | 33 | 56 | 80 | 127 | 130 | M1 | M2 |
| | | | | | 90% 130
10% 127 | | 90% 80
10% 130 |

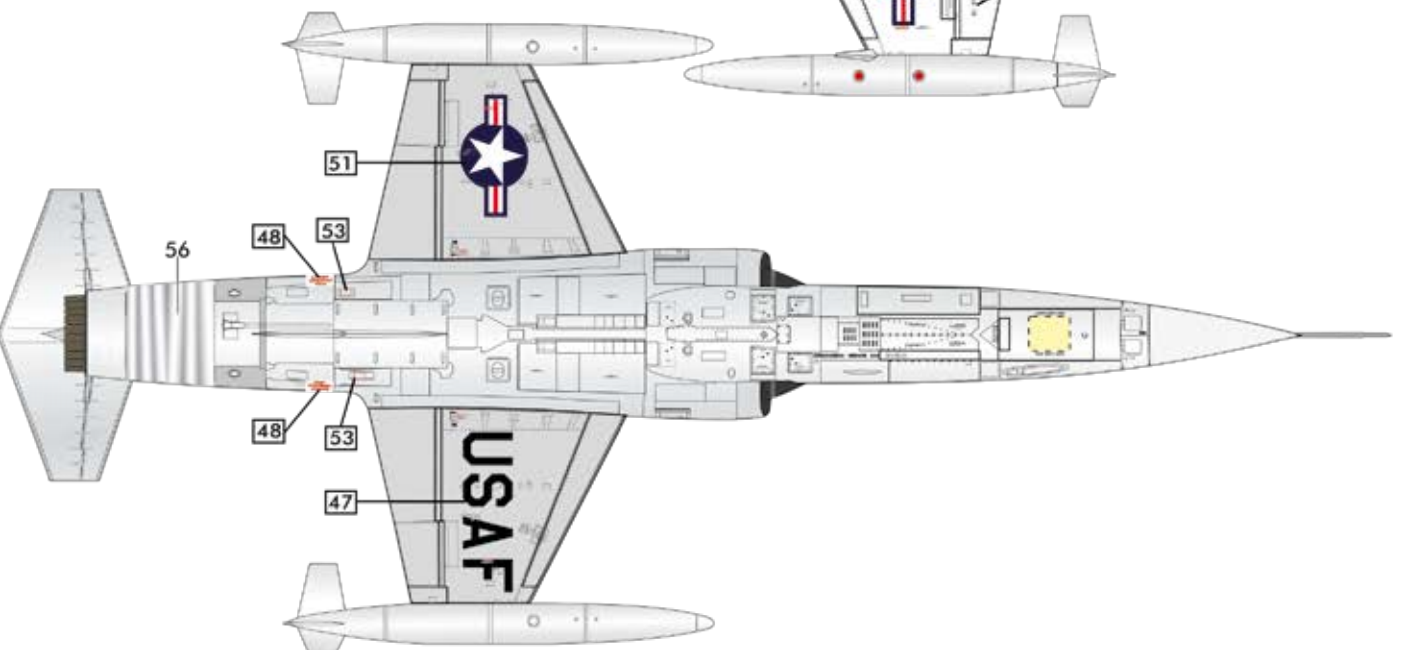
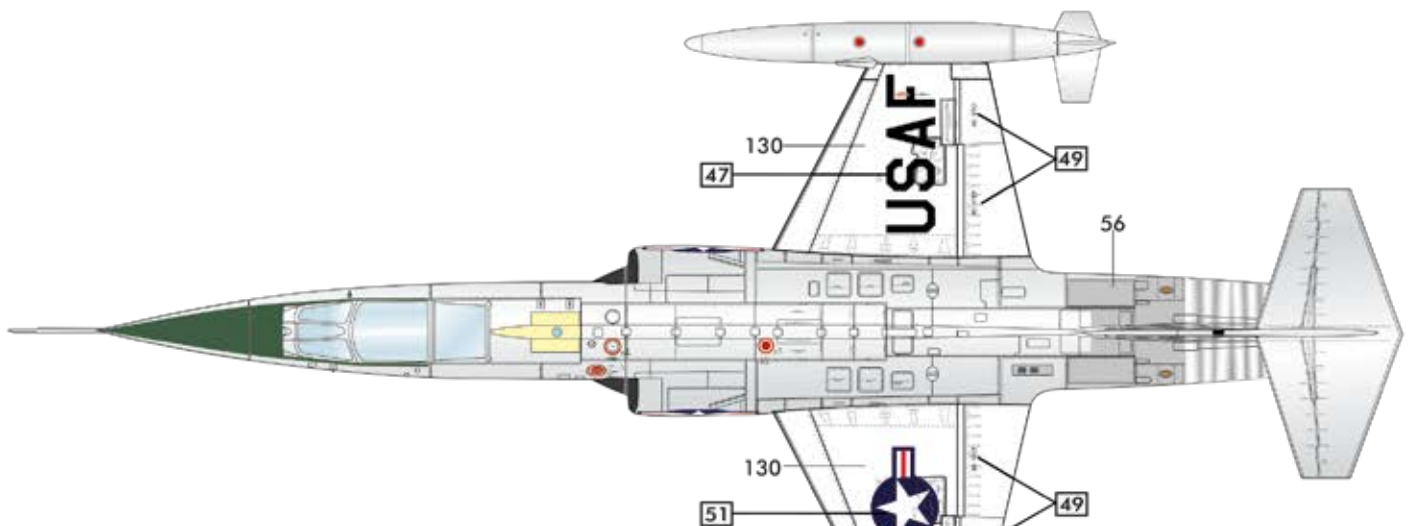
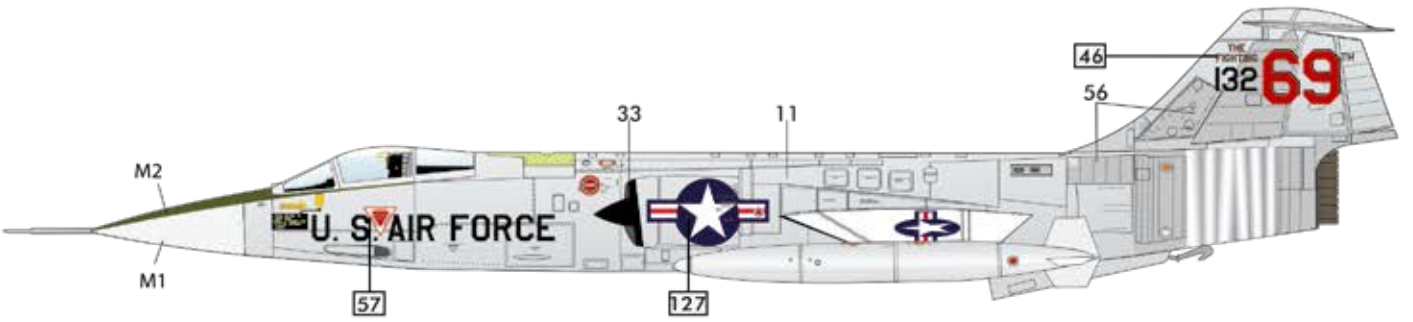
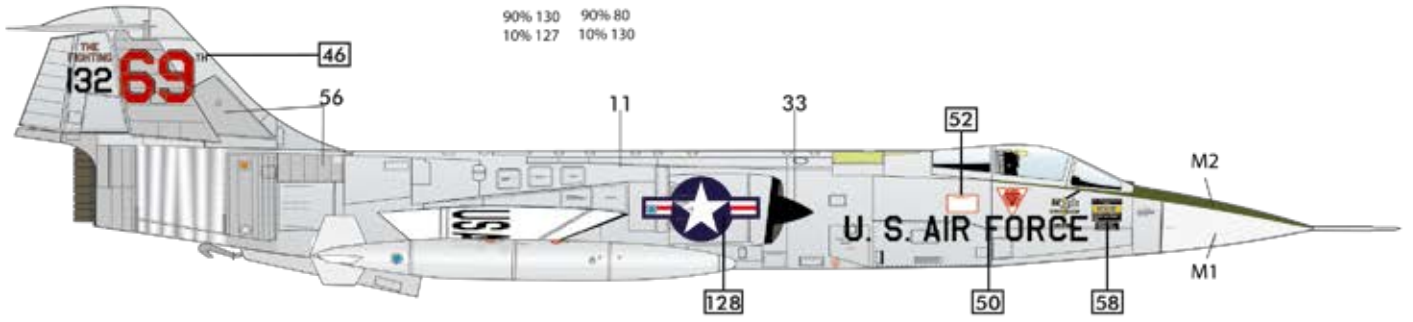

33	116	M1	M2	M3	M4	M5
RAL 9005	RAL 6014	85% 127 15% 130 RAL 7012	90% 11 10% 130 RAL 9006	90% 130 10% 127 RAL 7035	90% 80 10% 130 RAL 6007	85% 18 15% 22 RAL 2005

**Luftwaffe aircraft
F-104G Starfighter CN 8024
JG 71,,R" Wittmund AB 1973**

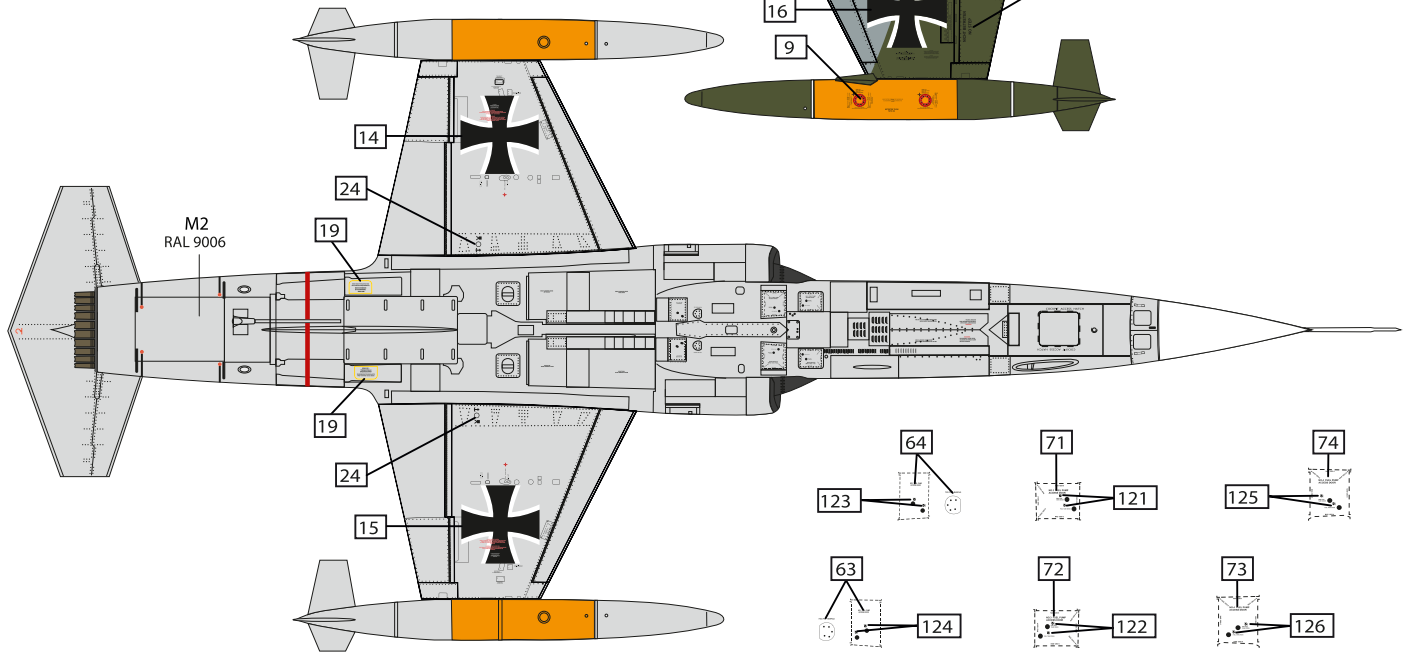
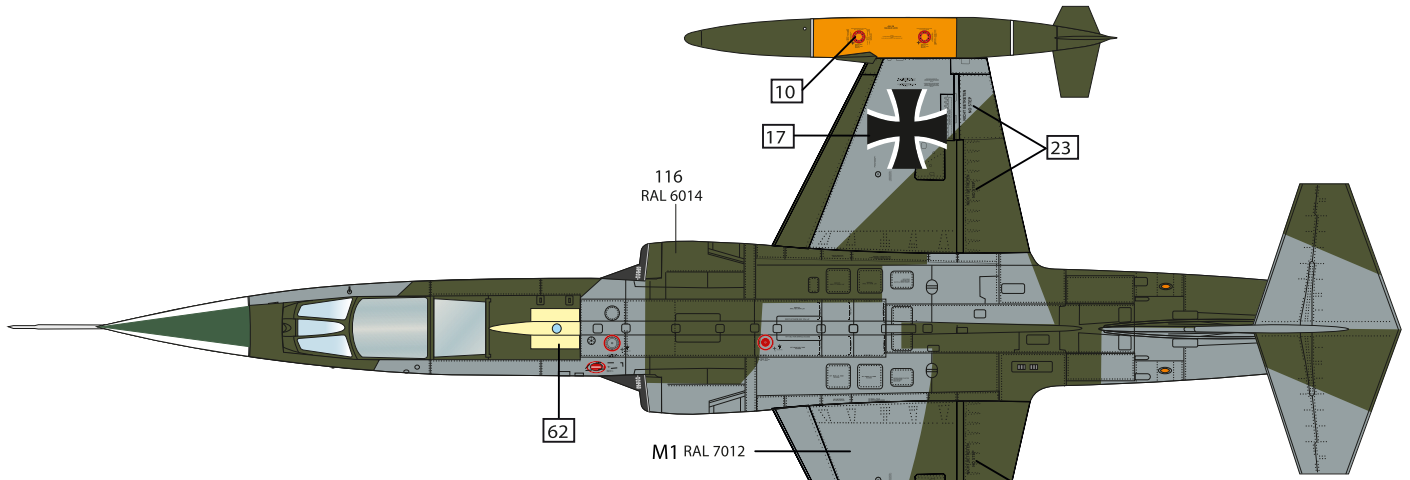
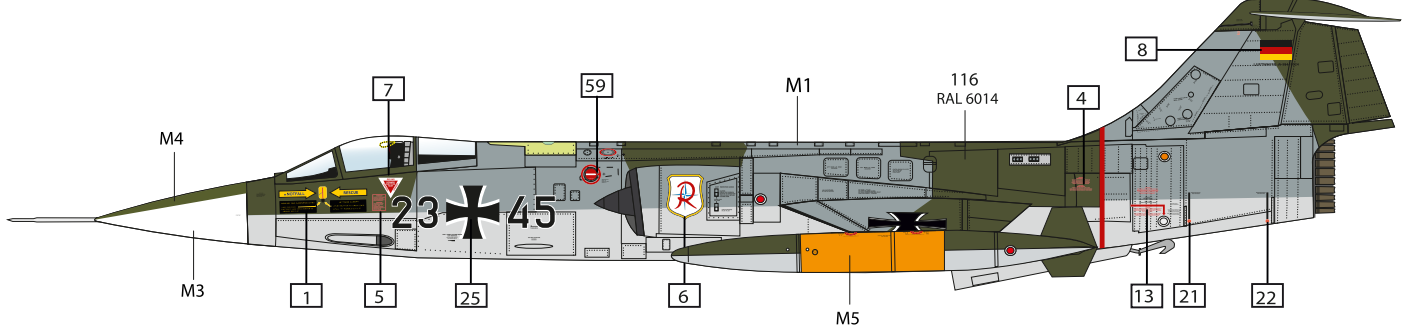
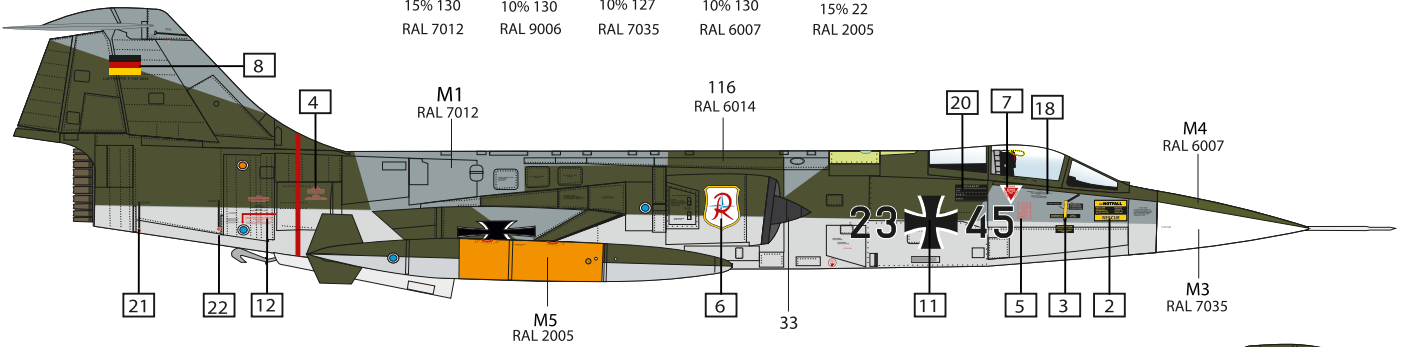

**Belgian Air Force
Lockheed F-104G, FX 74, MSN: 683-9126
Beauvechain 1981**

- | | | | |
|--------------------|-------|----------------------------|----------------------------|
| | | | |
| M1 | 116 | M2 | M3 |
| 75% 130
25% 127 | 24064 | FS 34102 | FS 30219 |
| | | 90% 30
10% 101
24012 | 90% 93
10% 186
20219 |

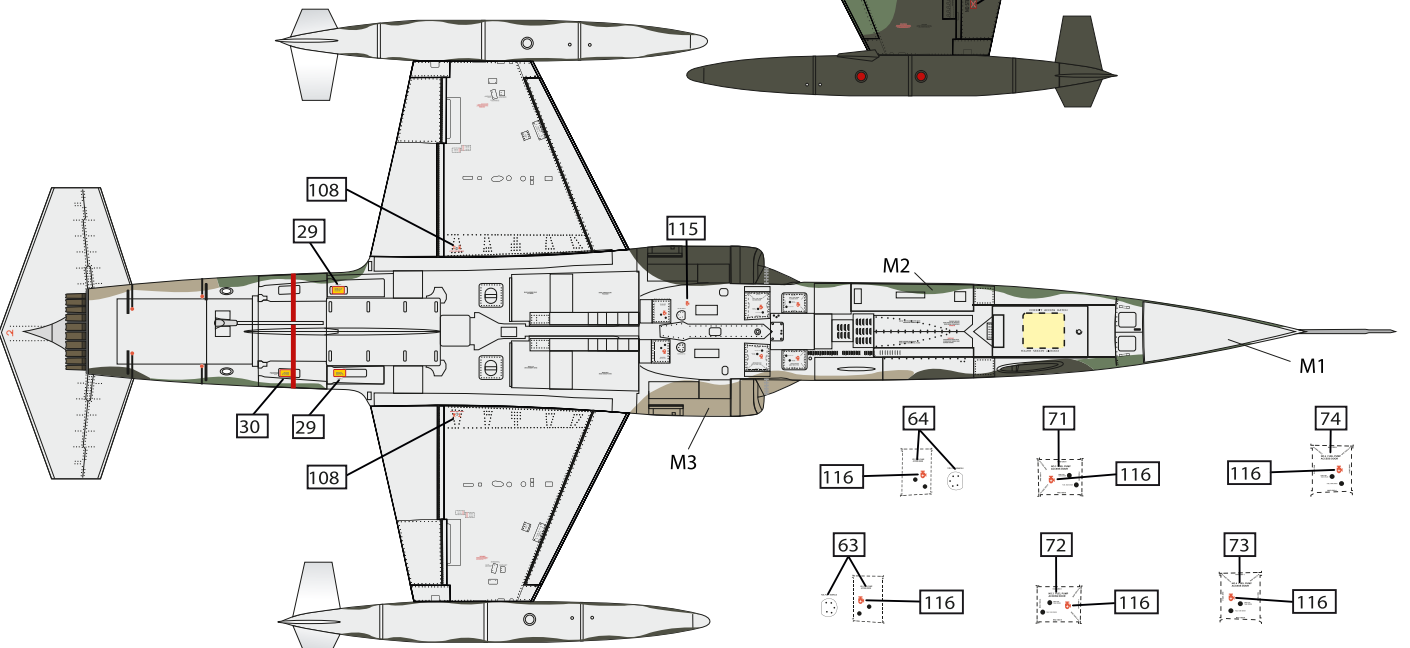
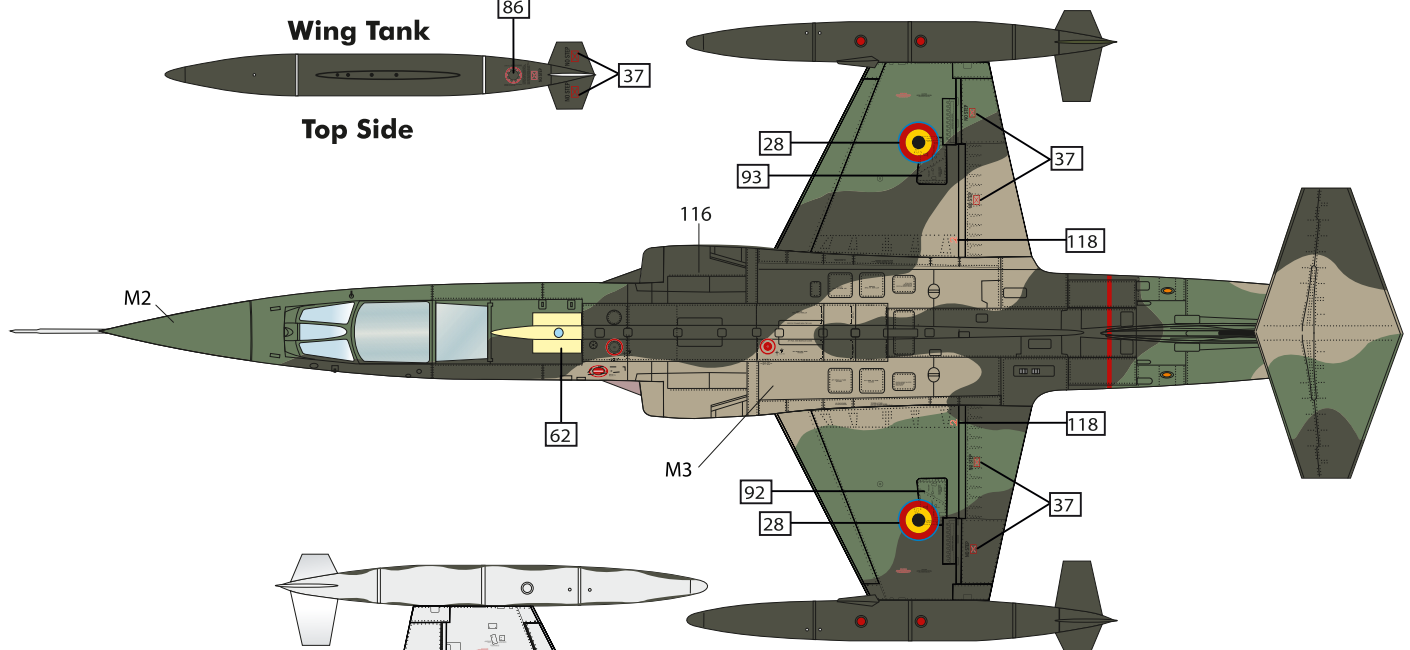
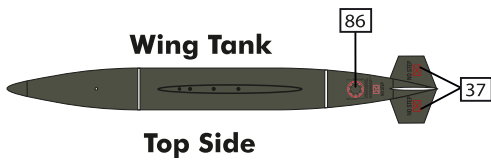
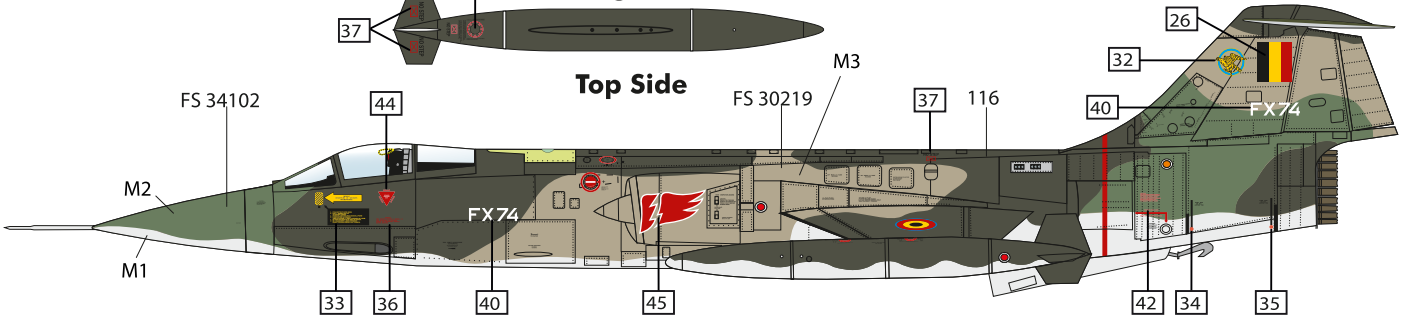
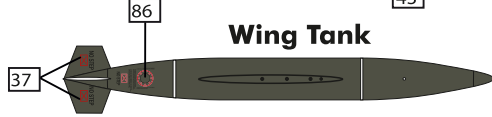
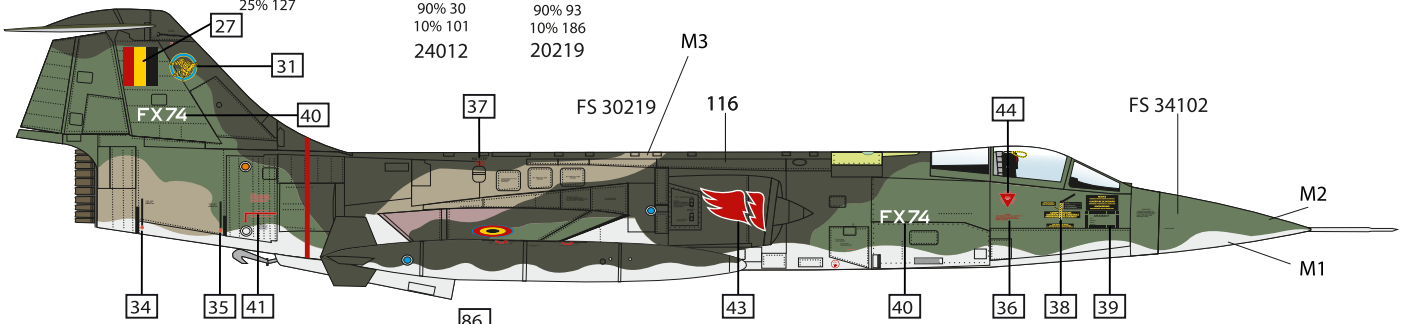

F-104G Common Decals

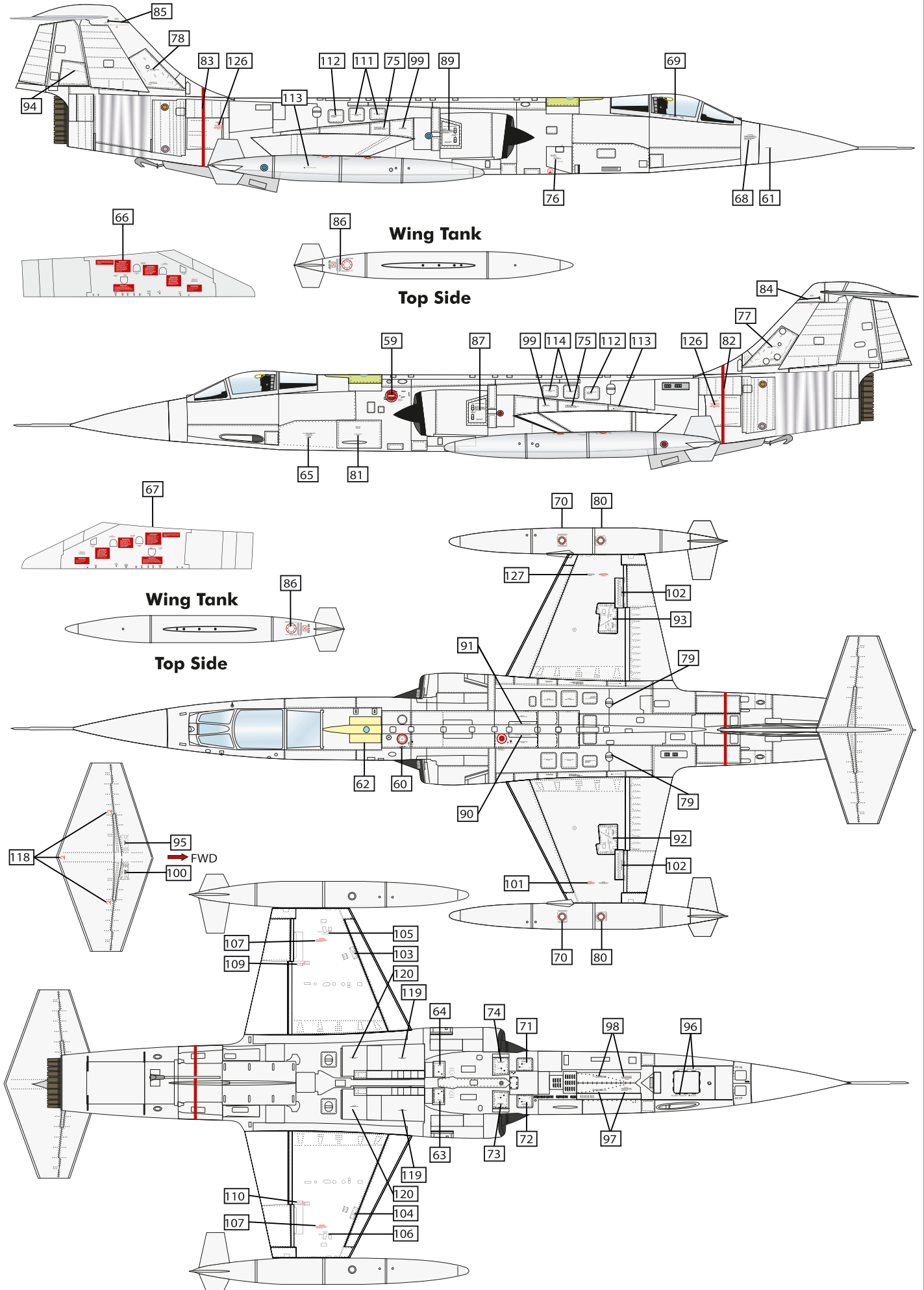

DÉCOUVREZ LE MONDE DES PEINTURES ACRYLIQUES HELLER !

DISCOVER THE WORLD OF HELLER ACRYLIC PAINTS!
ENTDECKEN SIE DIE WELT DER HELLER ACRYL-FARBEN!

NEW



- FACILE À UTILISER
- DILUABLE À L'EAU
- POTS DE PEINTURE STABLES
- BOUCHON À VIS SÉCURISÉ

- EASY TO USE
- DILUTABLE WITH WATER
- STABLE PAINT CANS
- SECURE SCREW CAP

- EINFACHE ANWENDUNG
- MIT WASSER VERDÜNNBAR
- STANDFESTE FARBDOSEN
- SICHERER SCHRAUBVERSCHLUSS

VISITEZ-NOUS EN LIGNE !

VISIT US DIGITALLY!
BESUCHEN SIE UNS DIGITAL!

 www.heller.fr

 [instagram.com/heller.fr](https://www.instagram.com/heller.fr)

 [facebook.com/heller.fr](https://www.facebook.com/heller.fr)



Choisissez l'article désiré et téléchargez la notice de montage.

Choose your desired article and download the instructions.

Wählen Sie den gewünschten Artikel und laden Sie die Anleitung herunter.

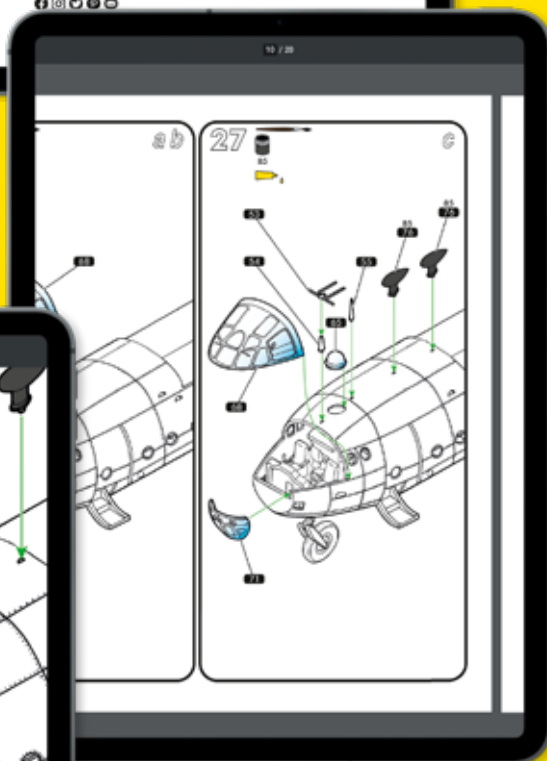

Download all instructions!

Grossissement des instructions pour une vue détaillée.



Enlarge the instructions for a more detailed view.

Vergrößern Sie die Anleitung für eine detailliertere Ansicht.

Service consommateurs
Pour toute demande de SAV, connectez-vous sur notre site www.heller.fr.

Customer Service
For after-sales service requests, please contact us through our website www.heller.fr.

Endverbraucherservice
Bitte besuchen Sie uns auf www.heller.fr für alle Ersatzteilanfragen.

Heller Hobby GmbH
Erlenbacher Str. 3 • 42477 Radevormwald • GERMANY
 +49 (0) 2195-92773-0  info@heller.fr