

# CITROËN 11 CV

80159

## Français

La traction avant six cylindres apparait en 1938 au Grand Palais. Surnommée la «Reine de la Route», elle séduit l'Armée allemande et la Résistance, les truands et la police par sa solidité, sa puissance et son standing. Elle sera produite jusqu'en 1955. En 1980, elle se paiera le luxe de participer au second "Paris Dakar" sous les couleurs de HELLER.

## English

The 6 cylinder Traction Avant appeared at the Grand Palais in 1938. Known as the «Reine de la Route» (Queen of the Road), it won over both the German army and the French Resistance, the criminal classes and the police by its solidity, power and prestige.

## Deutsch

Die «Traction Avant» mit sechs Zylindern wird 1938 im Grand Palais in Paris vorgestellt. «Königin der Straße» genannt, überzeugt sie die deutsche Armee und die Résistance, die Gangster und die Polizei gleichermaßen durch ihre Robustheit, ihre Leistungsfähigkeit und ihren Luxus.

## Español

El «Traction Avant» (tracción delantera) seis cilindros apareció en 1938 en el Grand Palais. Apodado la «Rey de la Carretera», sedujo al Ejército Alemán y a la Resistencia, a los truhanes y a la policía por su solidez, su potencia y su standing.

## Italiano

La Trazione anteriore 6 cilindri ha fatto la sua apparizione al Gran Palazzo nel 1938. Soprannominata la «Regina della Strada», la trazione anteriore seduce l'esercito tedesco, la resistenza, i gangster e la polizia, per la sua solidità, la sua resistenza ed il suo standing.

## Nederlands

De zes cilinder «Traction Avant», wordt voor het eerst gepresenteerd in het Grand Palais in 1938. De wagen die de bijnaam «Koningin van de Weg» krijgt, wordt zowel gebruikt door het Duitse Leger, het Verzet, de bandieten, als door de politie, dankzij de degelijke constructie, het vermogen en zijn klasse.

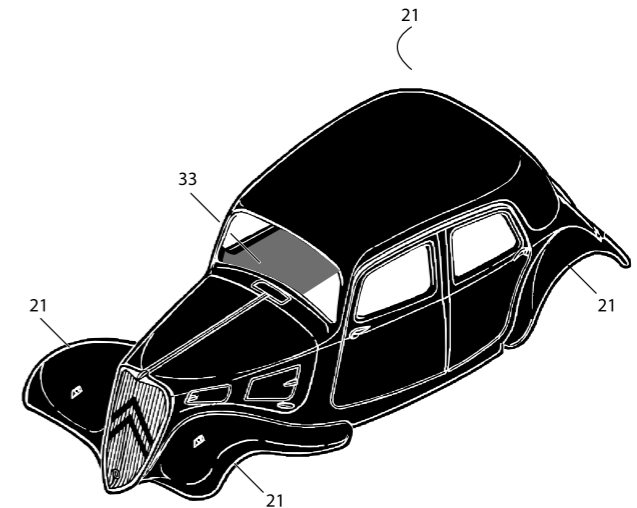
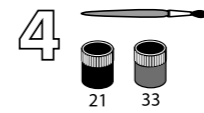
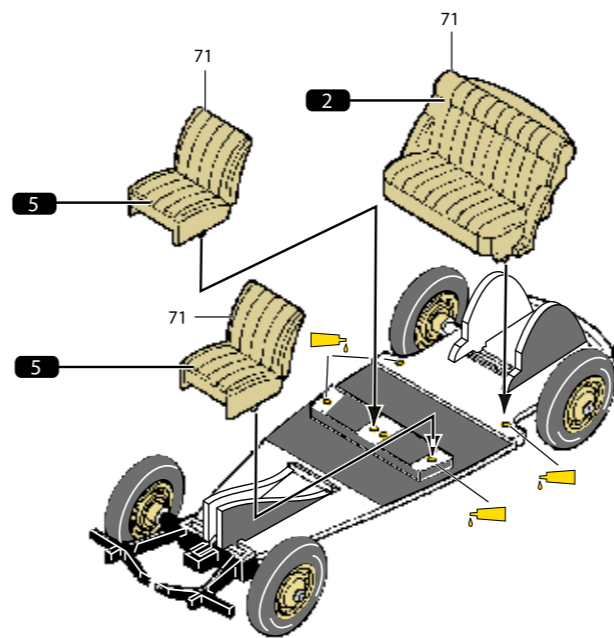
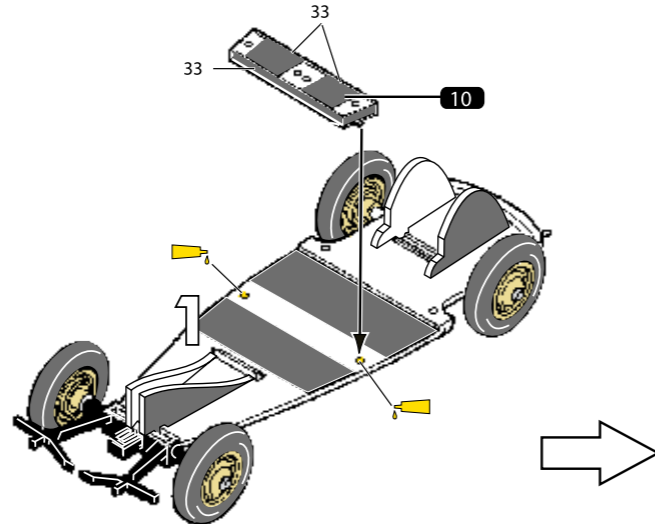
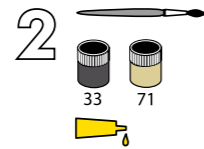
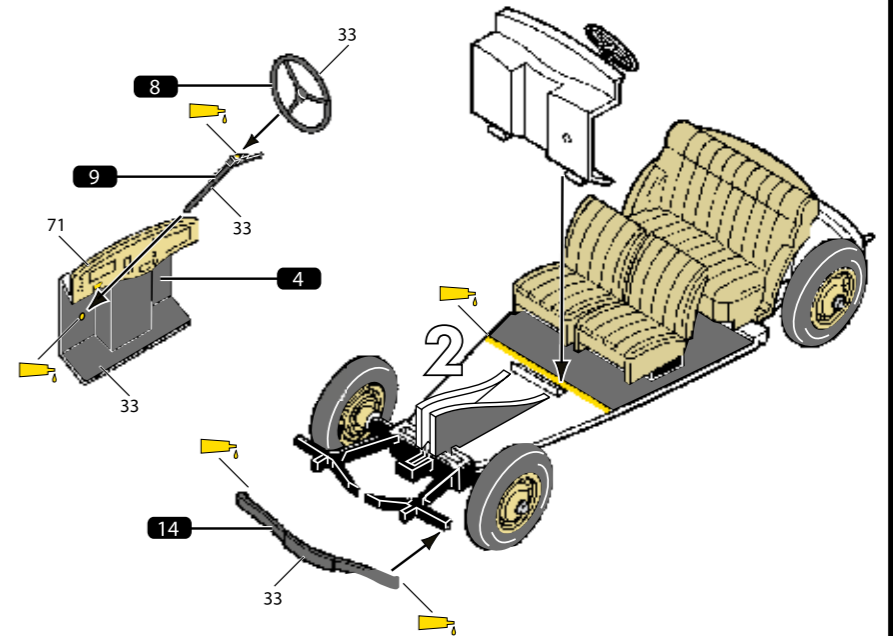
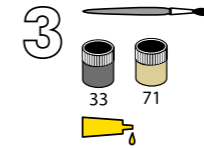
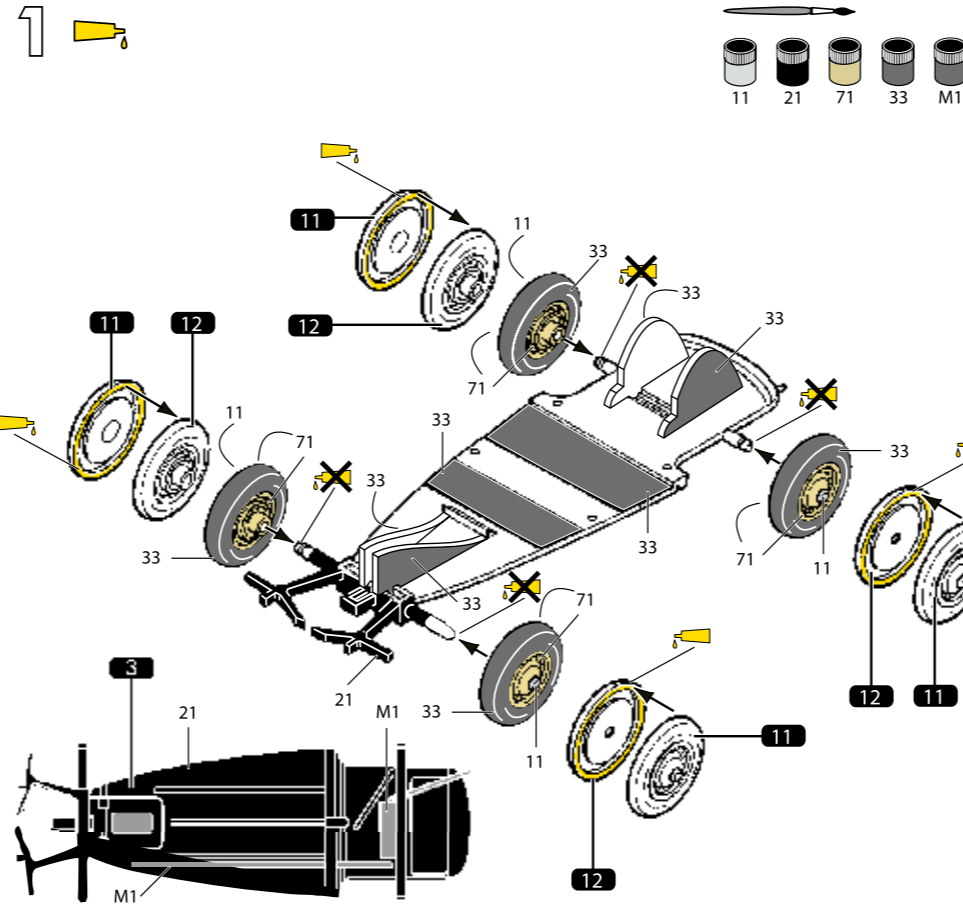
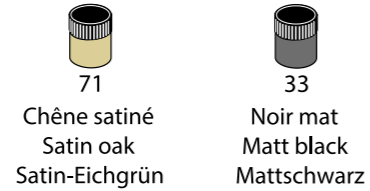
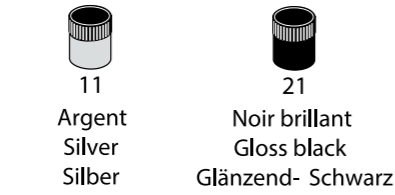

80159-176

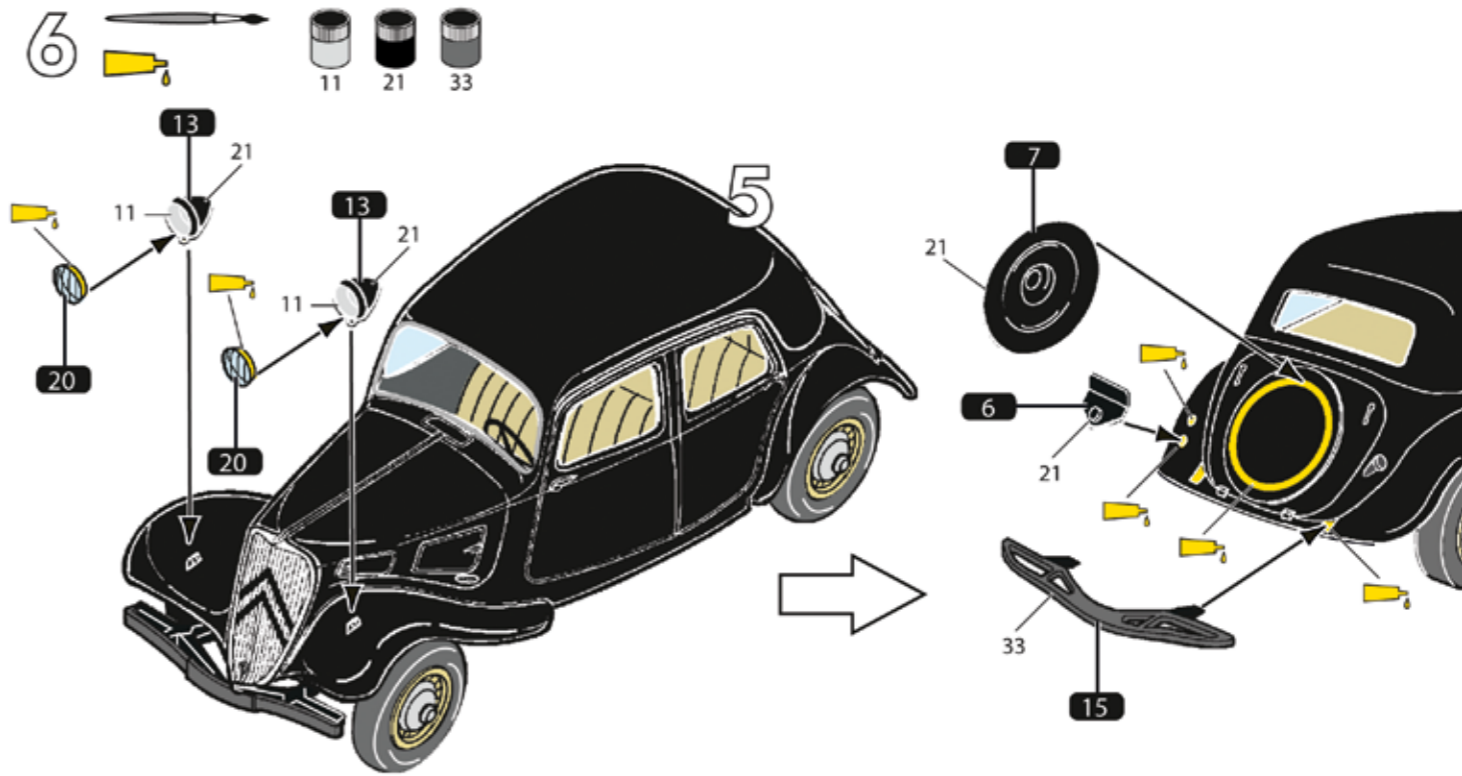
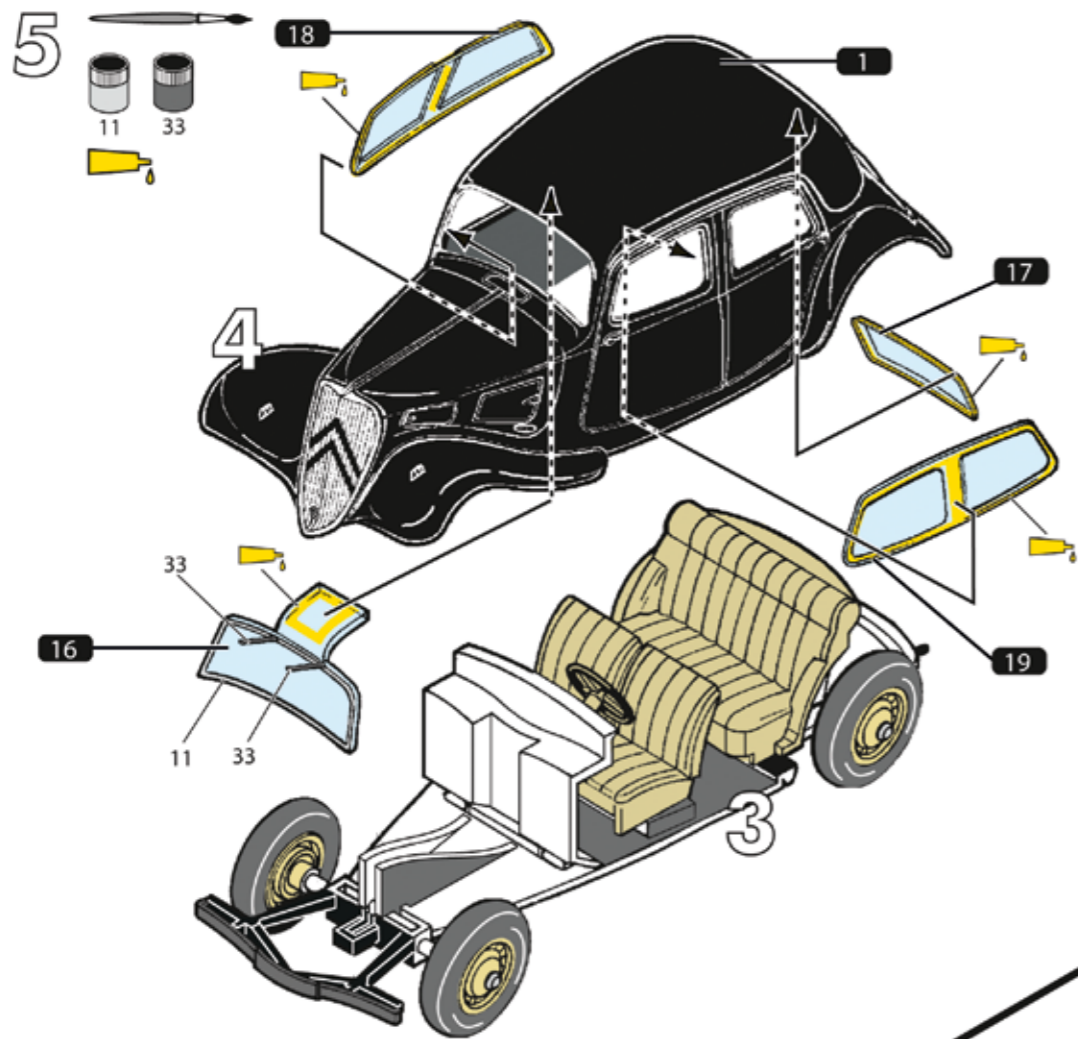

CITROEN 11 CV "Légère"

