

# Heller

# PANHARD 178 AMD 35

## 30325



## Français

### Véhicule blindé français de la Seconde Guerre mondiale.

La Panhard 178 (désignation officielle Auto-Mitrailleuse de Découverte (AMD) Panhard modèle 1935, numéro de projet interne 178) était un véhicule blindé de reconnaissance à quatre roues motrices conçu pour l'armée française et développé par la société Panhard avant la Seconde Guerre mondiale.

Elle était conçue pour un équipage de quatre hommes et était équipée d'un canon de 25 mm et d'une mitrailleuse de 7,5 mm .

C'est le véhicule blindé français le plus connu et le plus construit, comme véhicule de reconnaissance.

La production en série de la Panhard 178 a commencé en 1934, elle avait un moteur arrière et quatre roues motrices, et . 551 véhicules ont été produits jusqu'en 1940.

Elle participe aux combats de l'armée française au printemps 1940 et, bien utilisée, elle est capable de résister aux chars allemands et aux véhicules blindés de toutes sortes.

Après l'armistice de Compiègne en 1940, environ 200 de ces véhicules ont été capturés par la Wehrmacht allemande, repris et utilisés sous le nom de Pz.späh.204 (f) (Panzerspähwagen P204 (f)).

Après la guerre, une version révisée a été produite sous le nom de Panhard 178B.

## English

### French armoured vehicle of the Second World War.

The Panhard 178 (official designation Auto-Mitrailleuse de Découverte (AMD) Panhard model 1935, internal project number 178) was a four-wheel drive armoured reconnaissance vehicle designed for the French Army and developed by the Panhard company before the Second World War.

Designed for a crew of four, it was equipped with a 25mm cannon and a 7.5mm machine gun.

It was the best known and most built French armoured vehicle developed by the Panhard company as a reconnaissance vehicle.

Series production of the Panhard 178 began in 1934, it had a rear engine and four-wheel drive, and 551 cars were produced by 1940.

It took part in the battles fought by the French army in the spring of 1940 and, when well used, was able to withstand German tanks and armoured vehicles of all kinds.

After the Armistice of Compiègne in 1940, about 200 of these vehicles were captured by the German Wehrmacht and taken over and used under the name Pz.späh.204 (f) (Panzerspähwagen P204 (f)). After the war, a revised version was produced as the Panhard 178B.

## Deutsch

### Französisches Panzerfahrzeug des Zweiten Weltkrieges

Der Panhard 178 (offizielle Bezeichnung Auto-Mitrailleuse de Découverte (AMD) Panhard Modell 1935, interne Projektnummer 178) war ein gepanzertes, allradgetriebenes Aufklärungsfahrzeug für die französische Armee, das vor dem Zweiten Weltkrieg von der Firma Panhard entwickelt wurde.

Ausgerüstet mit einer 25 mm Kanone und einem 7,5 mm Maschinengewehr war er für eine vierköpfige Besatzung ausgelegt.

Er war der bekannteste und am häufigsten gebaute französische Panzerwagen, der von der Firma Panhard als Aufklärungsfahrzeug entwickelt wurde.

Die Serienproduktion des Panhard 178 begann 1934, er hatte Heckmotor und Allradantrieb, bis 1940 entstanden 551 Fahrzeuge.

Er nahm an den Kämpfen im Frühjahr 1940 für die französische Armee teil und konnte bei richtigem Einsatz den deutschen Panzern und Panzerwagen aller Typen widerstehen.

Nach dem Waffenstillstand von Compiègne 1940 wurden ca. über 200 dieser Fahrzeuge von der deutschen Wehrmacht erbeutet und unter der Bezeichnung Pz.späh.204 (f) (Panzerspähwagen P204 (f)) übernommen und eingesetzt. Nach Kriegsende wurde eine überarbeitete Version als Panhard 178B produziert.

## Español

### Vehículo blindado francés de la Segunda Guerra Mundial.

La Panhard 178 (designación oficial Auto-Ametralladora de Descubrimiento (AMD) Panhard modelo 1935, número de proyecto interno 178) era un vehículo blindado de reconocimiento con tracción a las cuatro ruedas diseñado para el ejército francés y desarrollado por la empresa Panhard antes de la Segunda Guerra Mundial.

Estaba diseñada para una dotación de cuatro hombres y estaba equipada con un cañón de 25 mm y una ametralladora de 7,5 mm.

Es el vehículo blindado francés más conocido y más construido como vehículo de reconocimiento.

La producción en serie del Panhard 178 comenzó en 1934: tenía un motor trasero, tracción a las cuatro ruedas y se produjeron 551 unidades hasta 1940.

Participó en los combates del ejército francés en la primavera de 1940 y, bien utilizada, fue capaz de resistir a los tanques alemanes y a los vehículos blindados de todo tipo.

Después del armisticio de Compiègne en 1940, alrededor de 200 de estos vehículos fueron capturados por la Wehrmacht alemana, recuperados y utilizados con el nombre de Pz.späh.204 (f) (Panzerspähwagen P204 (f)).

Después de la guerra, se produjo una versión revisada con el nombre de Panhard 178B.

## Italiano

### Veicolo corazzato francese della Seconda Guerra mondiale.

Il Panhard 178 (denominazione ufficiale Auto-Mitrailleuse de Découverte (AMD) Panhard modello 1935, numero di progetto interno 178) era un veicolo corazzato da ricognizione a quattro ruote motrici progettato per l'esercito francese e sviluppato dalla società Panhard prima della Seconda Guerra mondiale.

Era progettato per un equipaggio di quattro uomini ed era dotato di un cannone da 25 mm e di una mitragliatrice da 7,5 mm.

È il veicolo corazzato francese più conosciuto e costruito come veicolo da ricognizione.

La produzione in serie del Panhard 178 è iniziata nel 1934 e disponeva di un motore posteriore e di quattro ruote motrici. Fino al 1940 ne sono stati prodotti 551 esemplari.

Ha partecipato ai combattimenti dell'esercito francese nella primavera del 1940 e, quando ben utilizzato, è stato in grado di resistere ai carri armati tedeschi e ai veicoli corazzati di ogni tipo.

Dopo l'armistizio di Compiègne nel 1940, la Wehrmacht tedesca ne ha presi circa 200 e li ha utilizzati con il nome di Pz.späh.204 (f) (Panzerspähwagen P204 (f)).

Nel dopoguerra ne è stata prodotta una versione rivista con il nome di Panhard 178B.

## Nederlands

### Frans pantservoertuig uit de Tweede Wereldoorlog.

De Panhard 178 (officiële aanduiding Auto-Mitrailleuse de Découverte (AMD) Panhard model 1935, intern projectnummer 178) was een vierwielangedreven gepantserd verkenningsvoertuig ontworpen voor het Franse leger en ontwikkeld door het bedrijf Panhard voor de Tweede Wereldoorlog.

Het was ontworpen voor een bemanning van vier man en was uitgerust met een 25 mm kanon en een 7,5 mm machinegeweer.

Het is het bekendste en meest gebouwde Franse pantservoertuig, dat wordt gebruikt als verkenningsvoertuig.

De serieproductie van de Panhard 178 begon in 1934, met een motor achterin en vierwielaandrijving. Tot 1940 werden er 551 voertuigen geproduceerd. Het nam deel aan de gevechten van het Franse leger in de lente van 1940 en was, goed gebruikt, in staat om weerstand te bieden aan Duitse tanks en allerlei soorten pantservoertuigen.

Na de wapenstilstand van Compiègne in 1940 werden ongeveer 200 van deze voertuigen veroverd door de Duitse Wehrmacht, teruggenomen en gebruikt onder de naam Pz.späh.204 (f) (Panzerspähwagen P204 (f)).

Na de oorlog werd een herziene versie geproduceerd onder de naam Panhard 178B.

1/35

PANHARD 178 AMD 35

30325



11

Argent métallique  
Silver Metallic  
Silber metallisch



12

Cuivre jaune métallique  
Copper Metallic  
Kupfer metallisch



33

Noir mat  
Black Matt  
Schwarz matt



34

Blanc mat  
White Matt  
Weiß matt



53

Gris métallique  
Gunmetal Metallic  
Grau metallisch



56

Aluminium métallique  
Aluminium Metallic  
Aluminium metallisch



85

Noir de charbon satiné  
Coal Black Satin  
Kohlenschwarz seidenmatt



86

Olive clair mat  
Light Olive Matt  
Olivgrün hell matt



91

Vert noir mat  
Black Green Matt  
Schwarzgrün matt



102

Vert armée mat  
Army Green Matt  
Armeegrün matt



110

Bois naturel mat  
Natural Wood Matt  
Naturholz matt



113

Rouille mat  
Rust Matt  
Rost matt



186

Brun mat  
Brown Matt  
Braun matt



M1

86 + 34

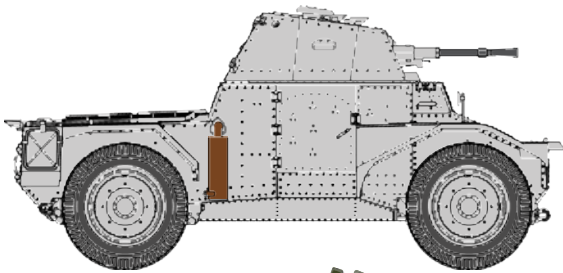

a

Véhicule blindé de reconnaissance Panhard 178 P 204(f) WH-622629 : 2<sup>e</sup> Bataillon de Reconnaissance, 2<sup>e</sup> Division blindée, front de l'Est, hiver 1941.

Armored reconnaissance vehicle Panhard 178 P 204(f) WH-622629: 2<sup>nd</sup> Reconnaissance Battalion, 2<sup>nd</sup> Armored Division, Eastern Front, Winter 1941.



b

Panhard 178 AMD 35 N° 91659: 1<sup>er</sup> DLM (Division Légère Mécanique), 6<sup>e</sup> Régiment de Cuirassiers, 1<sup>er</sup> Escadron, 1<sup>er</sup> peloton, Zuidweg (Hollande), mai 1940.

Panhard 178 AMD 35 No. 91659: 1<sup>st</sup> DLM (Division Légère Mécanique), 6<sup>th</sup> Cuirassiers Regiment, 1<sup>st</sup> Squadron, 1<sup>st</sup> Platoon, Zuidweg (Holland), May 1940.

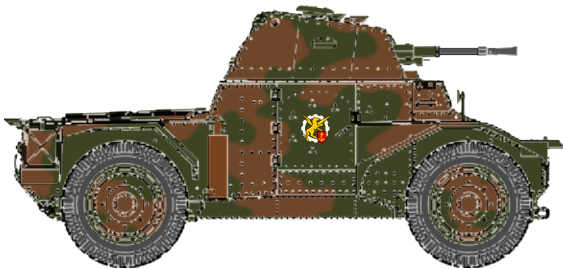

c

Panhard 178 AMD 35 N° M-7635: 3<sup>e</sup> DLC (Division Légère de Cavalerie), 3<sup>e</sup> RAM (Régiment d'Auto-Mitrailleuses), 1<sup>er</sup> Escadron, Luxembourg, mai 1940.

Panhard 178 AMD 35 N° M-7635: 3<sup>rd</sup> DLC (Division Légère de Cavalerie), 3<sup>rd</sup> RAM (Régiment d'Auto-Mitrailleuses), 1<sup>st</sup> Squadron, Luxembourg, May 1940.

- Si aucune teinte n'est spécifiée, peindre dans les couleurs de la version choisie. Se reporter aux pages 17 - 19 pour le détail du schéma de peinture.
- When no color is specified, paint the item with colors of chosen version. Refer to pages 17 - 19 for painting pattern.
- Wenn keine Farbe angegeben ist, Teile mit den Farben der gewählten Version bemalen. Beachten Sie die Seiten 17 - 19 für die Lackierung und Markierung.
- Cuando ningún color es especificado, pintarle con los colores del tema de la versión elegida. Vea las páginas 17 - 19 para obtener detalles de pintura.

2

Numéro de phase  
Step number  
Schrittnummer  
Número de fase

56

Référence de couleur  
Colour reference no  
Farbangabe  
Referencia de color

37

Numéro de pièce  
Part number  
Teilenummer  
Número de pieza

6

Numéro de decal  
Decal number  
Abziehbildnummer  
Número de calcomanía

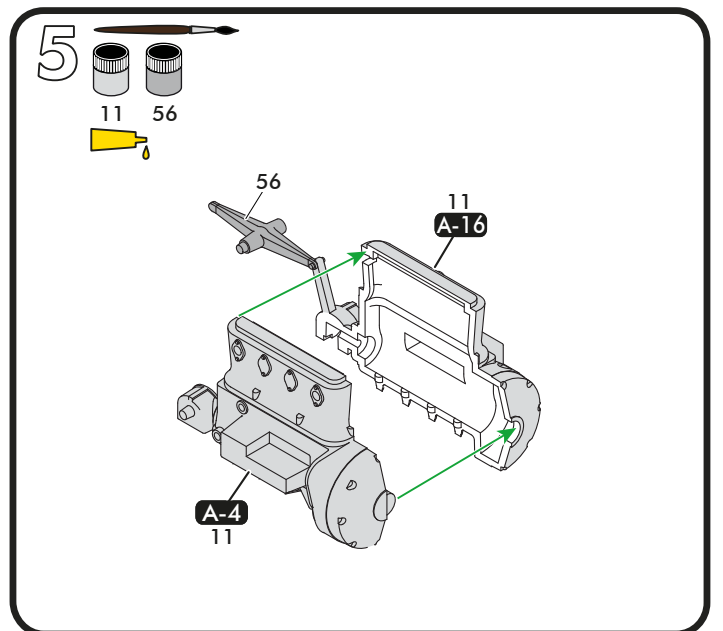
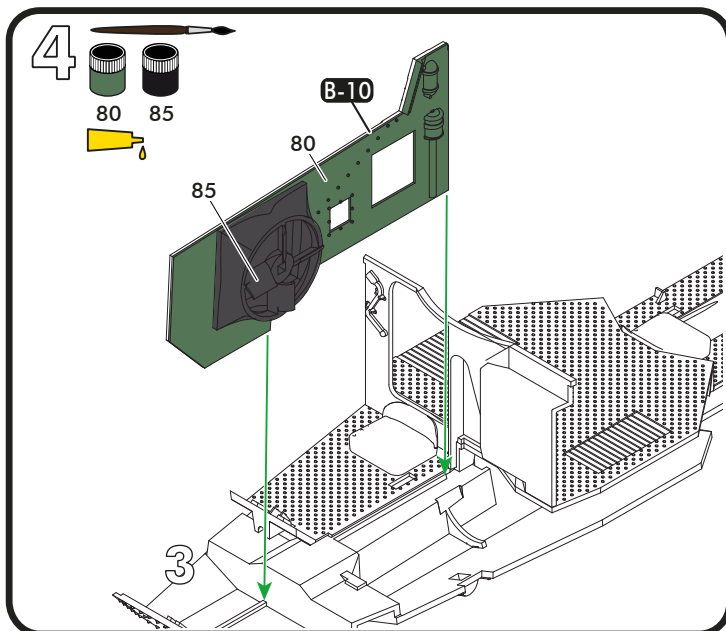
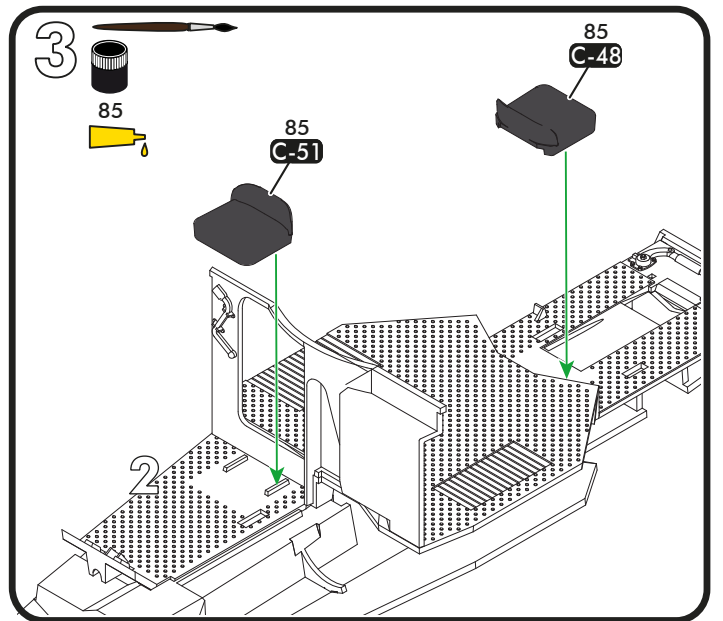
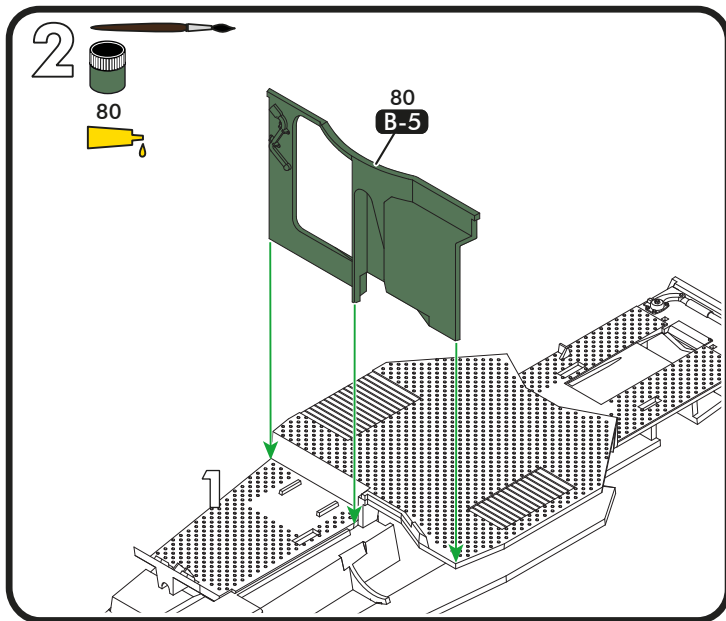
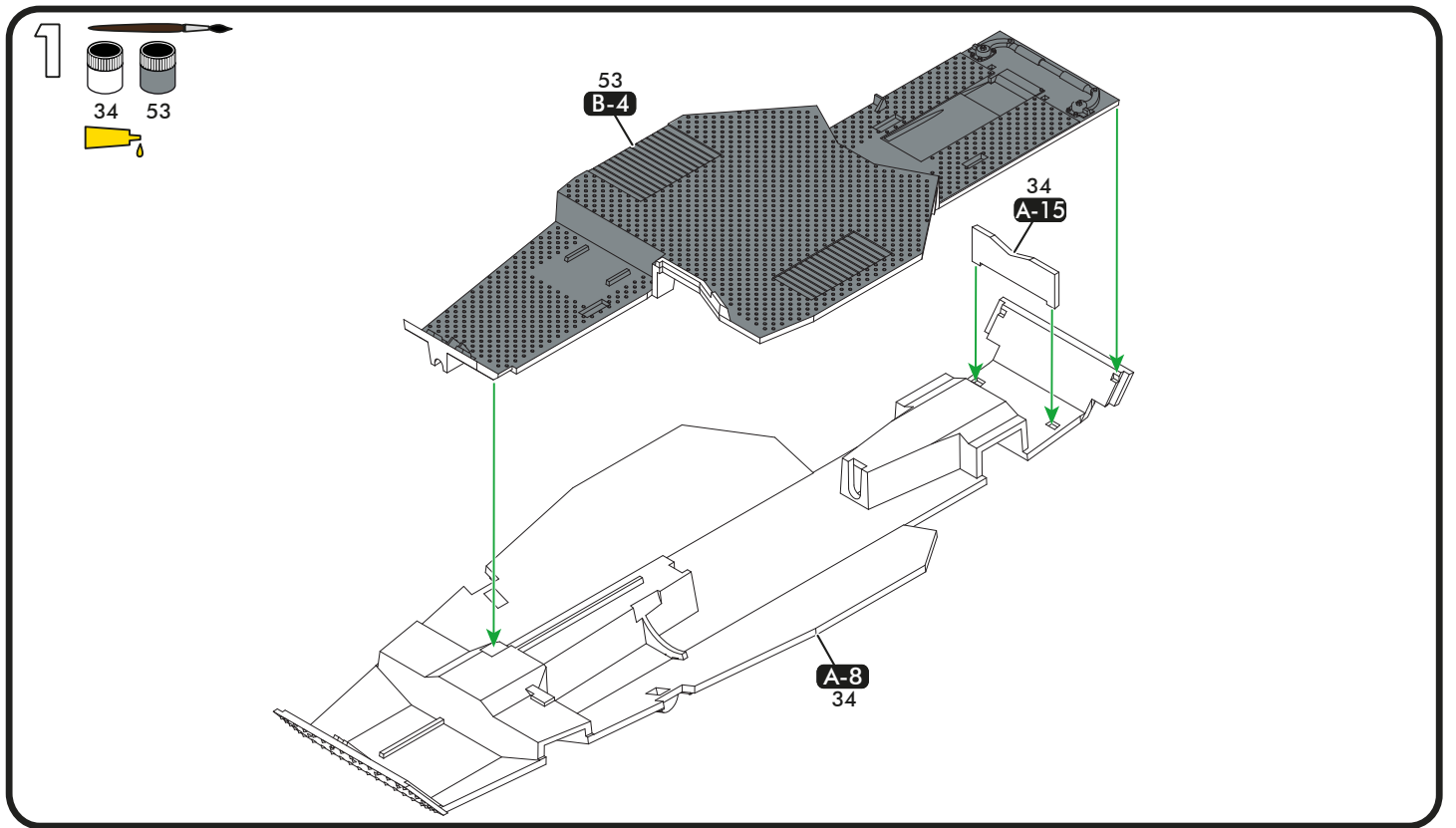

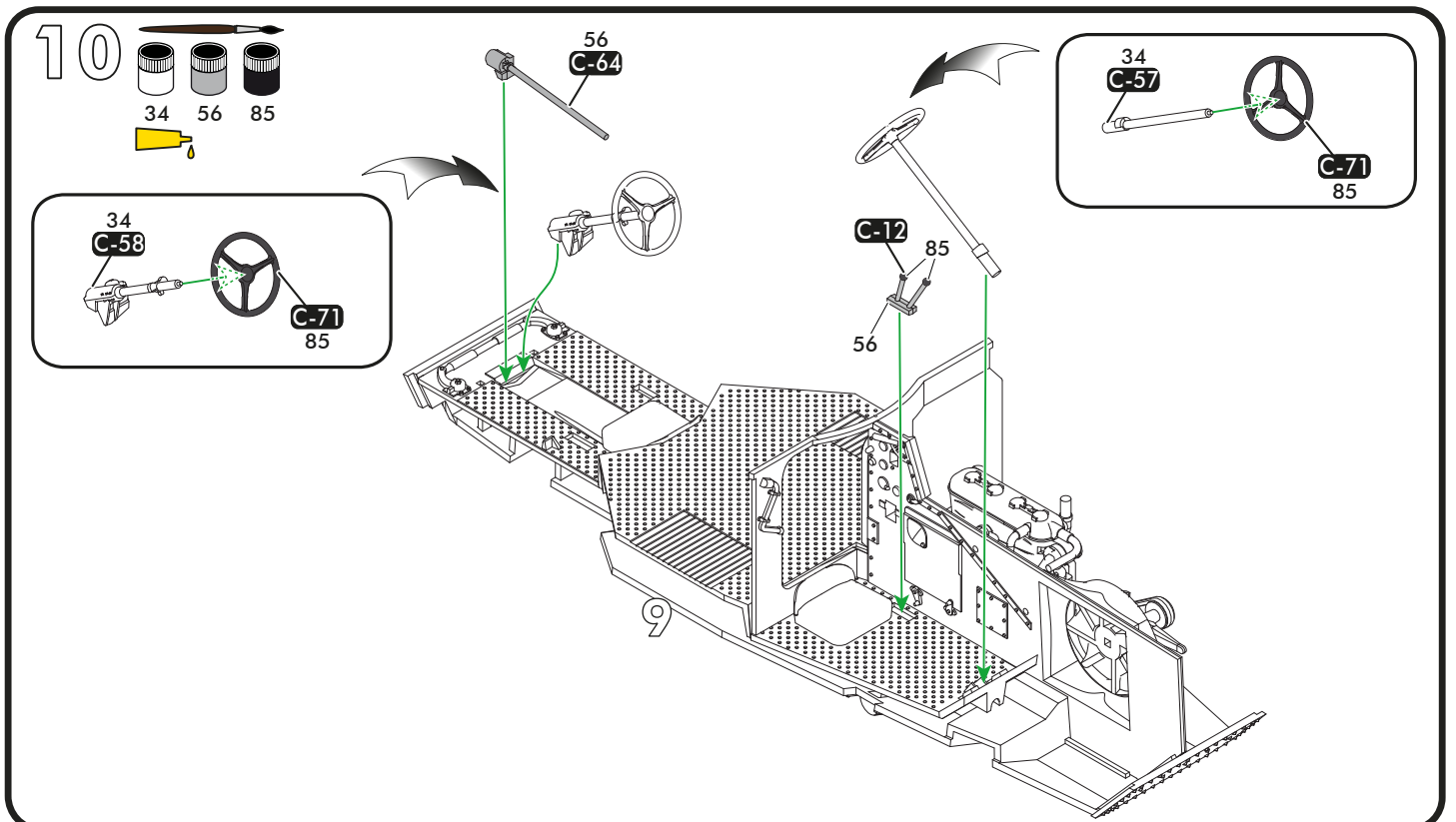
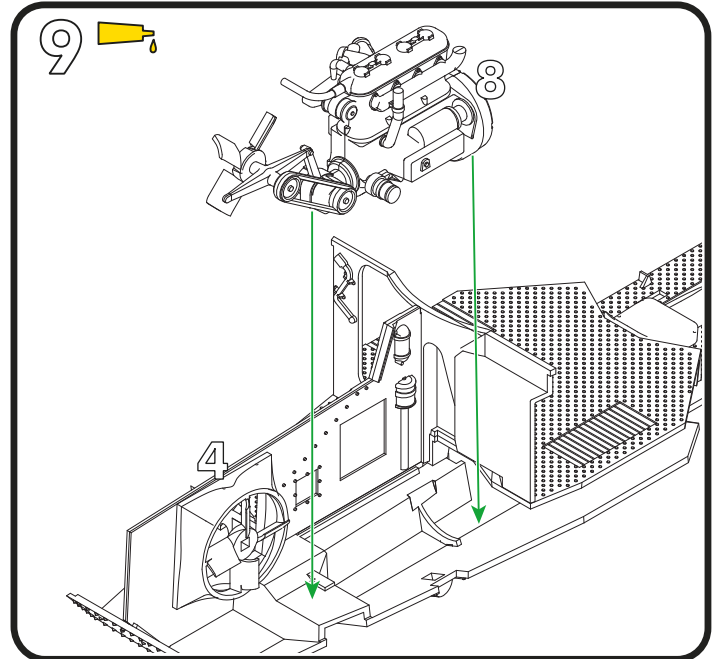
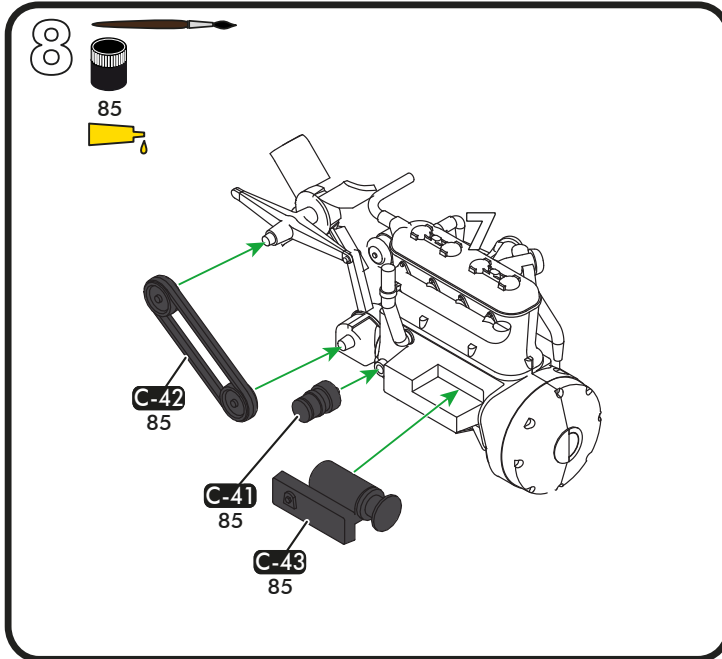
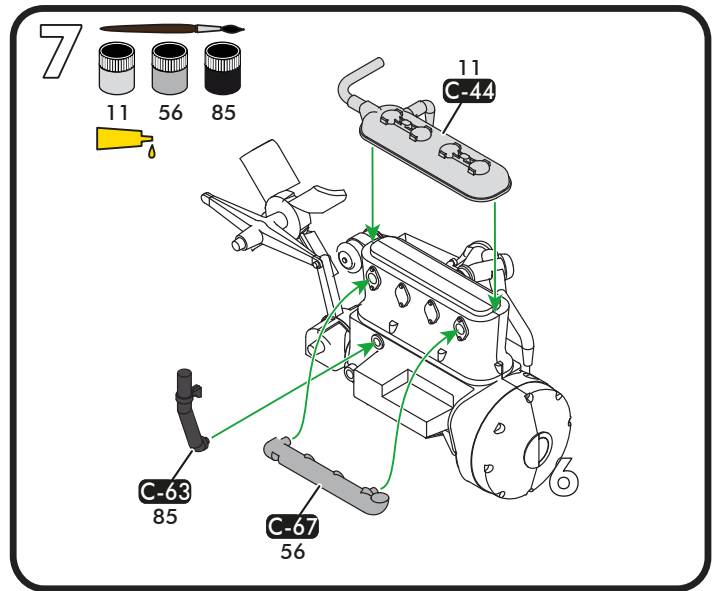
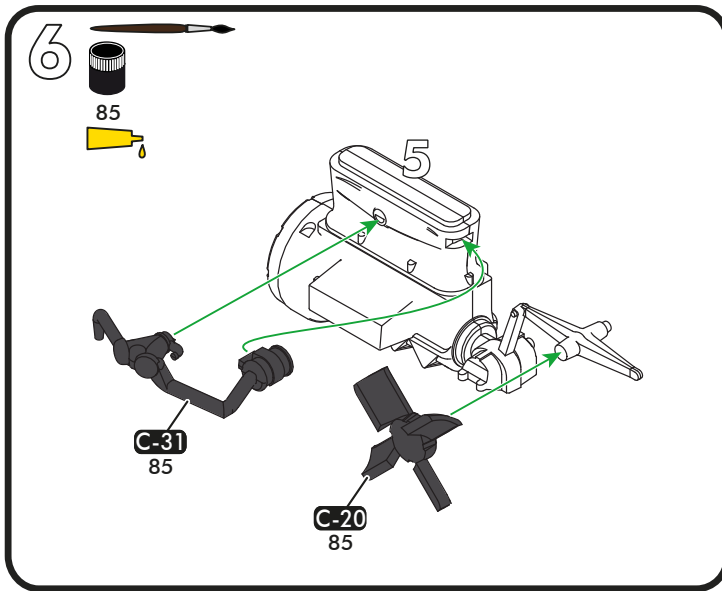

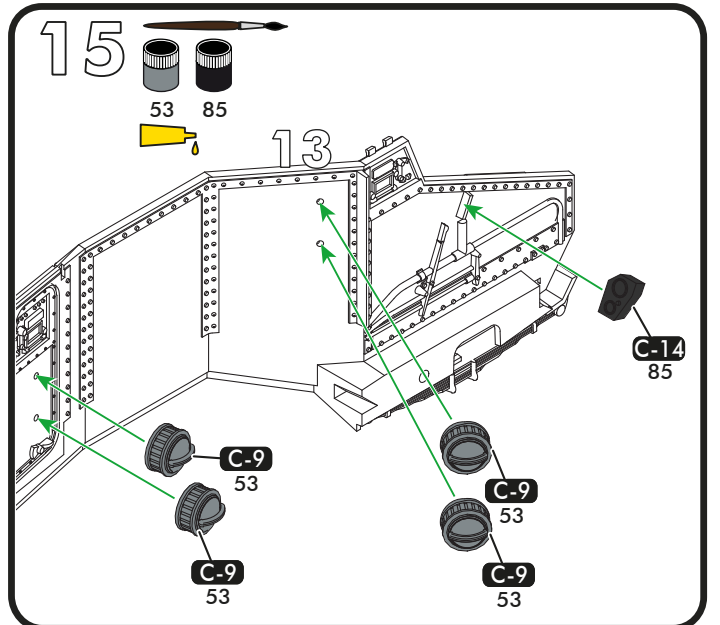
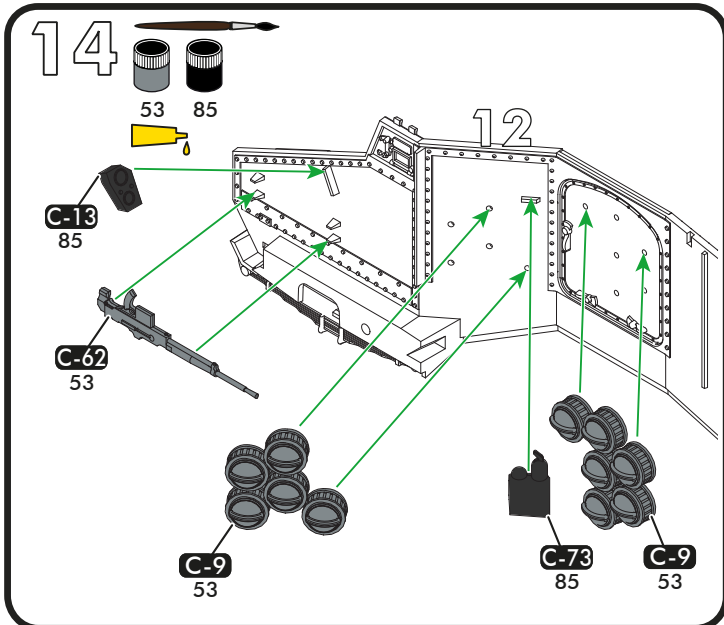
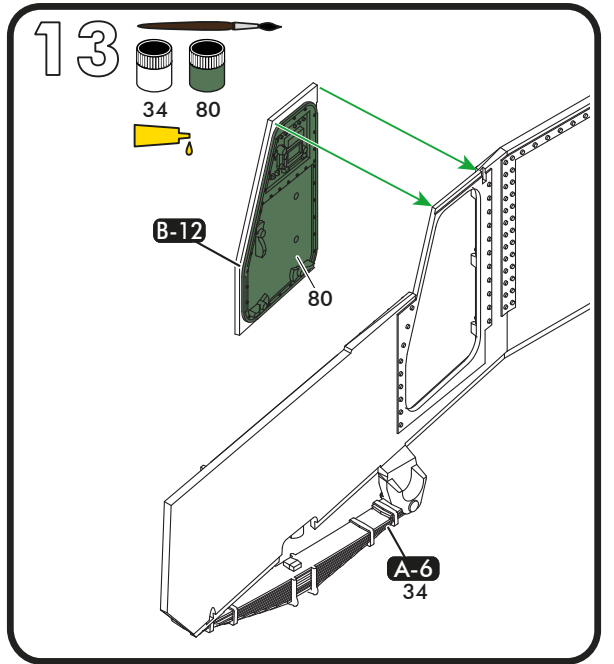
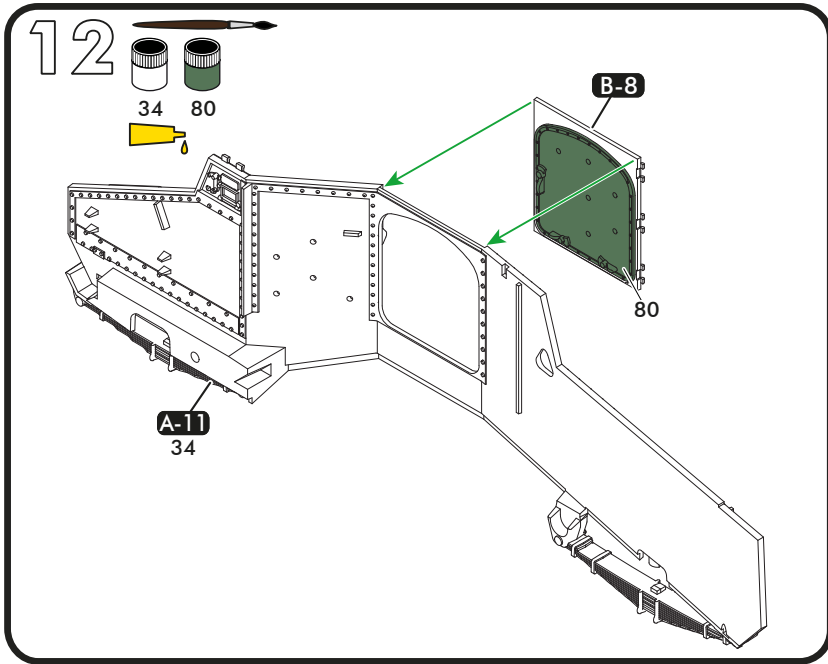
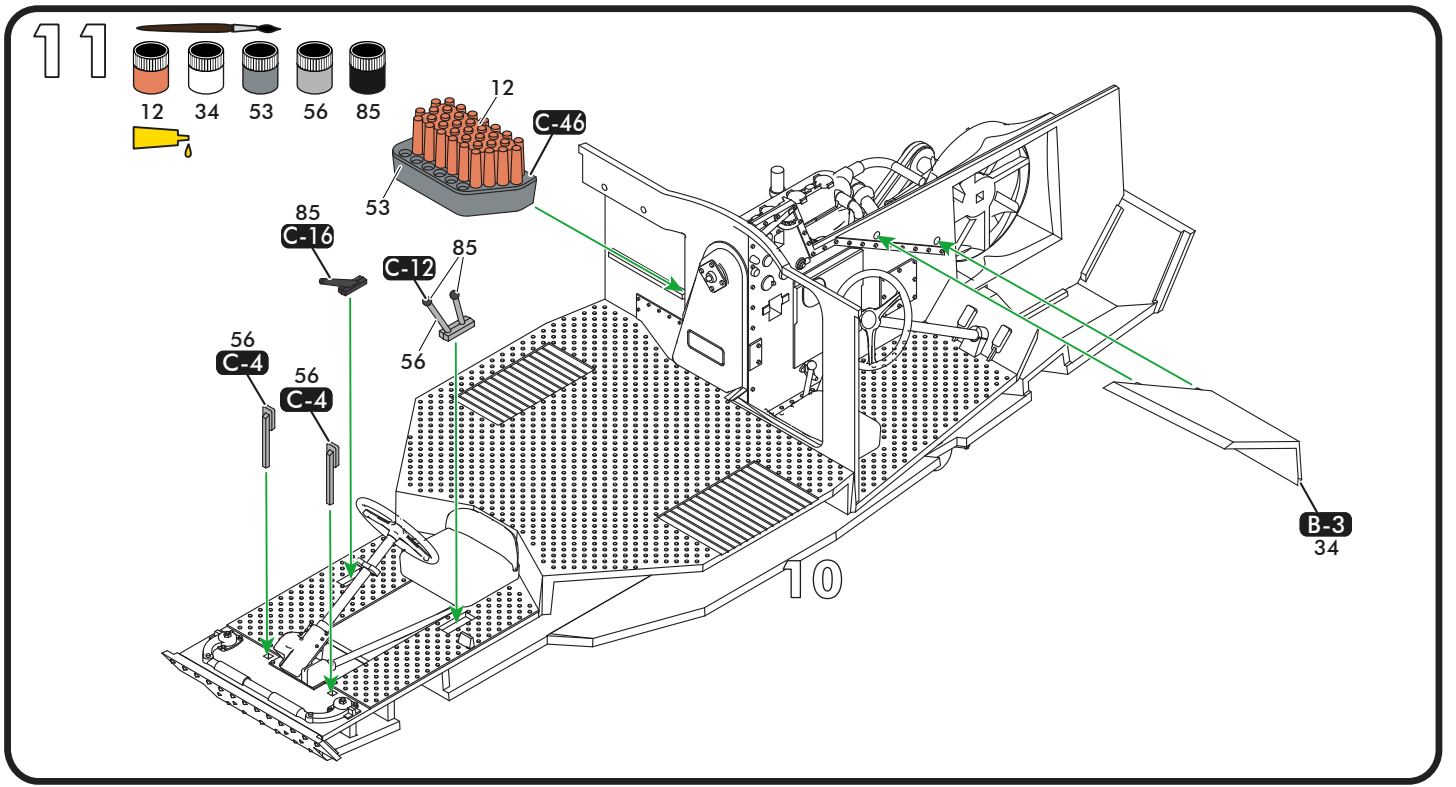

16 

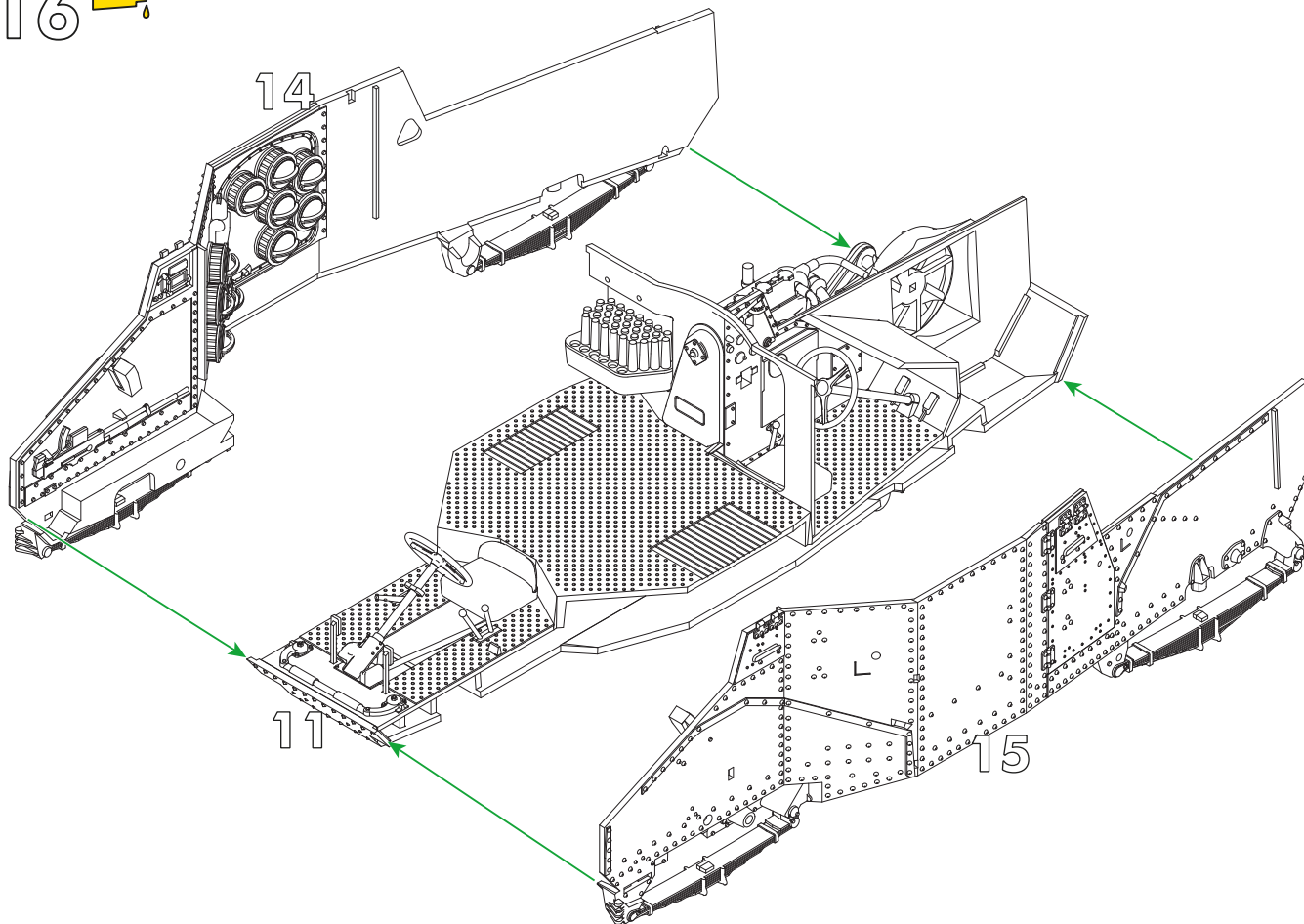

17 

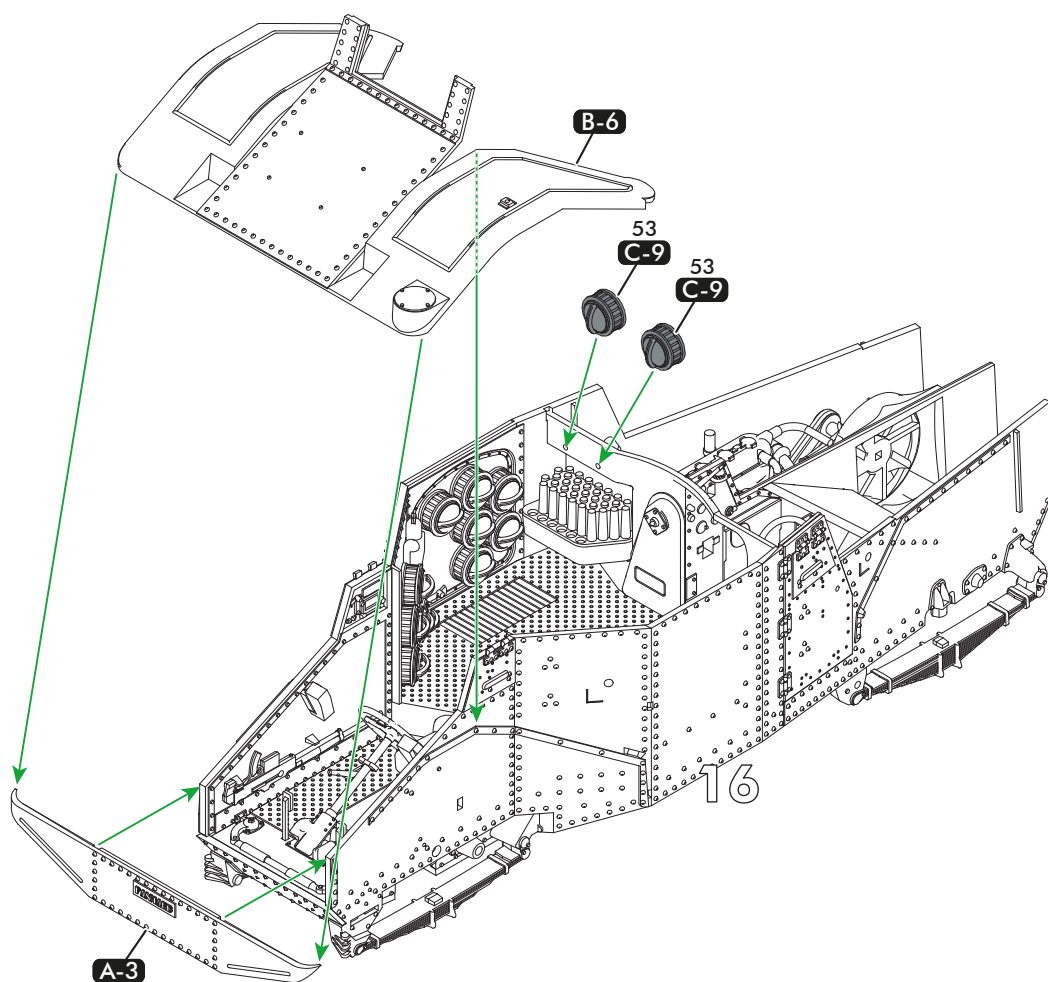
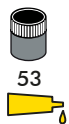

18

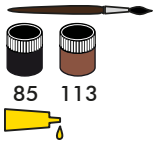

85 113

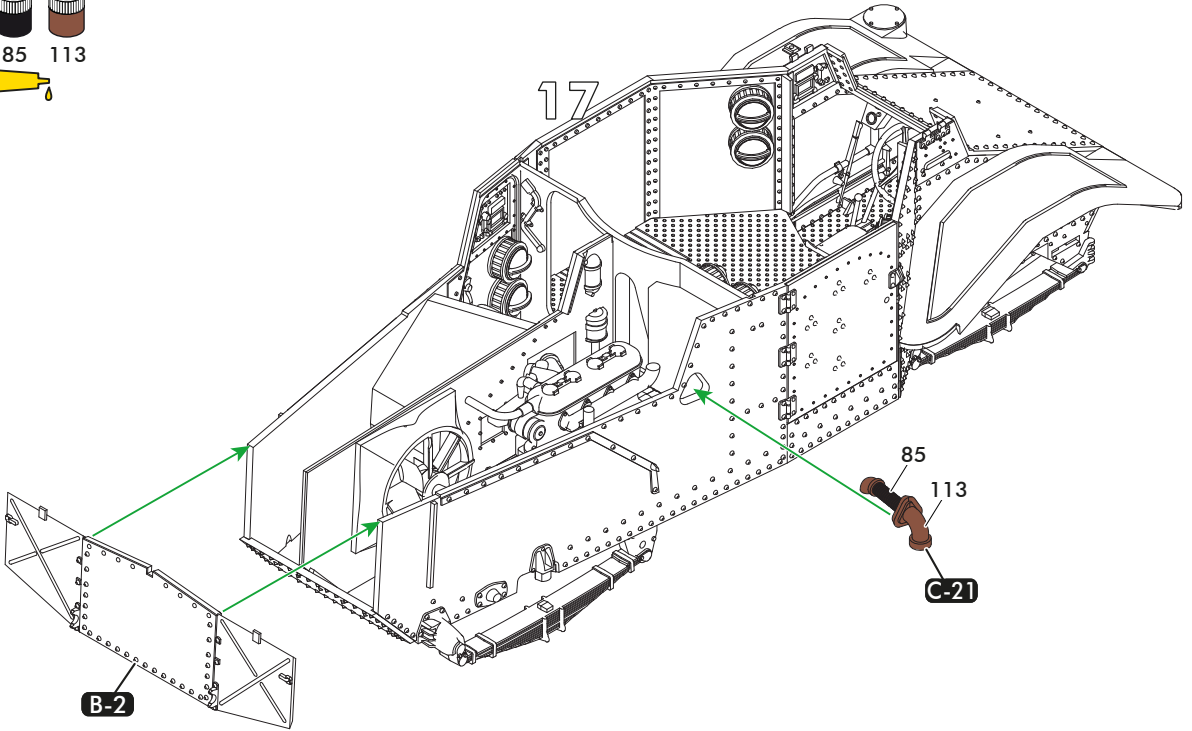

19

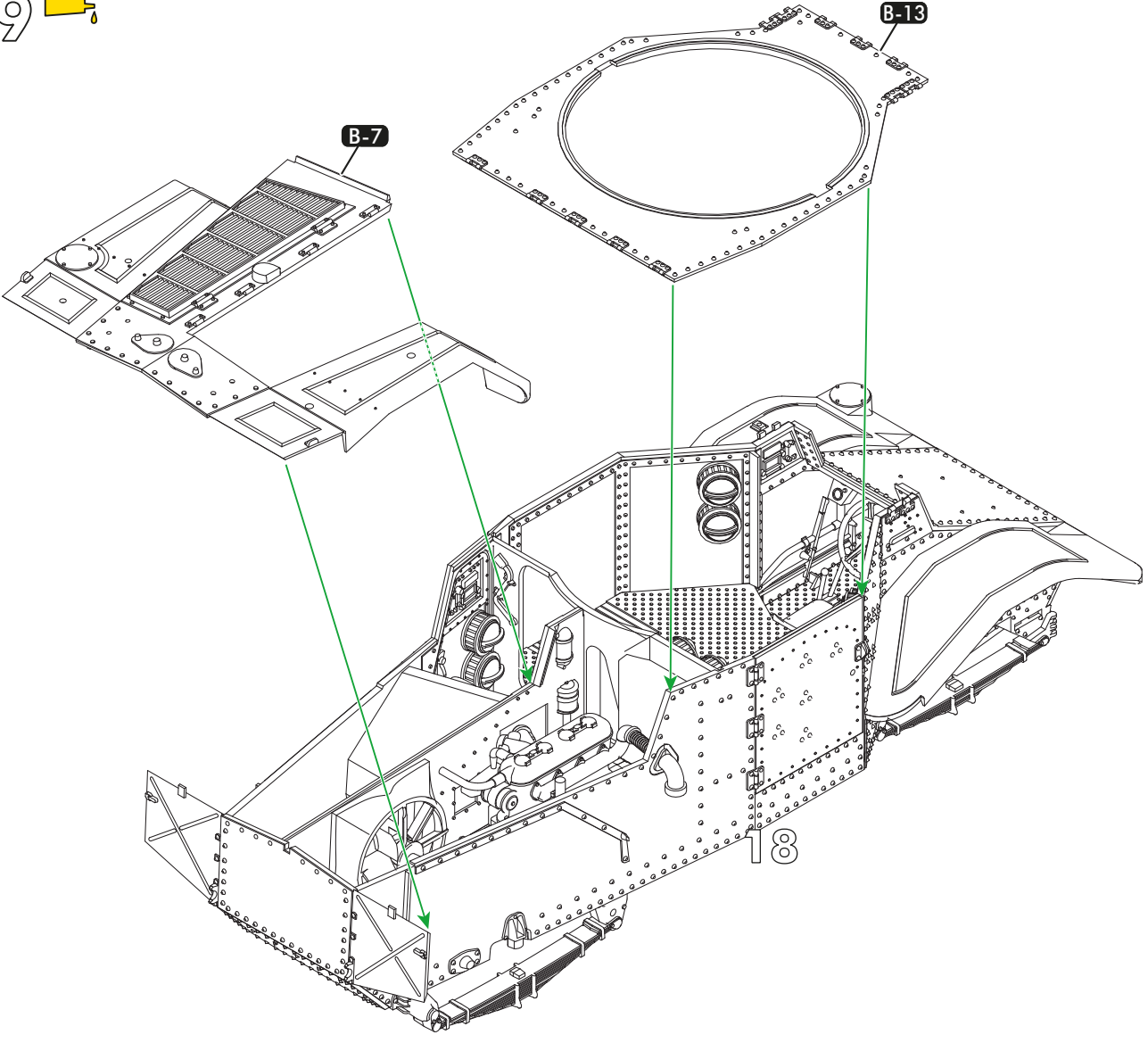



20 

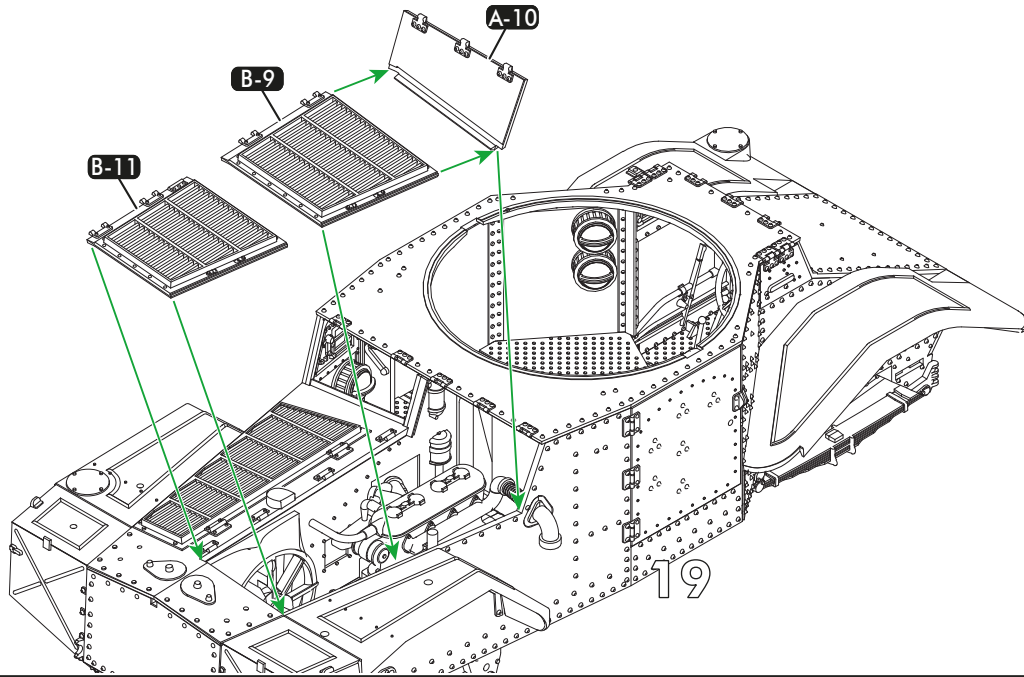

21 

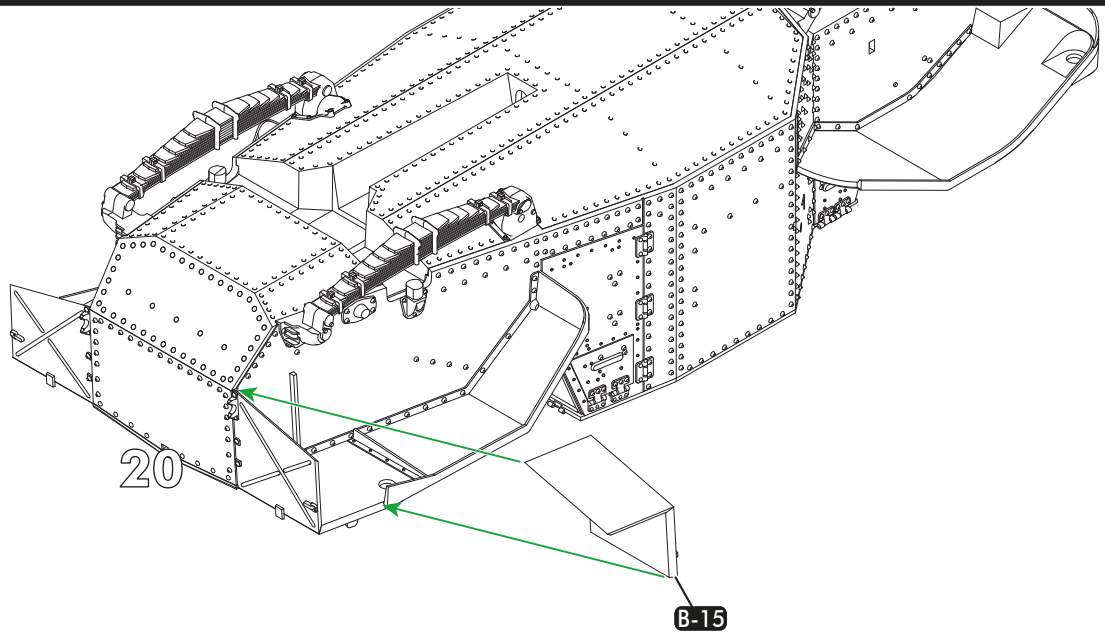

22 

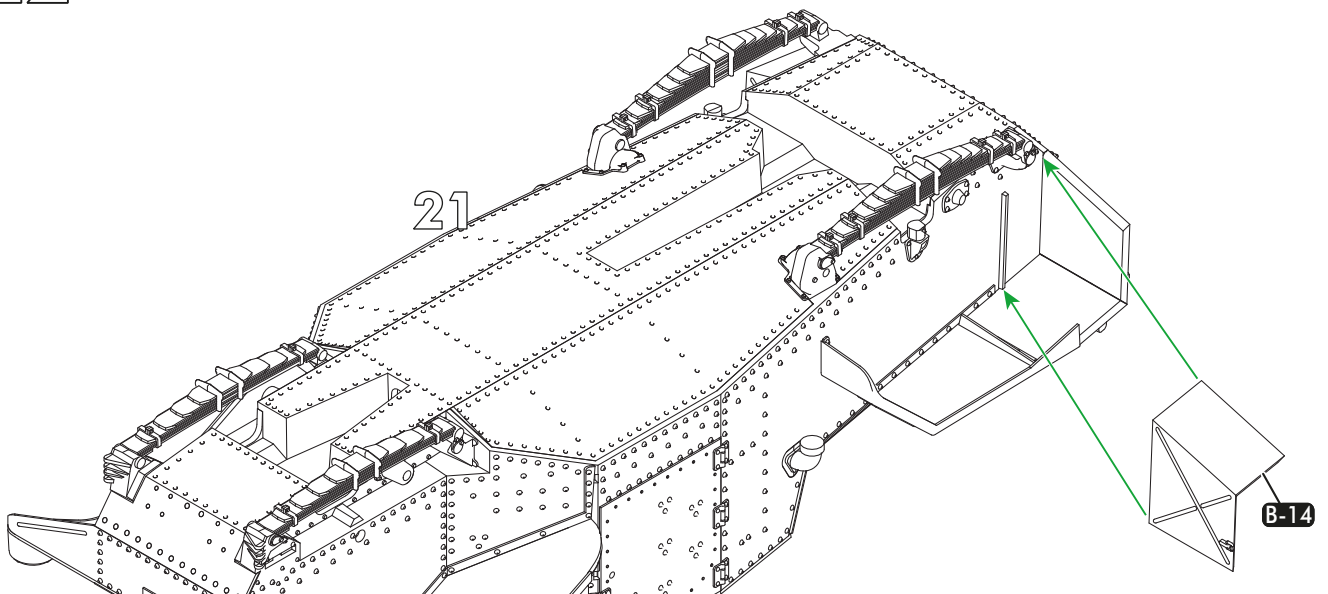

23 

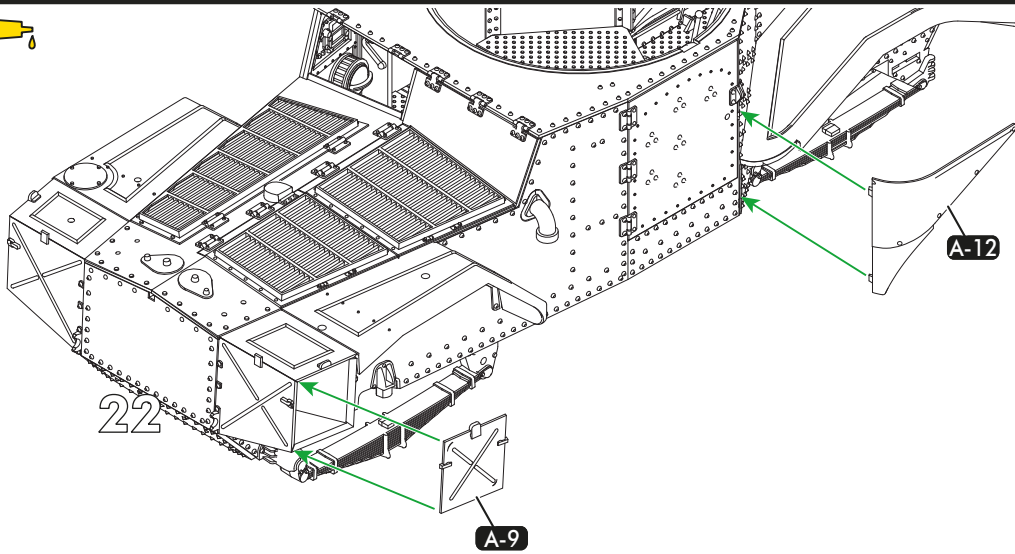

24 

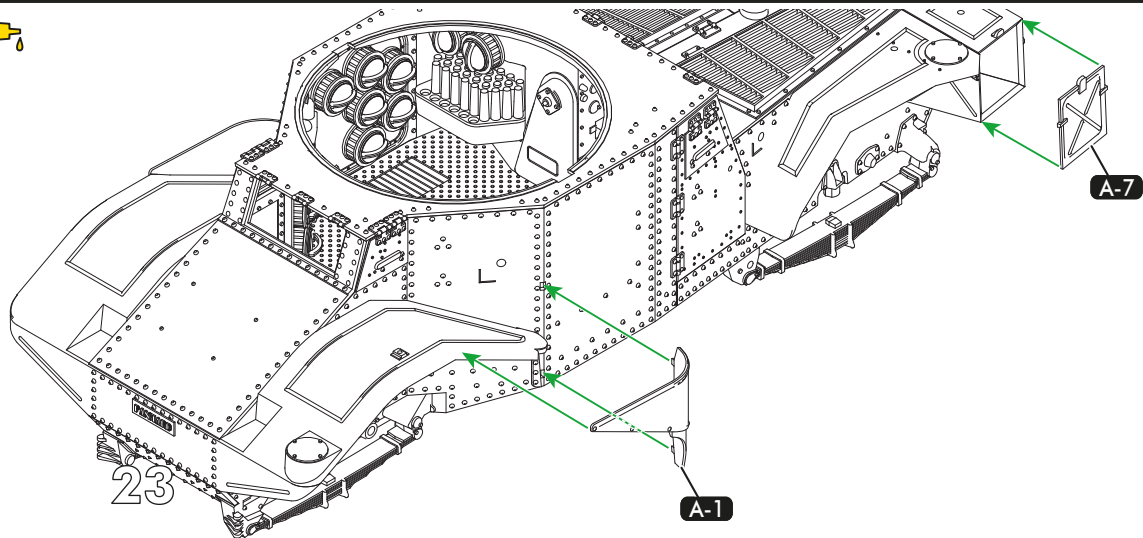

25 

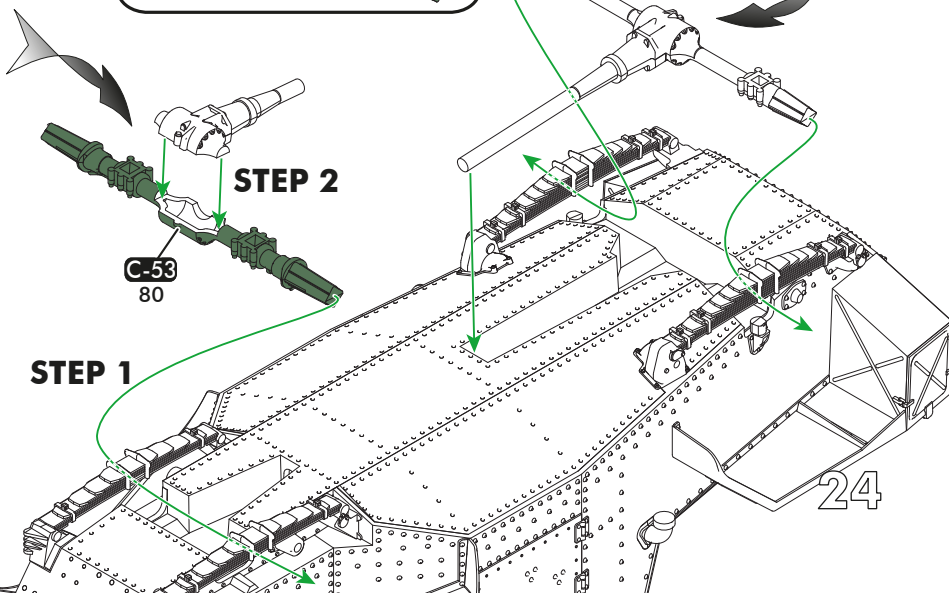
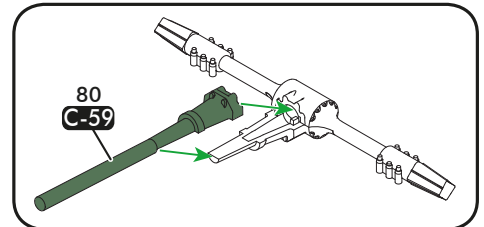
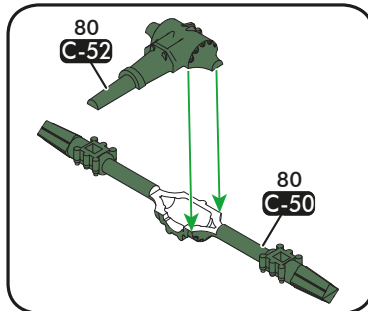
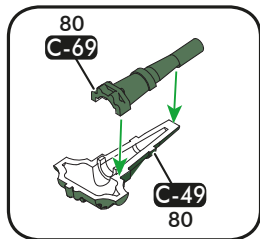

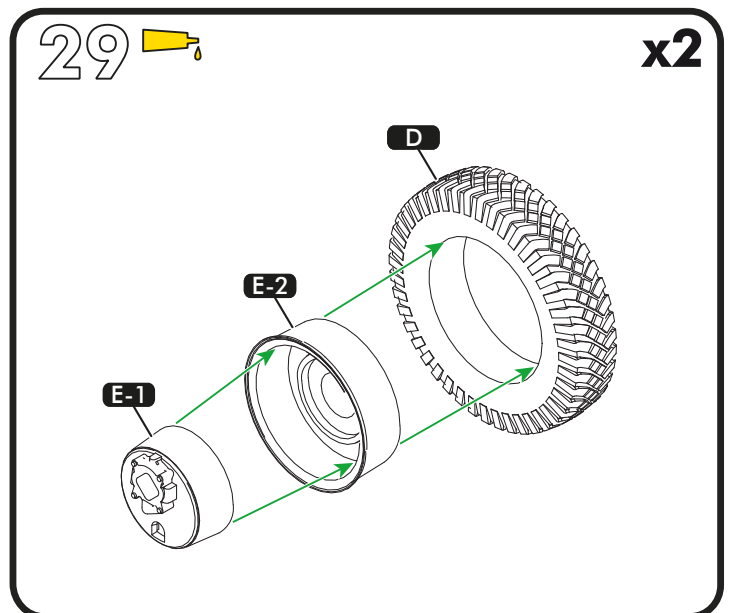
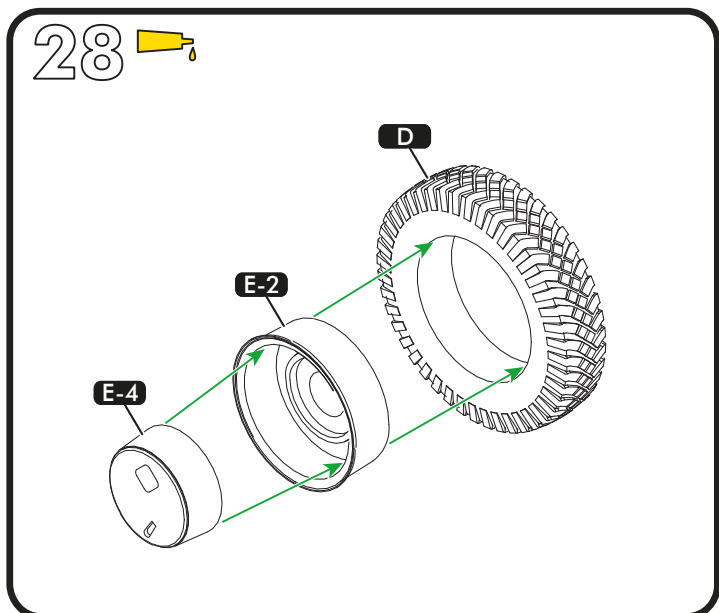
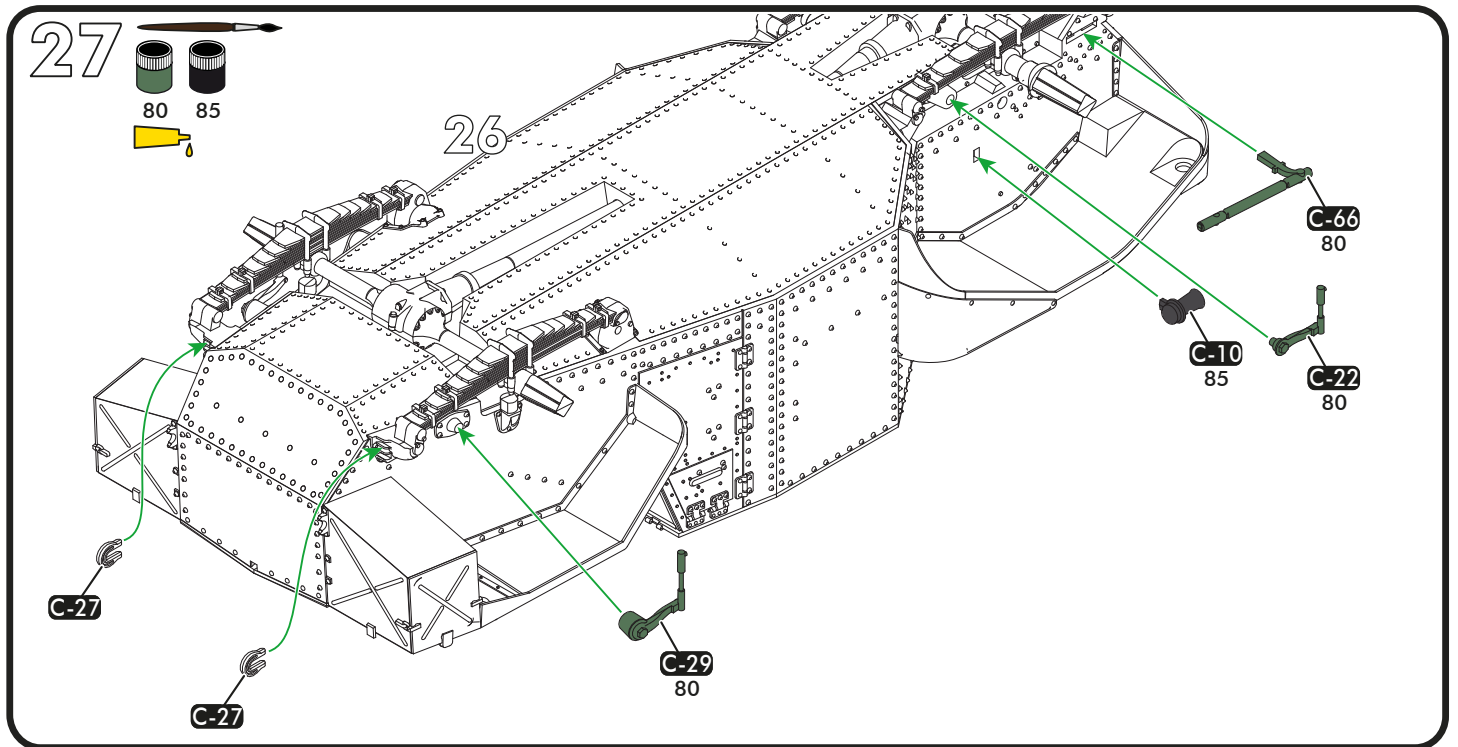
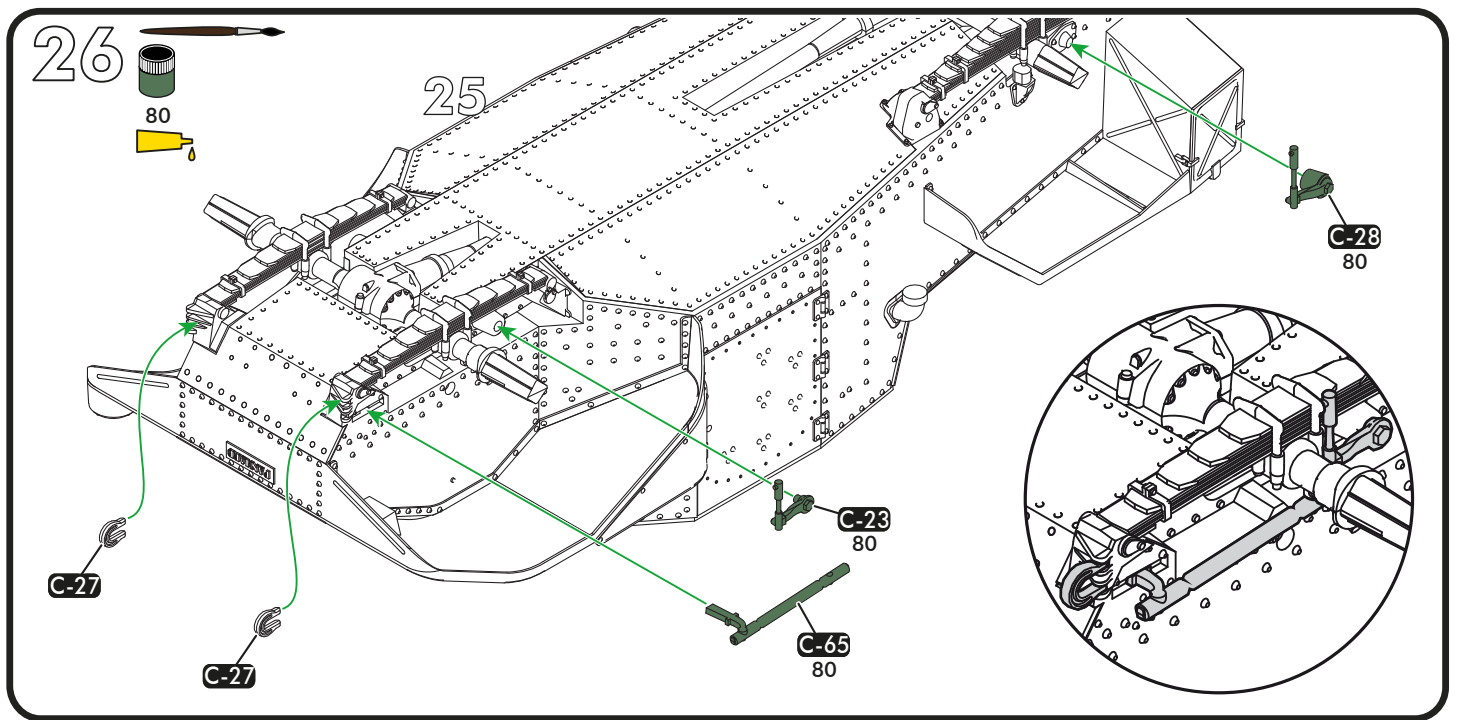

30

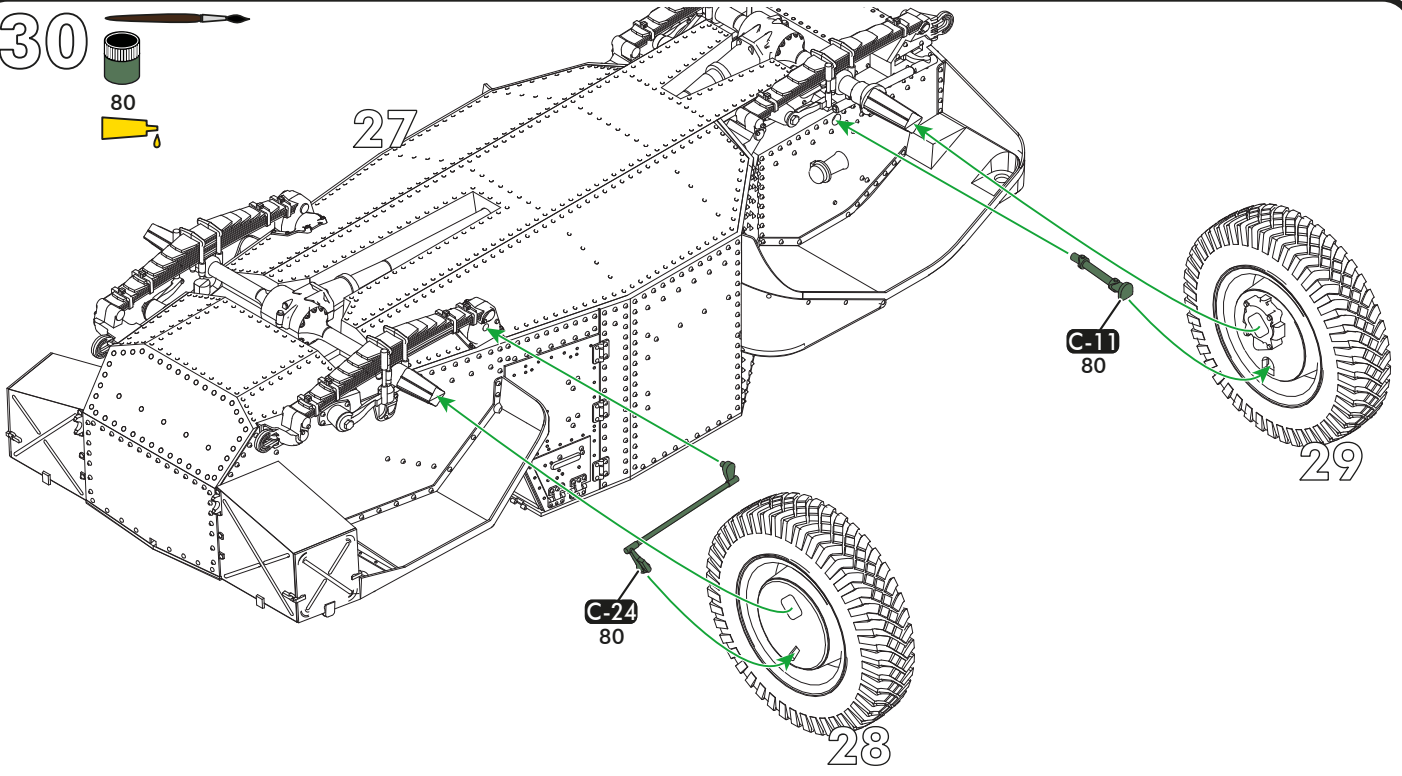
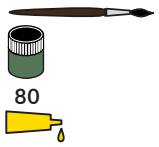

31

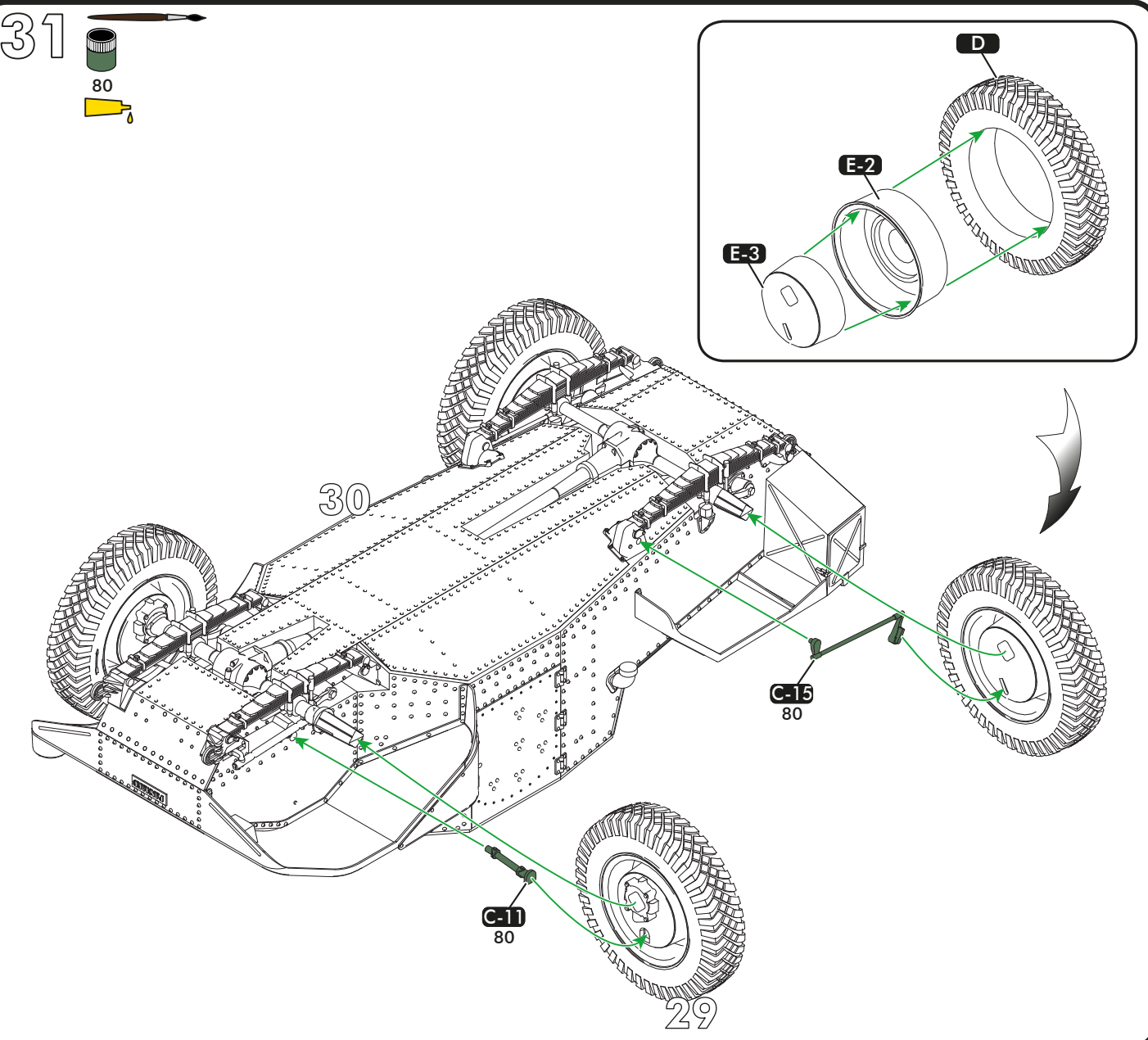
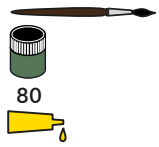

32

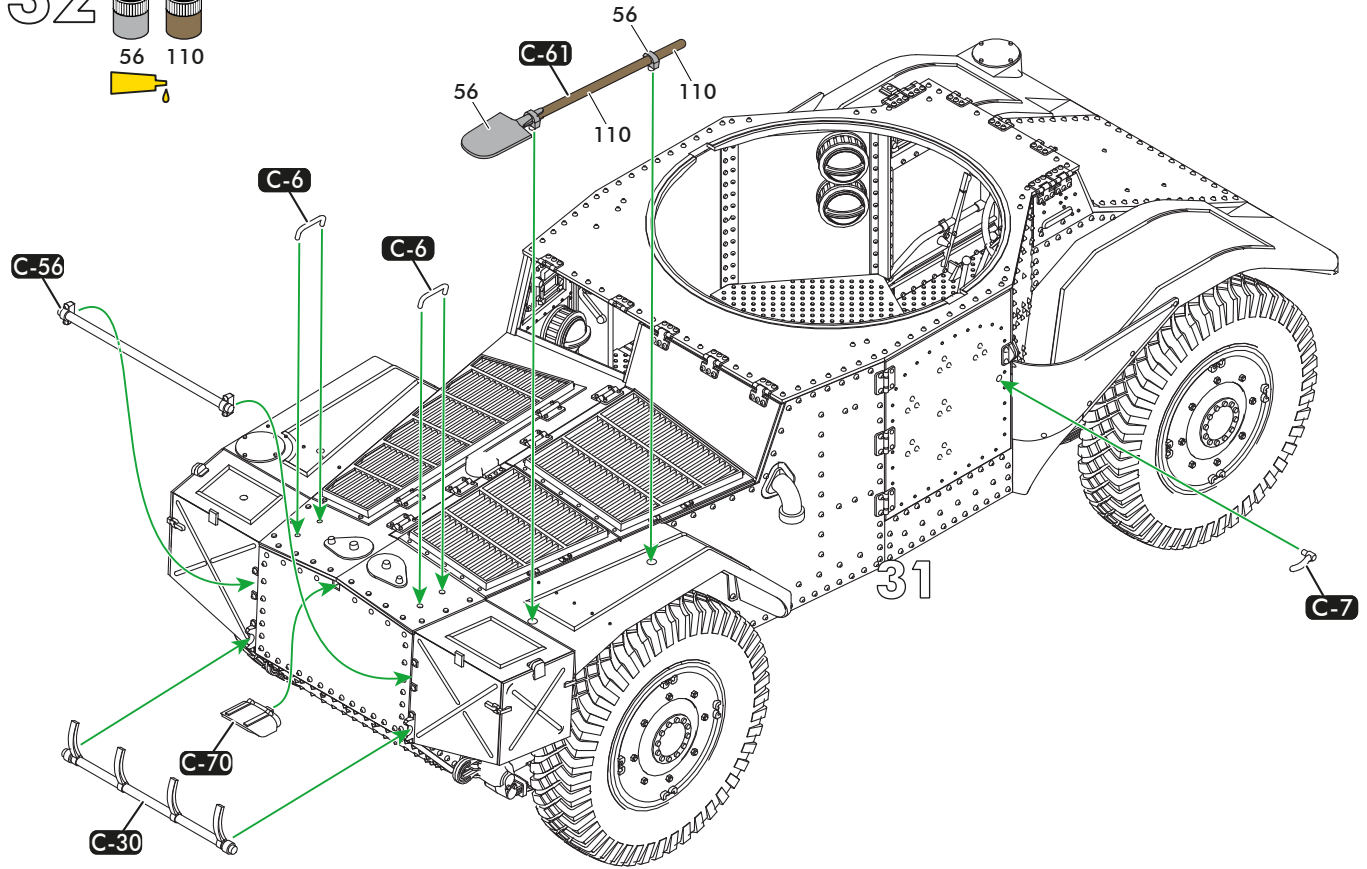
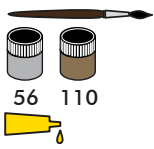

33

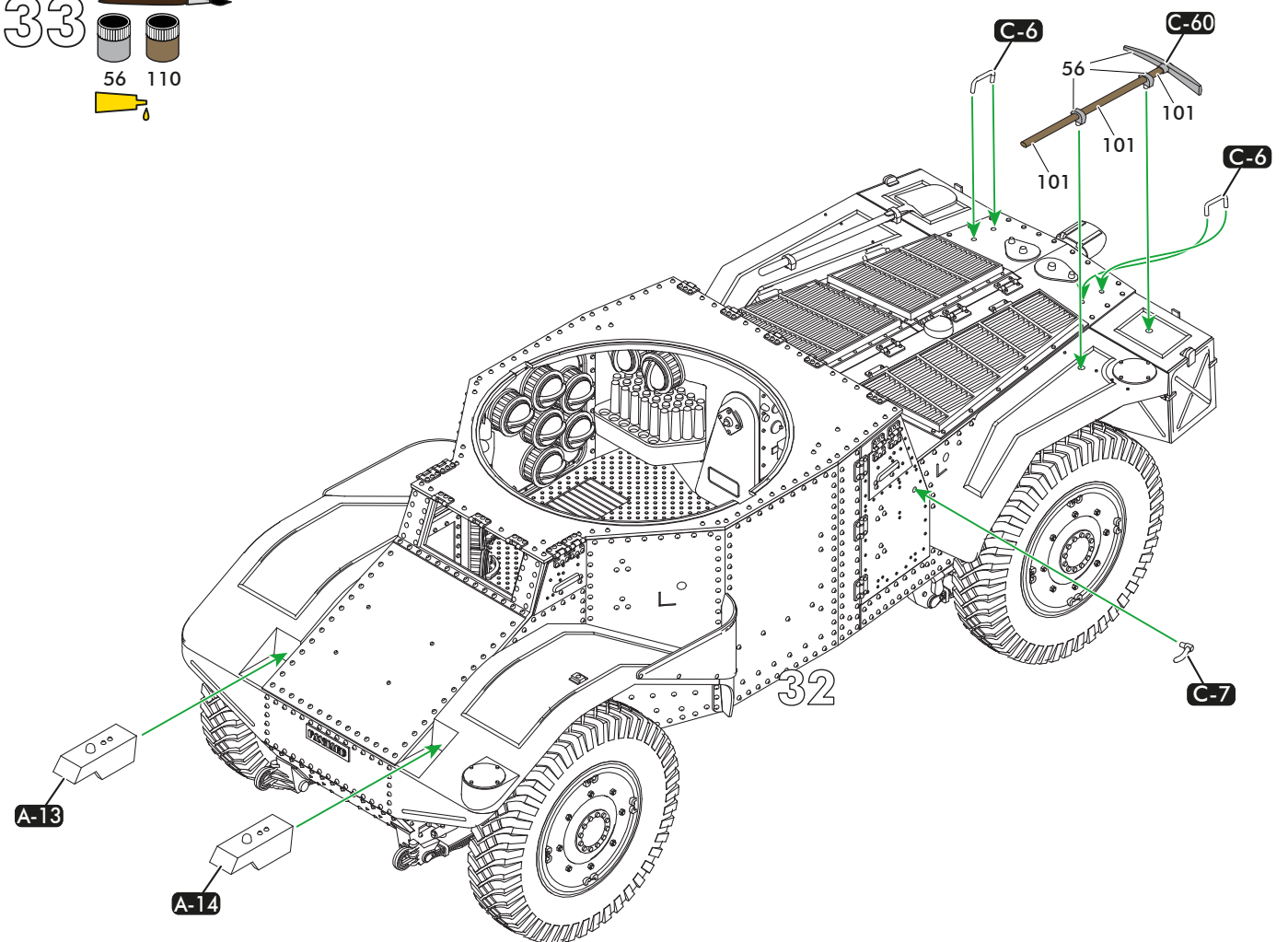
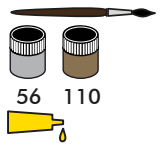

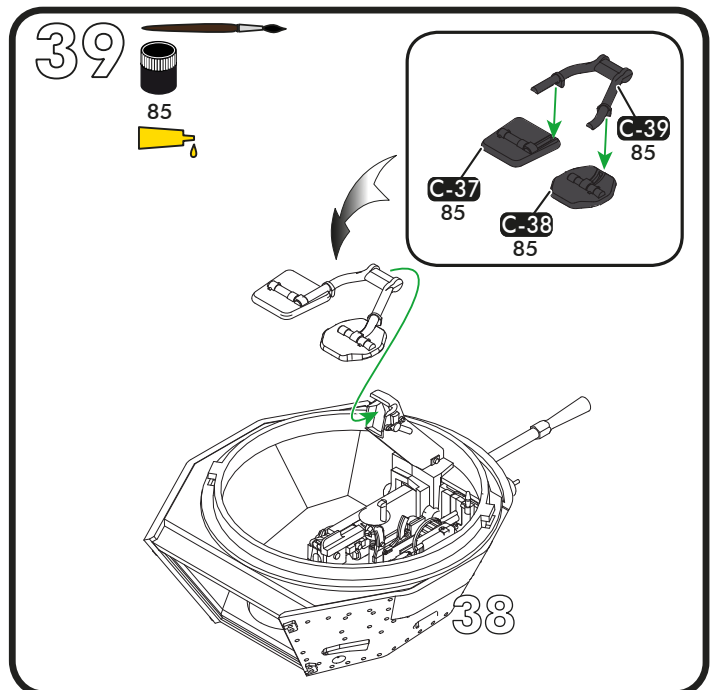
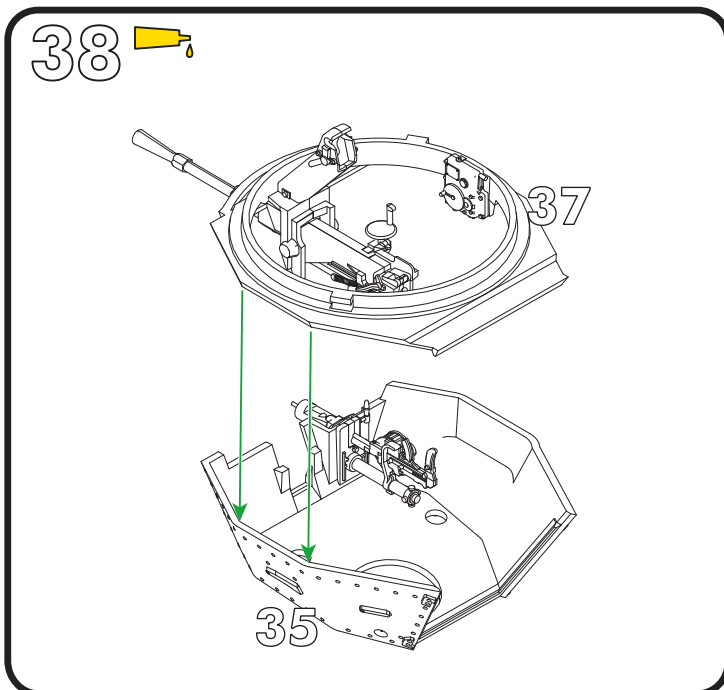
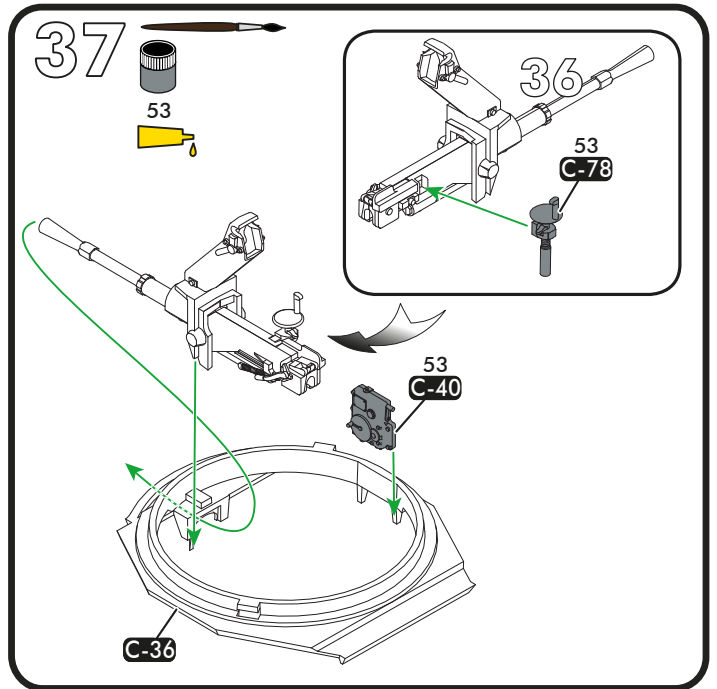
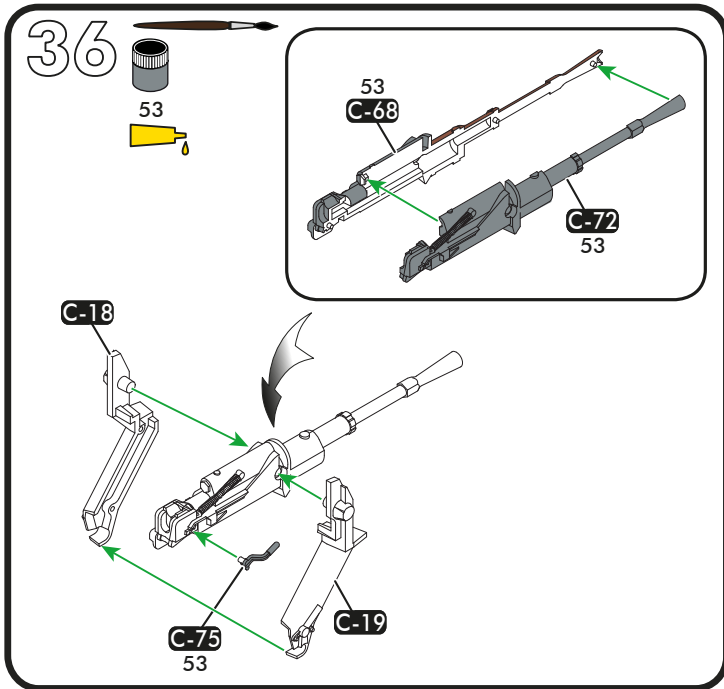
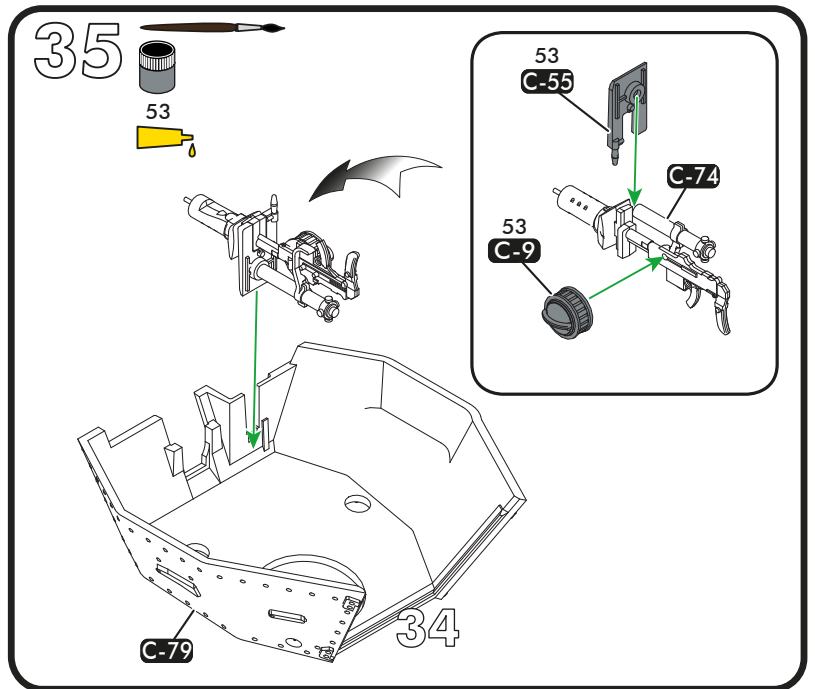
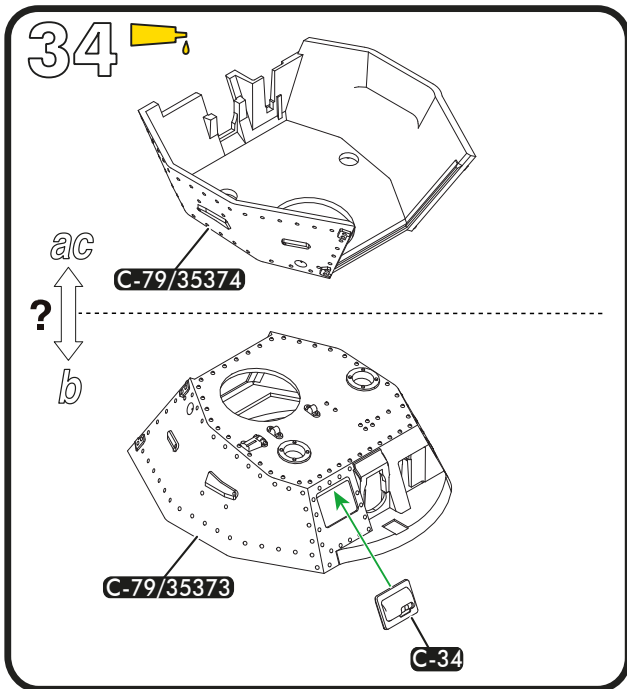

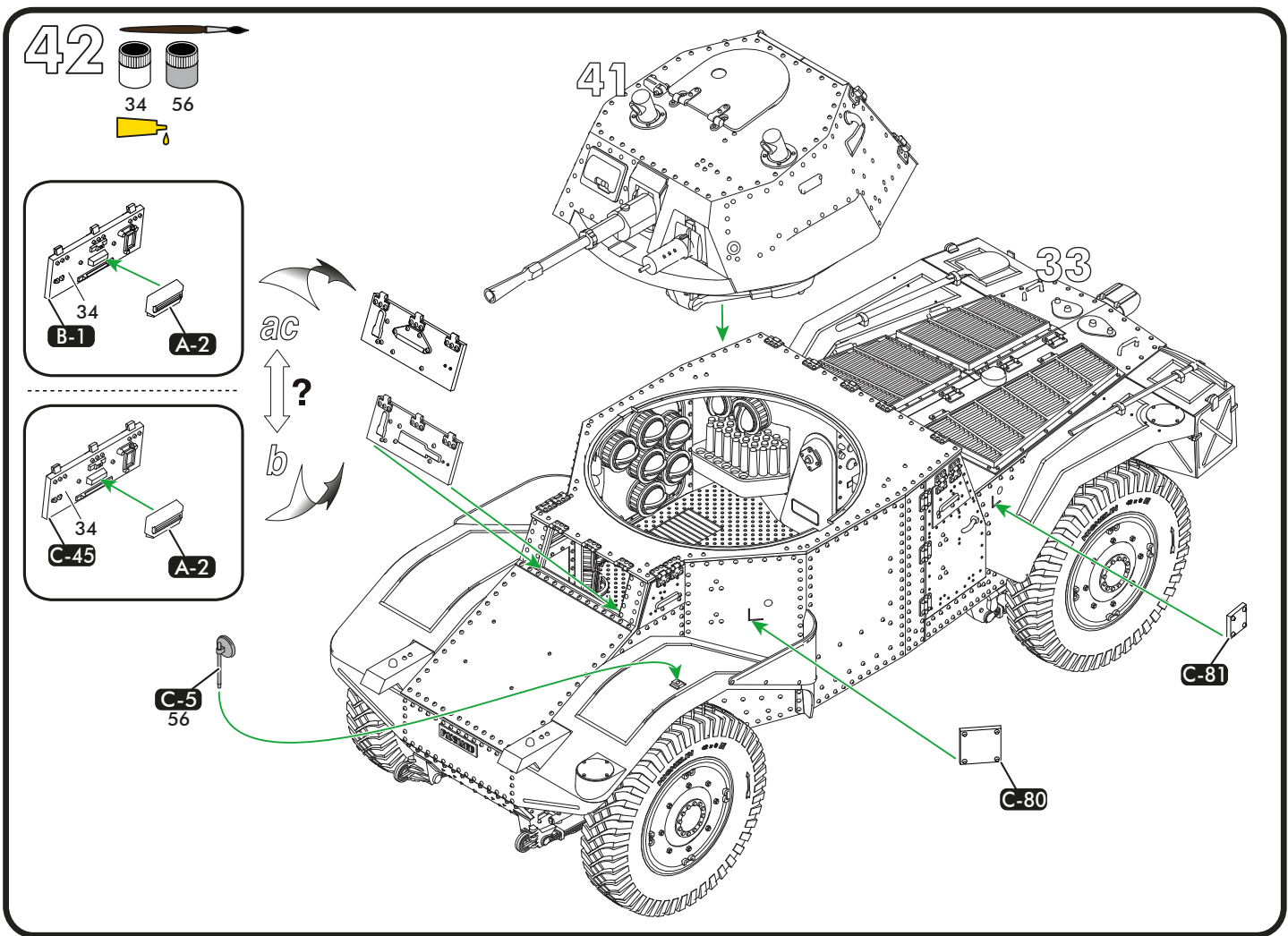
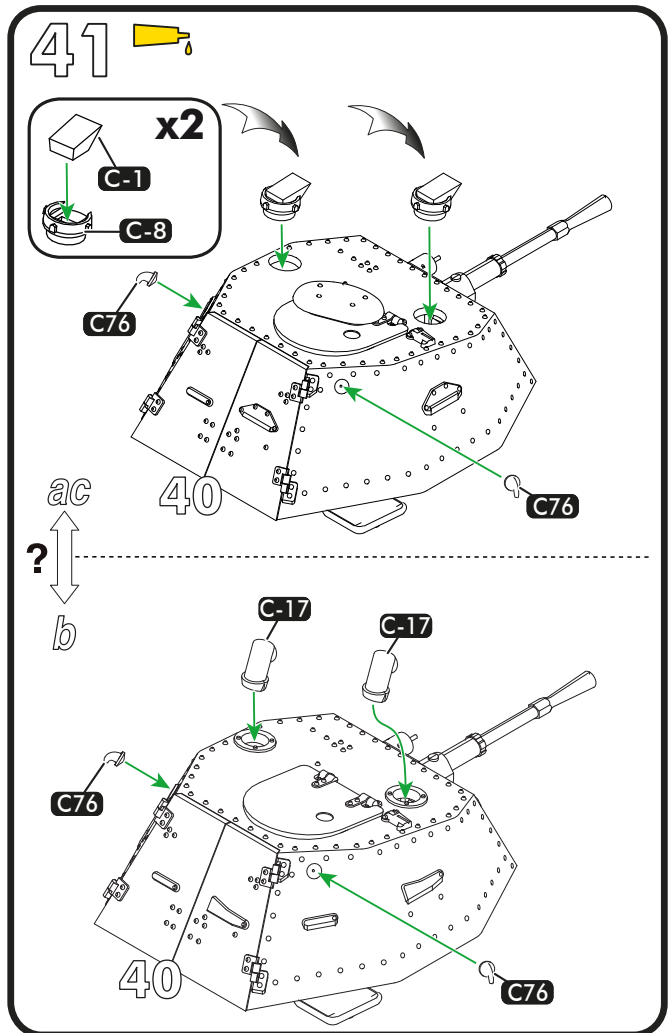
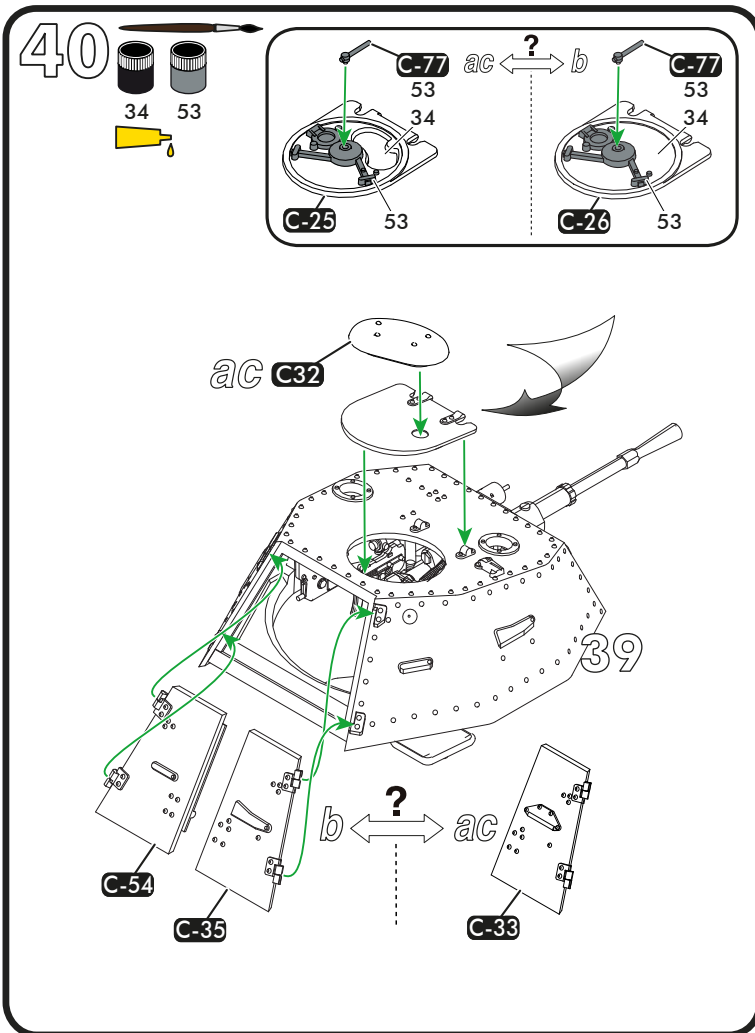

43

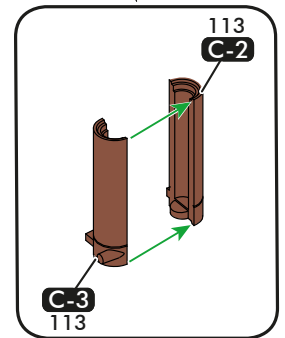
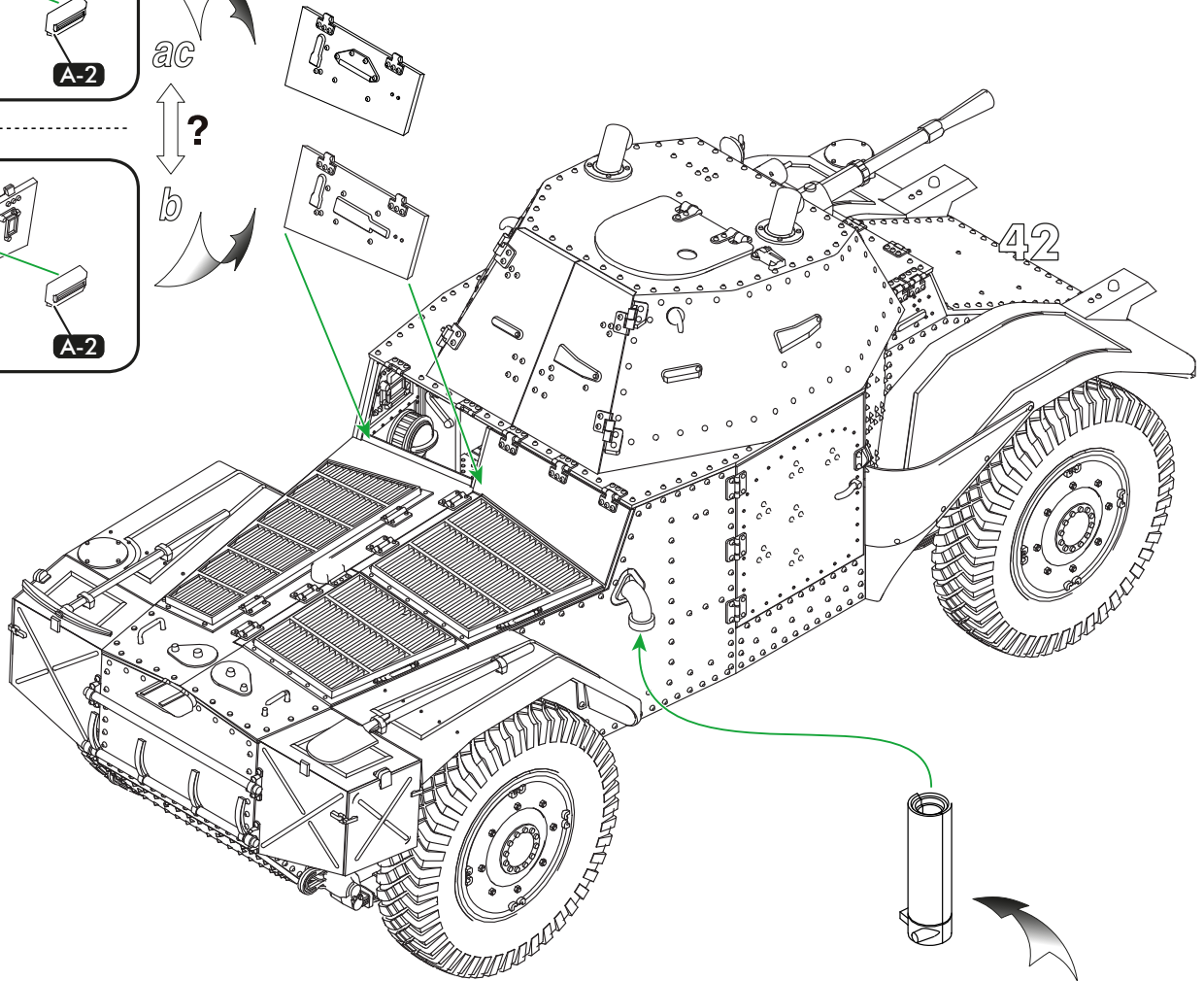
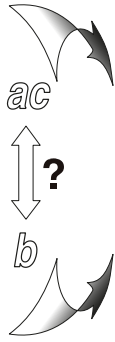
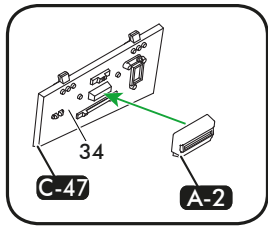
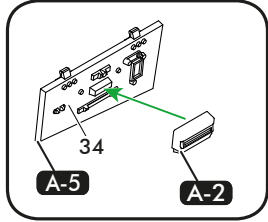
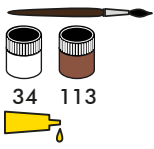



44

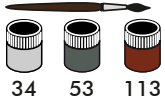

- a* - Véhicule blindé de reconnaissance Panhard 178 P 204(f) WH-622629 : 2<sup>e</sup> Bataillon de Reconnaissance, 2<sup>e</sup> Division blindée, front de l'Est, hiver 1941.  
 - Armored reconnaissance vehicle Panhard 178 P 204(f) WH-622629: 2<sup>nd</sup> Reconnaissance Battalion, 2<sup>nd</sup> Armored Division, Eastern Front, Winter 1941.

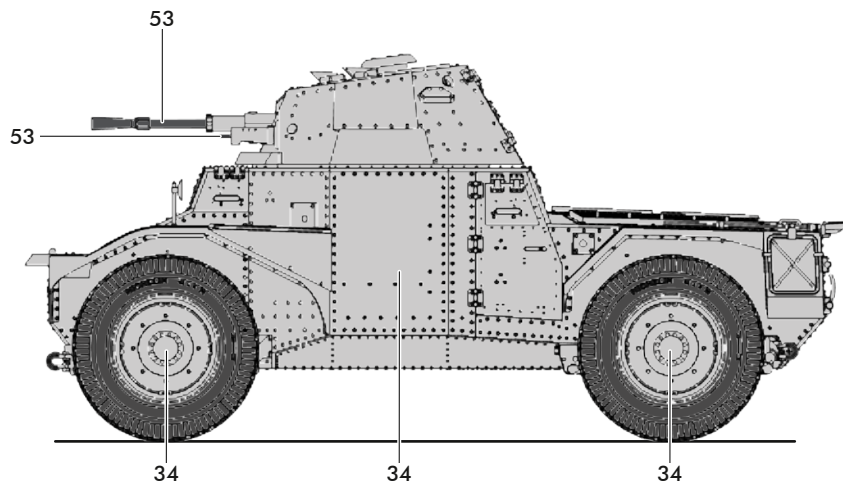
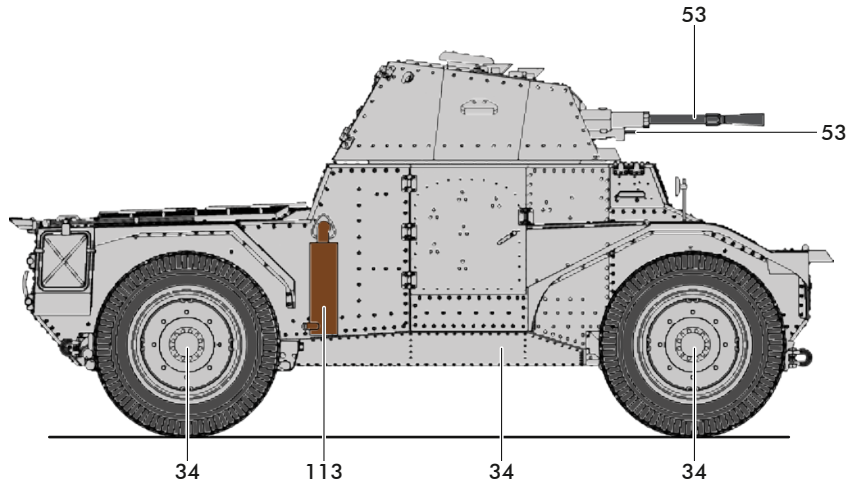
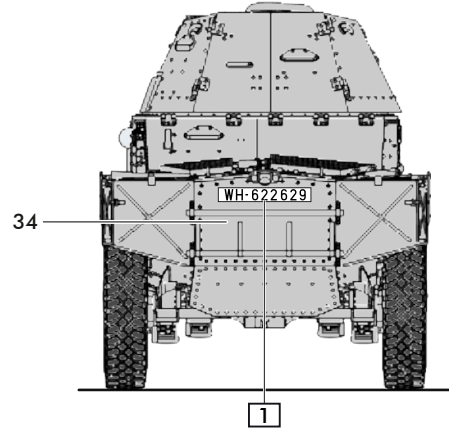
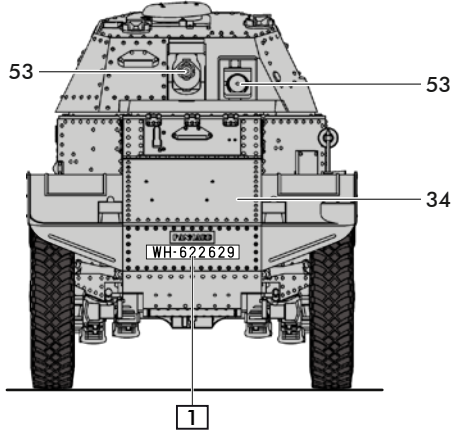

44



*b.* - Panhard 178 AMD 35 N° 91659: 1<sup>re</sup> DLM (Division Légère Mécanique), 6<sup>e</sup> Régiment de Cuirassiers, 1<sup>er</sup> Escadron, 1<sup>er</sup> peloton, Zuidweg (Hollande), mai 1940.  
 - Panhard 178 AMD 35 No. 91659: 1<sup>st</sup> DLM (Division Légère Mécanique), 6<sup>th</sup> Cuirassiers Regiment, 1<sup>st</sup> Squadron, 1<sup>st</sup> Platoon, Zuidweg (Holland), May 1940.

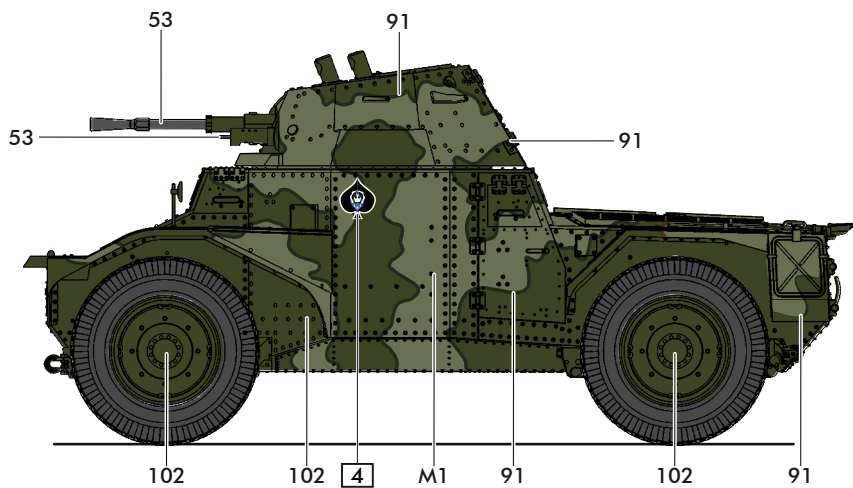
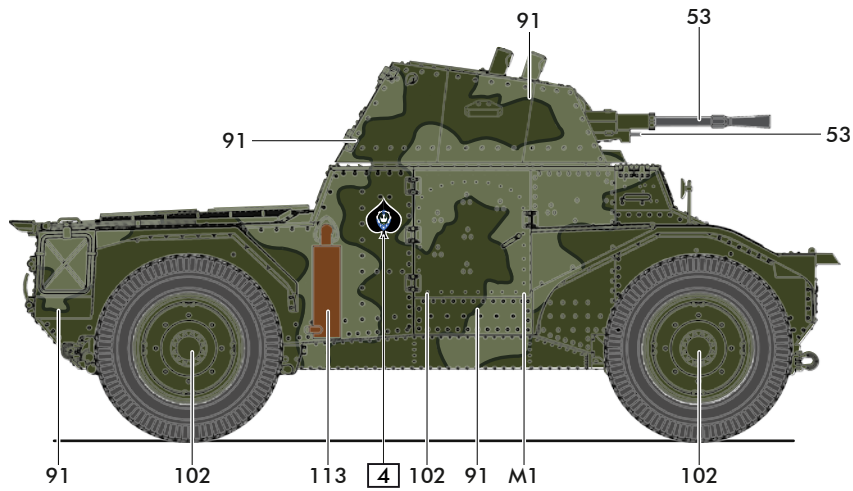
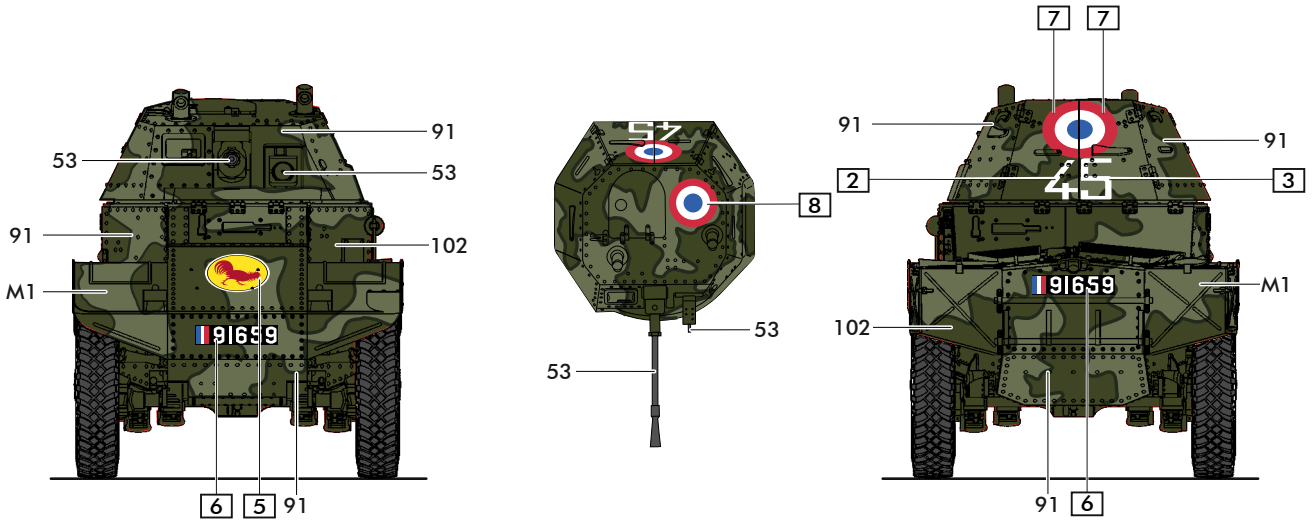

44



C - Panhard 178 AMD 35 N° M-7635: 3<sup>e</sup> DLC (Division Légère de Cavalerie),  
 3<sup>e</sup> RAM (Régiment d'Auto-Mitrailleuses), 1<sup>er</sup> Escadron, Luxembourg, mai 1940.  
 - Panhard 178 AMD 35 N° M-7635: 3<sup>e</sup> DLC (Division Légère de Cavalerie),  
 3<sup>e</sup> RAM (Régiment d'Auto-Mitrailleuses), 1<sup>er</sup> Squadron, Luxembourg, May 1940.

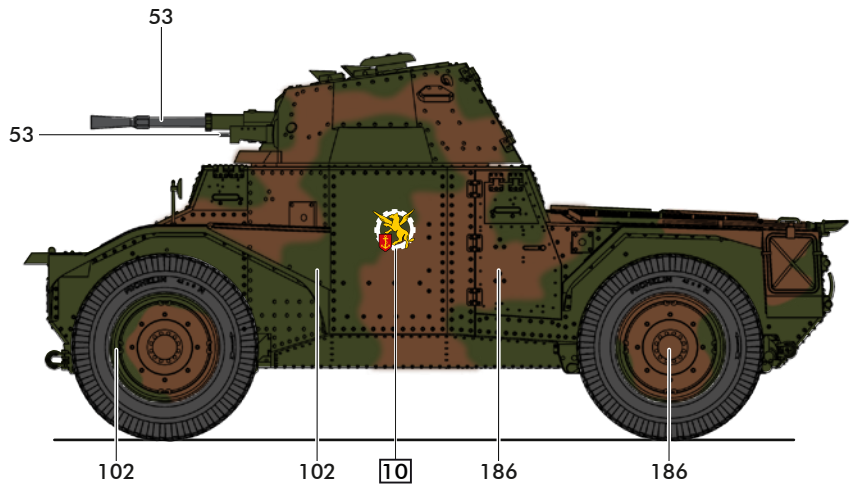
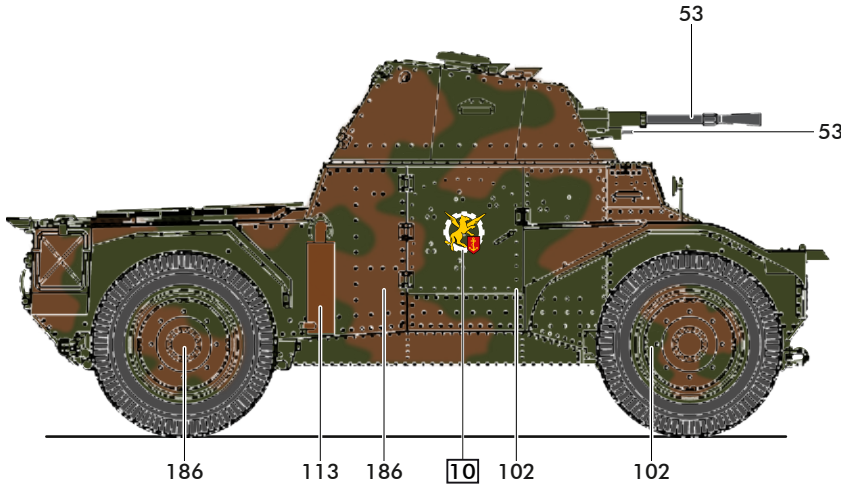
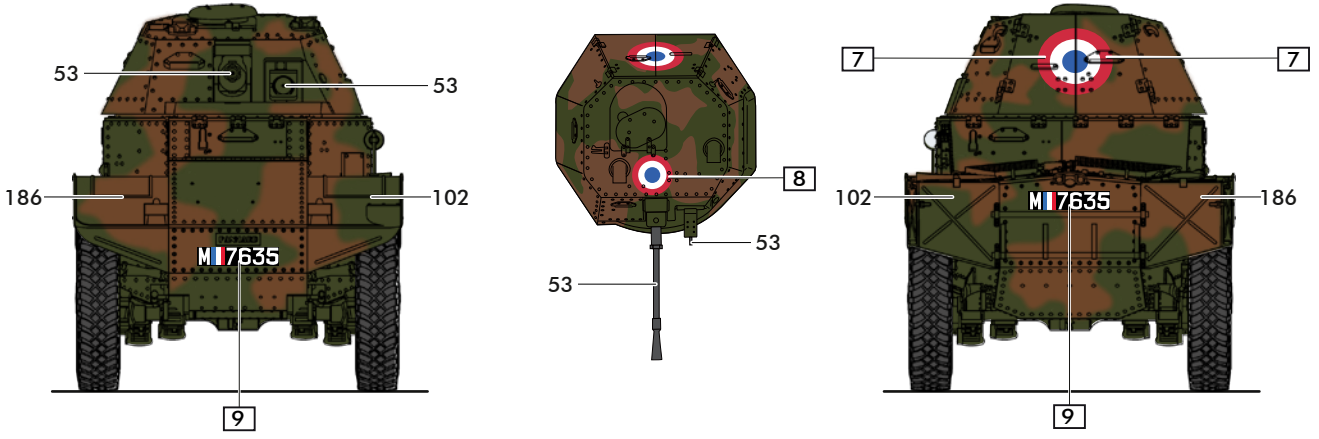

# VISITEZ-NOUS EN LIGNE !

VISIT US DIGITALLY!  
BESUCHEN SIE UNS DIGITAL!

 [www.heller.fr](http://www.heller.fr)

 [instagram.com/heller.fr](https://www.instagram.com/heller.fr)

 [facebook.com/heller.fr](https://www.facebook.com/heller.fr)

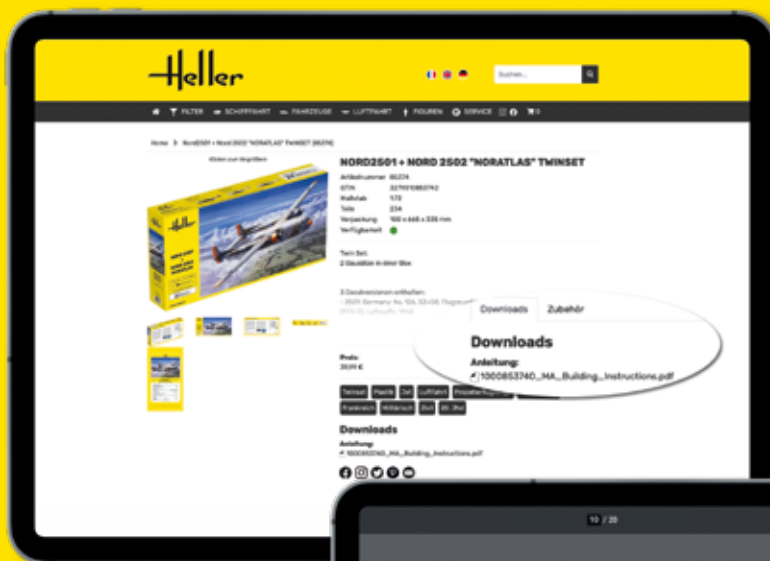

Choisissez l'article désiré et téléchargez la notice de montage.  
Choose your desired article and download the instructions.  
Wählen Sie den gewünschten Artikel und laden Sie die Anleitung herunter.

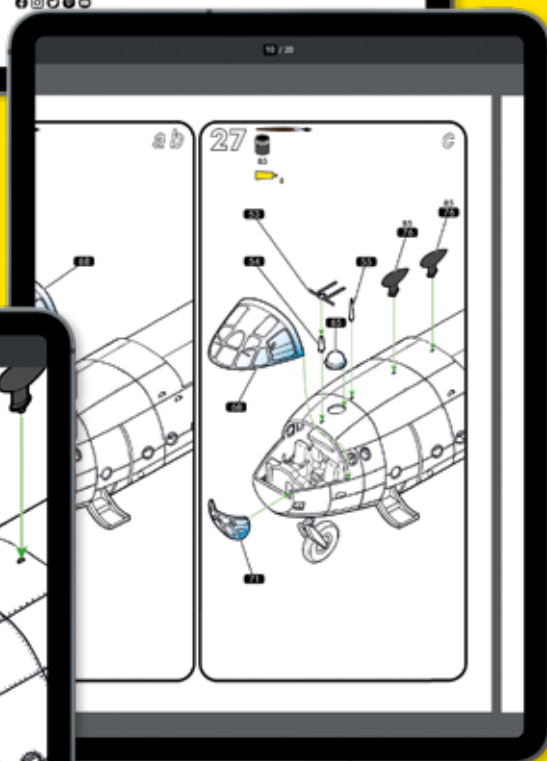

**Download all  
instructions!**

Grossissement des instructions pour  
une vue détaillée.



Enlarge the instructions for a more  
detailed view.

Vergrößern Sie die Anleitung für eine  
detailliertere Ansicht.

**Service consommateurs**  
Pour toute demande de SAV, connectez-vous  
sur notre site [www.heller.fr](http://www.heller.fr).

**Customer Service**  
For after-sales service requests,  
please contact us through our website  
[www.heller.fr](http://www.heller.fr).

**Endverbraucherservice**  
Bitte besuchen Sie uns auf [www.heller.fr](http://www.heller.fr)  
für alle Ersatzteilanfragen.

**Heller Hobby GmbH**  
Erlenbacher Str. 3 • 42477 Radevormwald • GERMANY  
 +49 (0) 2195-92773-0  [info@heller.fr](mailto:info@heller.fr)