

TITANIC SEARCHER "Le Suroit"



80615

F Construit par les Ateliers et Chantiers de la Manche à Dieppe, et mis en service en avril 1975, ce navire est la seconde unité, après "Le Noroit", de la série des "N.O.R.O.I.S." (Navires Océanographiques de Recherche, d'Observation et de Soutien) conçue pour le CNEXO (Centre National pour l'Exploitation des Océans).
Le 5 juin 1984, l'IFREMER (Institut Français de Recherche pour l'Exploitation de la MER) est créé et reprend à sa charge les fonctions du CNEXO.
Le Suroit participa activement à la recherche de l'épave du Titanic au cours de l'été 1985, grâce au S.A.R. (Sonar Acoustique Remorqué) un instrument de détection très perfectionné.

Longueur hors tout: 56,34 m
Largeur hors membre: 11 m
Tirant d'eau moyen: 4,50 m
Déplacement en charge: 1094 tonnes
Vitesse maximum: 14 noeuds
Effectif embarqué: équipage 35 dont 7 officiers, 13 scientifiques
Propulsion principale: 2 moteurs diesel 1650 cv

D Die Jungfernfahrt von «Le Suroit» fand im April 1975 statt. Sie war von den Ateliers et Chantiers de la Manche in Dieppe konstruiert worden. Es handelte sich um das zweite Forschungsschiff (nach «Le Noroit») aus der Serie «N.O.R.O.I.S.» (meereskundliche Forschungsschiffe, Beobachtungsstützpunkte), die für das «Nationale Zentrum zur Erforschung des Ozeans» entworfen wurden.
Am 5. Juni 1985 wurde das IFREMER (Französisches Forschungsinstitut für die Meeresnutzung) gegründet und übernahm «Le Suroit». Im Laufe des Sommers 1985 nahm sie aktiv an der Erforschung des Wracks der Titanic teil und leistete hierbei dank des S.A.R. (Sonar Acoustique Remorqué), einem sehr empfindlichen Aufspürungsinstrument, sehr gute Arbeit.

Länge 56,34 m
Breite 11,00 m
Mittlerer Tiefgang 4,50 m
Zuladungsgewicht 1094 Tonnen
Max. Geschwindigkeit 14 Knoten
Mannschaftsstärke 35 Personen - davon: 7 Offiziere
13 Wissenschaftler
Hauptantrieb 2 Dieselmotoren 1650 PS

NL Door de "Ateliers et Chantiers de la Manche" te Dieppe gebouwd en in april 1975 in bedrijf gesteld, is dit vaartuijg de tweede eenheid na "Le Suroit", van de serie der "N.O.R.O.I.S." (Oceanografische opzoekingsvaartuigen en steunvaartuigen) voor CNEXO ontworpen.
Op 5 juni 1984 werd het Franse Instituut voor Onderzoek t.b.v. Zee-exploitatie (IFREMER) opgericht, dat de functies van het CNEXO (Nationaal Centrum voor Oceaononderzoek) overnam.
De Suroit deed actief mee aan de zoektochten naar het wrak van de Titanic gedurende de zomer van 1985 en maakte daarbij gebruik van de S.A.R. (Gesleepte Akoestische sonar), een bijzonder hoogwaardig detectie-instrument.

I Costruita a Dieppe, dalle Officine e Cantieri Navali della Manica, e messa in servizio nell'aprile 1975, questa nave è, dopo il "NOROIT", la seconda unità della serie dei "N.O.R.O.I.S." (Navi Oceanografiche di Ricerca, Osservazione e Appoggio), progettata dallo CNEXO (Centro Nazionale per lo Sfruttamento degli Oceani).
Il 5 giugno 1984, viene fondato l'IFREMER (Istituto Francese di Ricerca per lo Sfruttamento del Mare) che prende a carico le funzioni del CNEXO.
Il Suroit partecipa attivamente alla ricerca del relitto del Titanic durante l'estate del 1985 grazie al S.A.R. (Sonar Acustico Rimorchiato), che è uno strumento di individuazione particolarmente perfezionato.

GB Built by the Channel shipyards at Dieppe and brought into service in April 1975 this ship was the second after «le Noroit» of the Oceanographic Research and Support series of vessels.
The Suroit made a positive contribution in the search for the wreck of the Titanic during the summer of 1985 thanks to the its trailing sonar detector, a highly precise detection instrument.

Length 56.34 m
Width 11 m
Draught 4.50 m
Displacement 1.094 tons
Maximum speed 14 knots
Engine 2 motors 1.650 cv

E Construido por los "Ateliers et Chantiers de la Manche de Dieppe" (Astilleros de la Manche de Dieppe) y puesto en servicio en abril 1975 este navío es la segunda unidad, después de "Le Noroit", de la serie de los "N.O.R.O.I.S." (Navios Oceanograficos de Investigación Observación y Apoyo) concebida para el CNEXO (Centro Nacional para la Explotación de los Océanos).
El 5 de junio de 1984, se creó el IFREMER (Institut Français de Recherche pour l'Exploitation de la MER) (Instituto Francés de Investigación para la Explotación del Mar), que se hizo cargo de las funciones del CNEXO.
El Suroit participó activamente en la búsqueda de los restos del Titanic durante el verano de 1985, gracias al S.A.R. (Sonar Acústico Remolcado), un instrumento de detección sumamente perfeccionado.

Longitud de extremo a extremo 56,34 m
Anchura de trazado 11 m
Calazón medio 4,50 m
Desplazamiento en carga 1.094 toneladas
Velocidad máxima 14 nudos
Efectivo embarcado Tripulación 35 de la que 7 oficiales, 13 científicos

GR Το πλοίο αυτό κατασκευάστηκε από την εταιρεία "Ateliers et Chantiers de la Manche" στην πόλη Dieppe, και τέθηκε σε χρήση τον Απρίλιο του 1975. Είναι το δεύτερο από μια σειρά ερευνητικών σκαφών, το πρώτο των οποίων ήταν το "Noroit". Πρόκειται για ειδικά σκάφη για την εξερεύνηση και την παρατήρηση του ωκεανού, που σχεδιάστηκαν από το γαλλικό Εθνικό Κέντρο για την Εκμετάλλευση των Ωκεανών (CNEXO).
Στις 5 Ιουνίου 1984 δημιουργήθηκε το IFREMER (Γαλλικό Ινστιτούτο για την Εξερεύνηση και την Εκμετάλλευση της Θαλάσσης) που ανέλαβε τα καθήκοντα του CNEXO.
Το Suroit συμμετείχε δυναμικά στην αναζήτηση του ναυαγίου του Τιτανικού στο τέλος του καλοκαιριού του 1985, με τη βοήθεια του S.A.R. (Ρυμουλκούμενο Ακουστικό Σόναρ), ένα πολύ προηγμένο όργανο ανίχνευσης.

P Construido pelas Oficinas e Estaleiros da Mancha em Dieppe, e posto em serviço em Abril de 1975, este navio é a segunda unidade, depois do "Le Noroit", da série dos "N.O.R.O.I.S." (Navios Oceanográficos de Investigação, de Observação e de Apoio) concebidos pelo CNEXO (Centro Nacional de Exploração dos Oceanos).
Em 5 de Junho de 1984, o IFREMER (Instituto Francês de Investigação para a Exploração do MAR) foi criado e tomou a seu cargo as funções do CNEXO.
Le Suroit participou activamente nas investigações sobre os destroços do Titanic durante o Verão de 1985, graças ao S.A.R. (Sonar Acústico Rebocado), um instrumento de detecção muito aperfeiçoado.



2

Vert Emeraude brillant
Gloss emerald
Glänzend-Smaragdgrün



11

Argent
Silver
Silber



12

Cuivre jaune
Copper
Kupfer



19

Rouge vif brillant
Gloss bright red
Glänzend-Hellrot



69

Jaune brillant
Gloss yellow
Glänzend-Gelb



73

Lie de vin mat
Matt wine
Matt-Wein



80

Vert pré mat
Matt grass green
Matt-Grasgrün



85

Noir de charbon satiné
Satin coal black
Seidenmatt-Kohlenschwarz



87

Gris acier mat
Matt steel grey
Matt-Stahlgrau



130

Blanc satiné
Satin white
Satinweiss

Phase de montage
 Assembly phase
 Fase de montaje
 Monteringsfase
 Montagephase
 Φάση συναρμολόγησης
 Fase di montaggio
 Montagefase
 Monteringsfase
 Fase de montagem
 Kokonamisvalta
 Monterings
 Montaż
 組立段階
 Этап сборки

Collor
 Cement
 Pegar
 Kleben
 Kleben
 Συγκόλληση
 Incollare
 Lijmen
 Limas
 Colar
 Limasa
 Limma
 Limma
 Skleić
 接着して下さい
 Приклеить

No pas collor
 Do not cement together
 No pegar
 Skal ikke klæbes
 Nicht kleben
 Μη κολλάτε
 Non incollare
 Niet lijmen
 Skal ikke limes
 Não colar
 Älä limaa
 Limma inte
 Nie sklejać
 接着しないで下さい
 Не клеить

Decalcomanias
 Decals
 Calcomanias
 Bildoverføring
 Bildoverføring
 Abziehbild
 Χαλκομανίες
 Decalcomanie
 Afdrukplaatjes
 Bildöverföring
 Decalcomanie
 Siirtokuvut
 Dekalkomanier
 Kalkomanie
 写し絵
 Переводные изображения

Couper
 Cut
 Cortar
 Skjære, klippe
 Schneiden
 Κοπή
 Tagliare
 Snijden
 Skjære, klippe
 Cortar
 Cortar
 Leikkaa
 Skära
 Przecinać
 切して下さい
 Отрезать

Riveter
 Join by applying heat
 Ribetisar
 Fastrette
 Fæstner
 Heiis verniäiti
 Πριτσίνωμα
 Ribadiri
 Klinken
 Klinker
 Ribitar
 Nitaa
 Niita
 Nitować
 釘打ちして下さい
 Соединить заклепкой

Pieça cristal
 Crystal part
 Pieza cristal
 Kristallstykke
 Kristallteil
 Διορθών κομμάτι
 Pezzo cristallo
 Kristallen onderdeel
 Kristallteil
 Peça de cristal
 Lasiosa
 Kristalldel
 Część przezroczysta
 クリスタル部品
 Хрустальная деталь

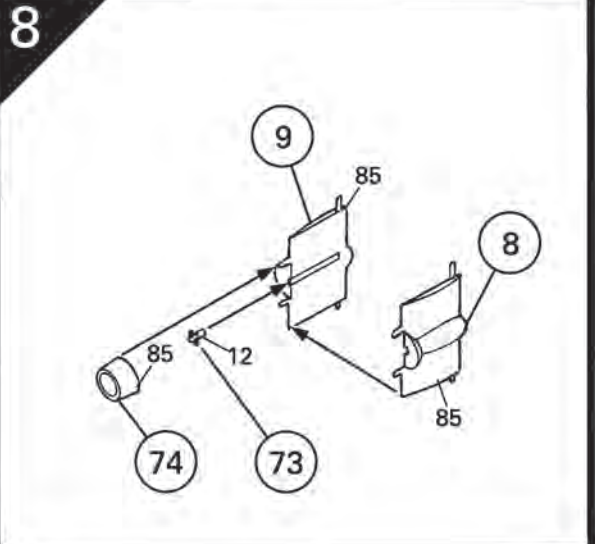
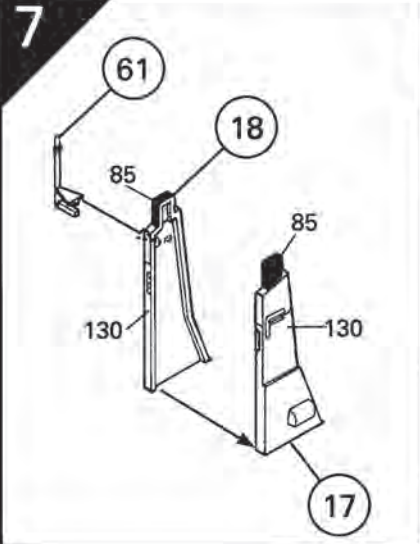
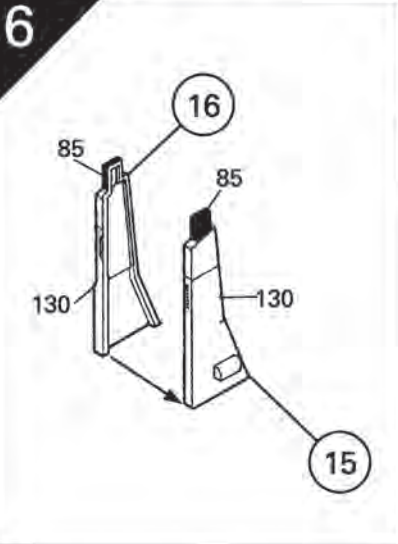
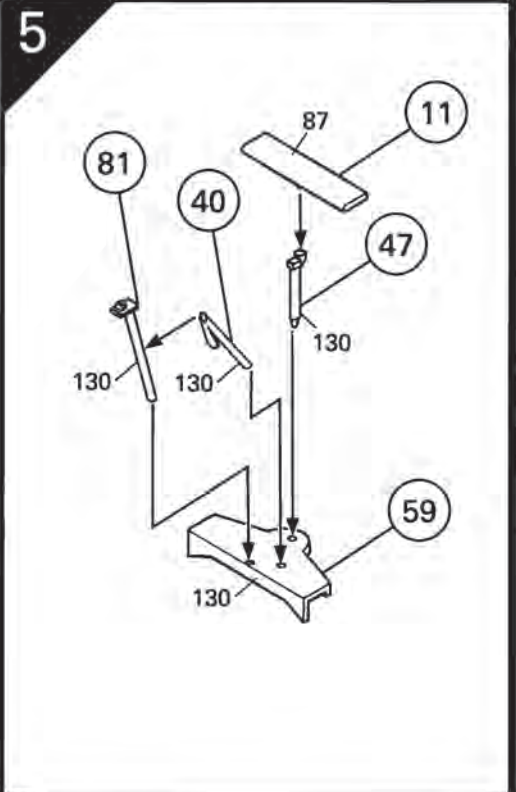
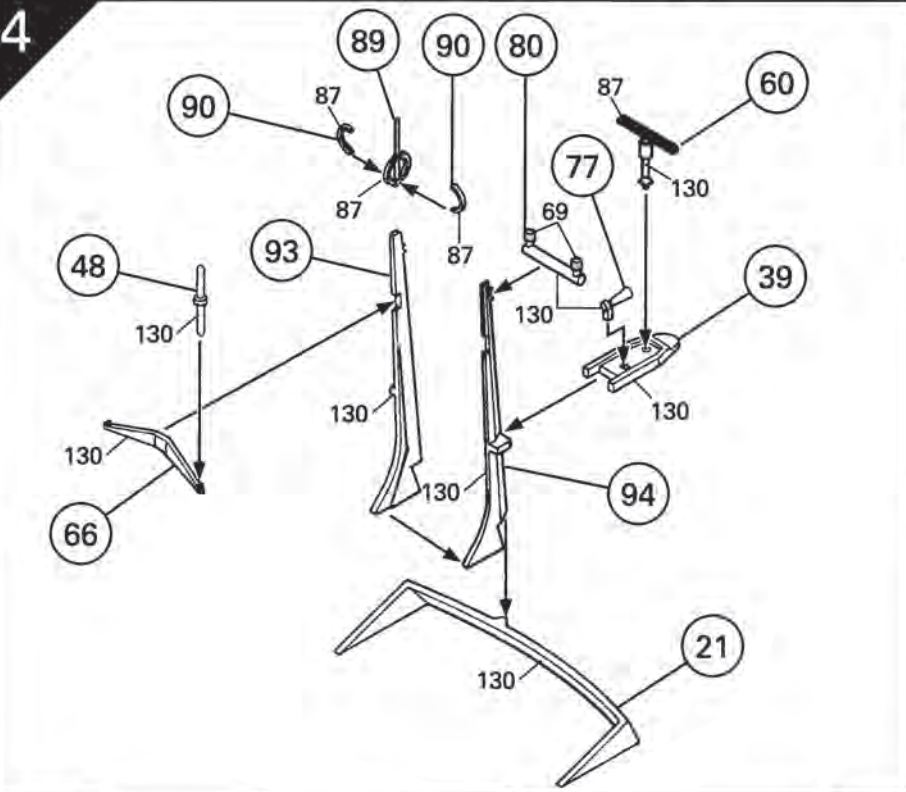
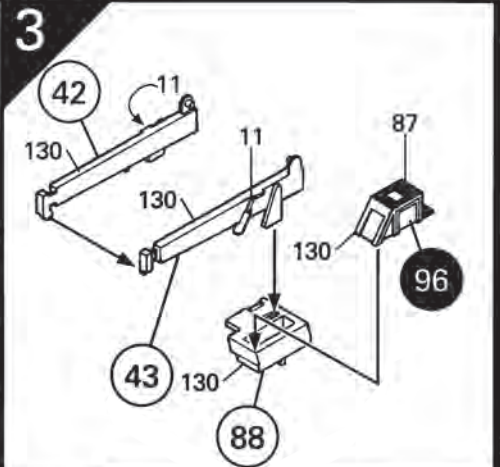
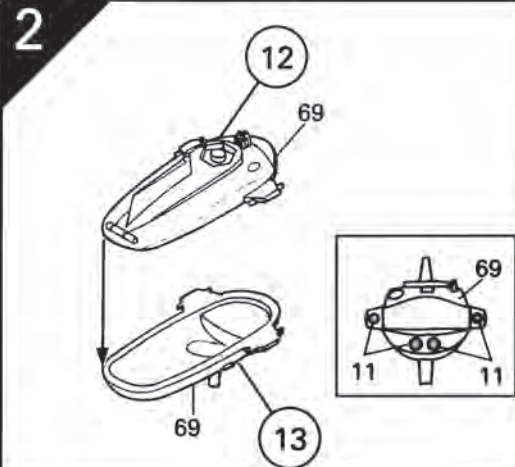
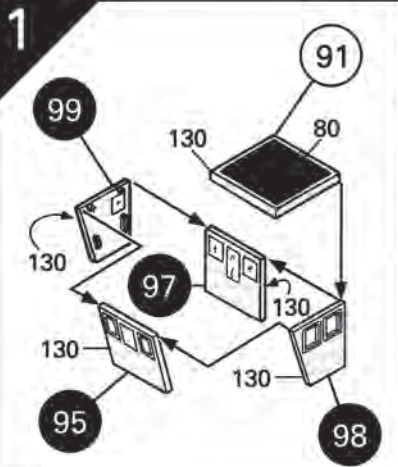

9

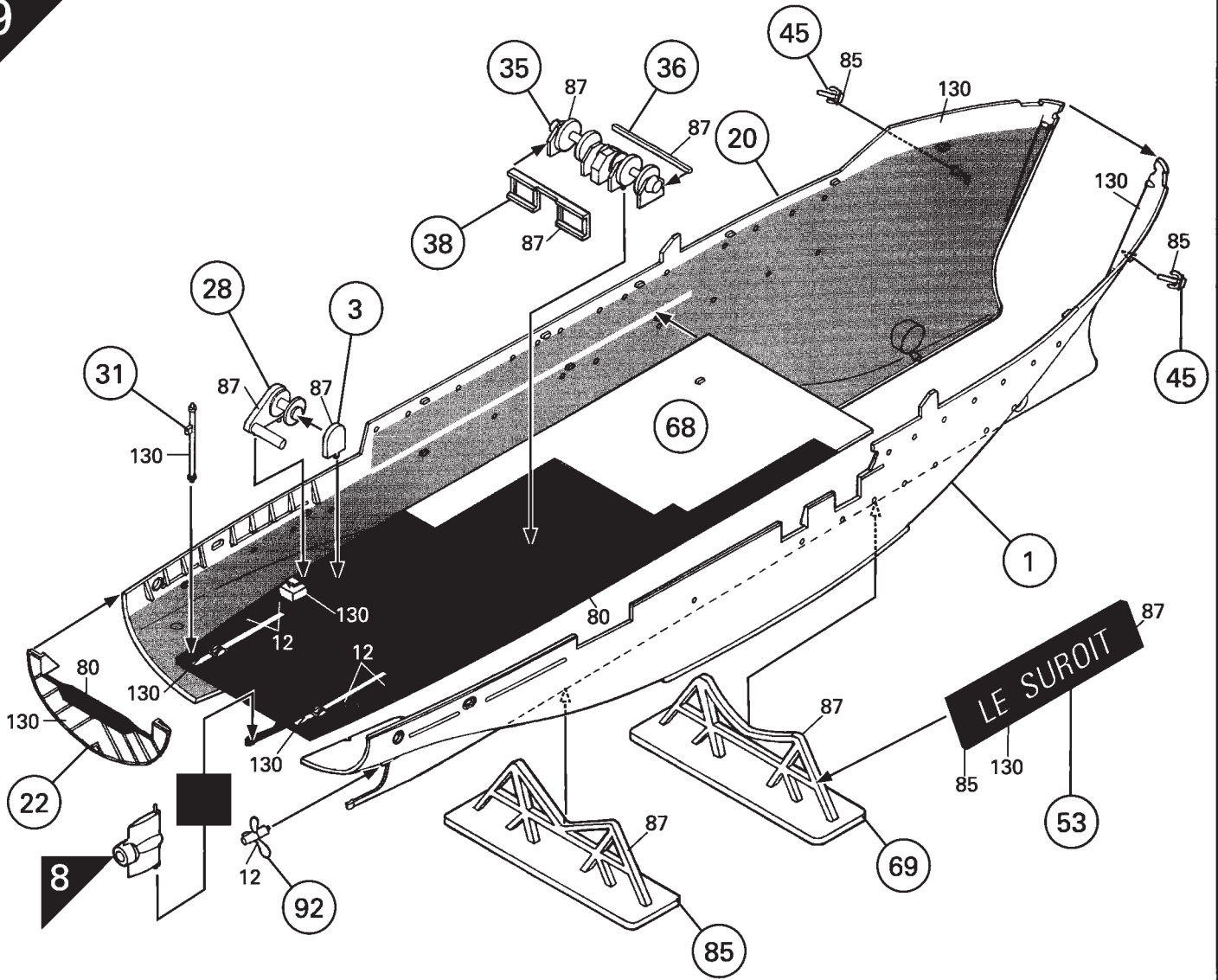

10

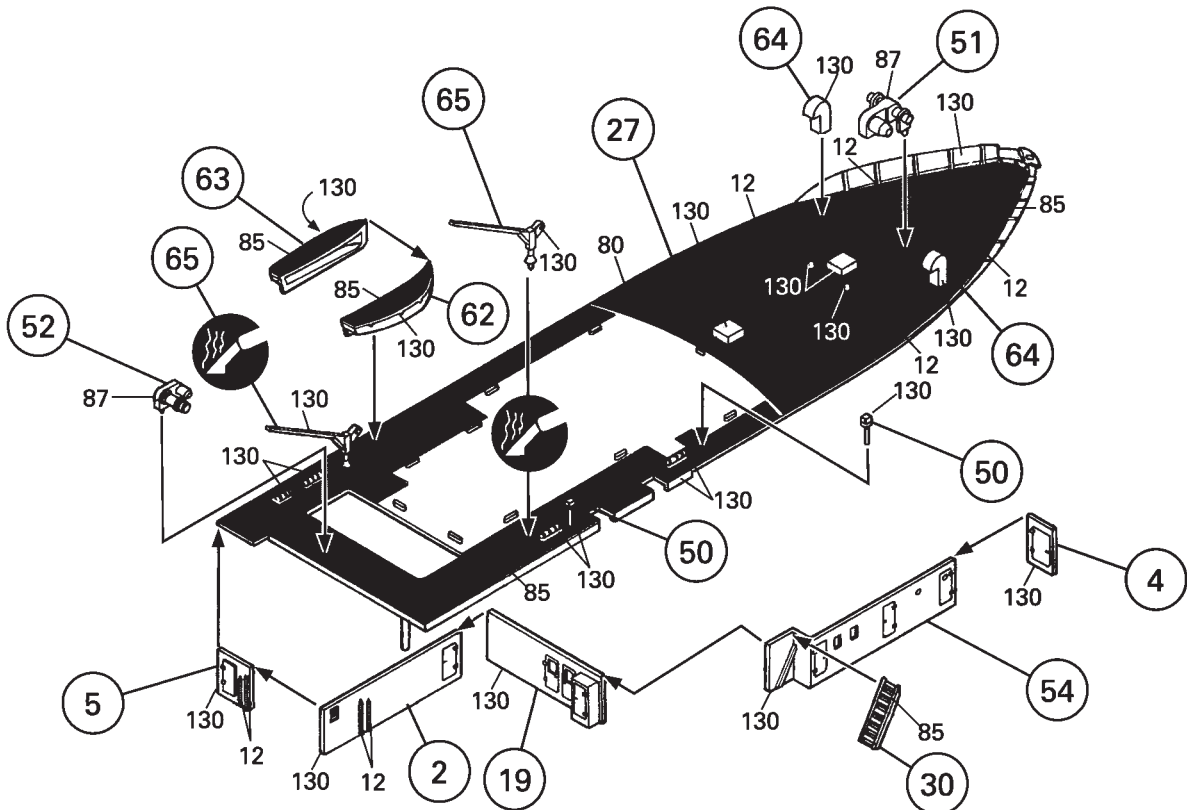

80615

11

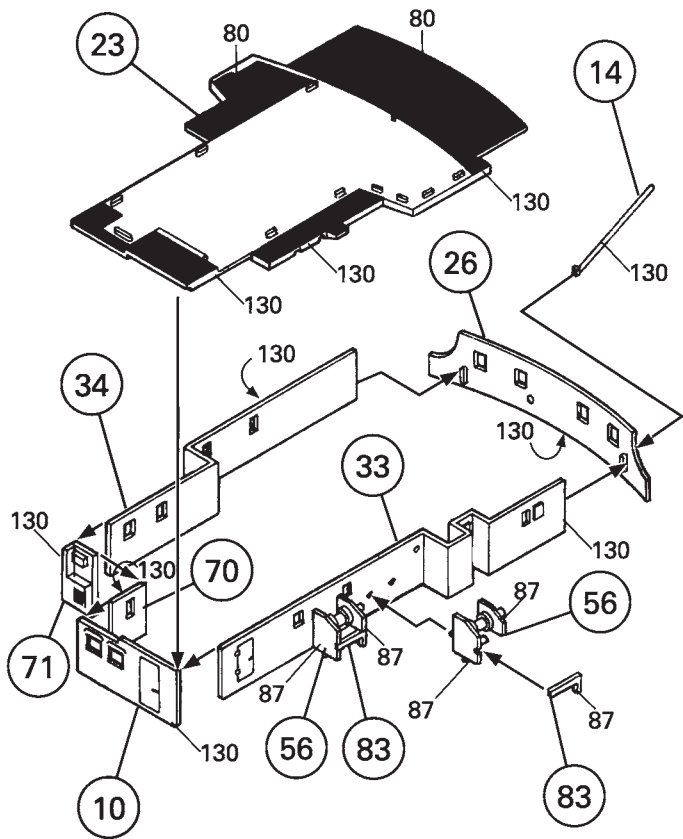

12

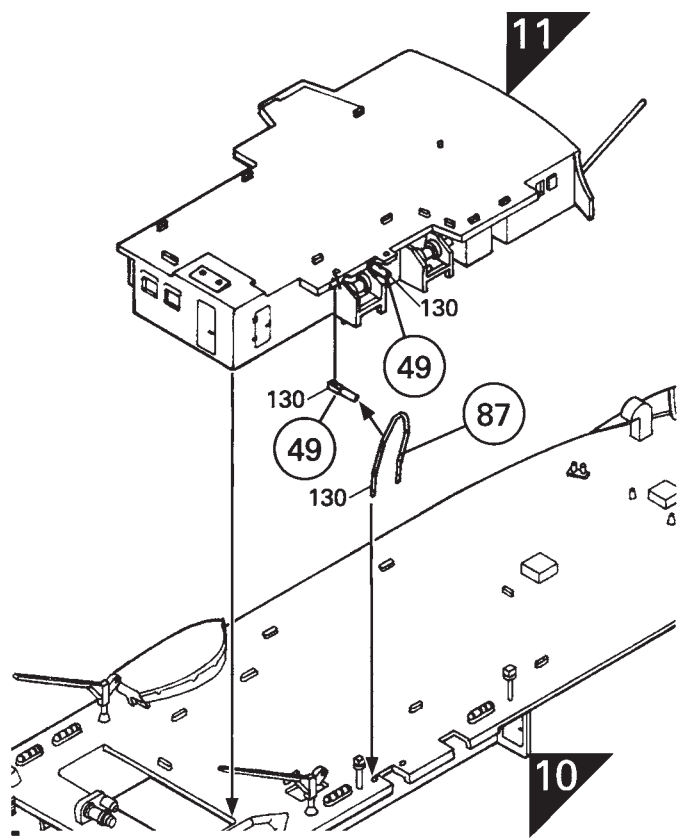

13

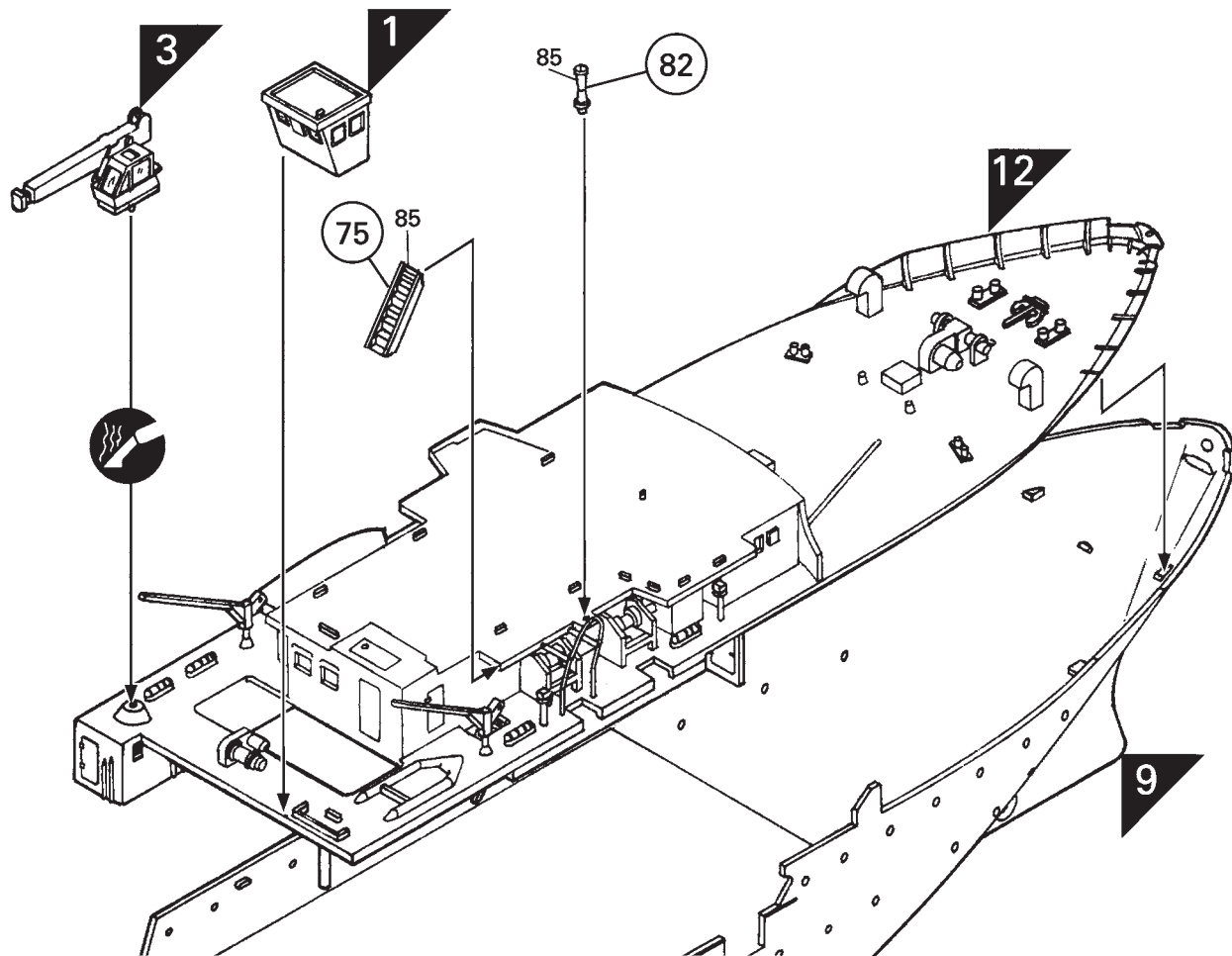

14

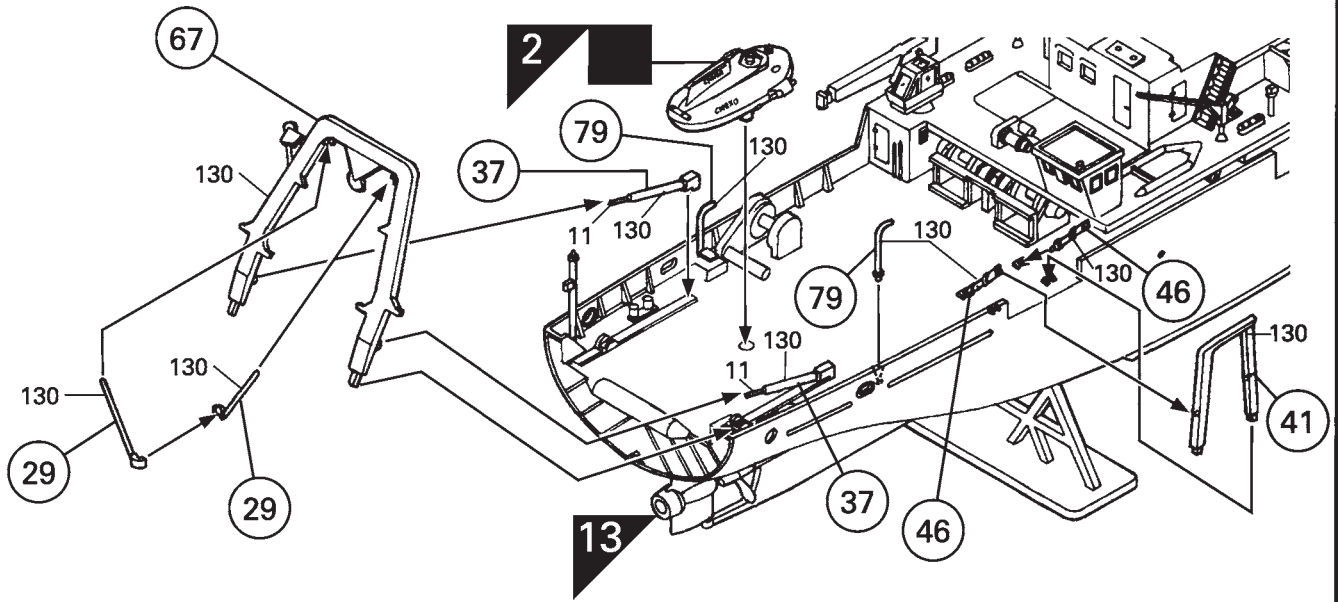



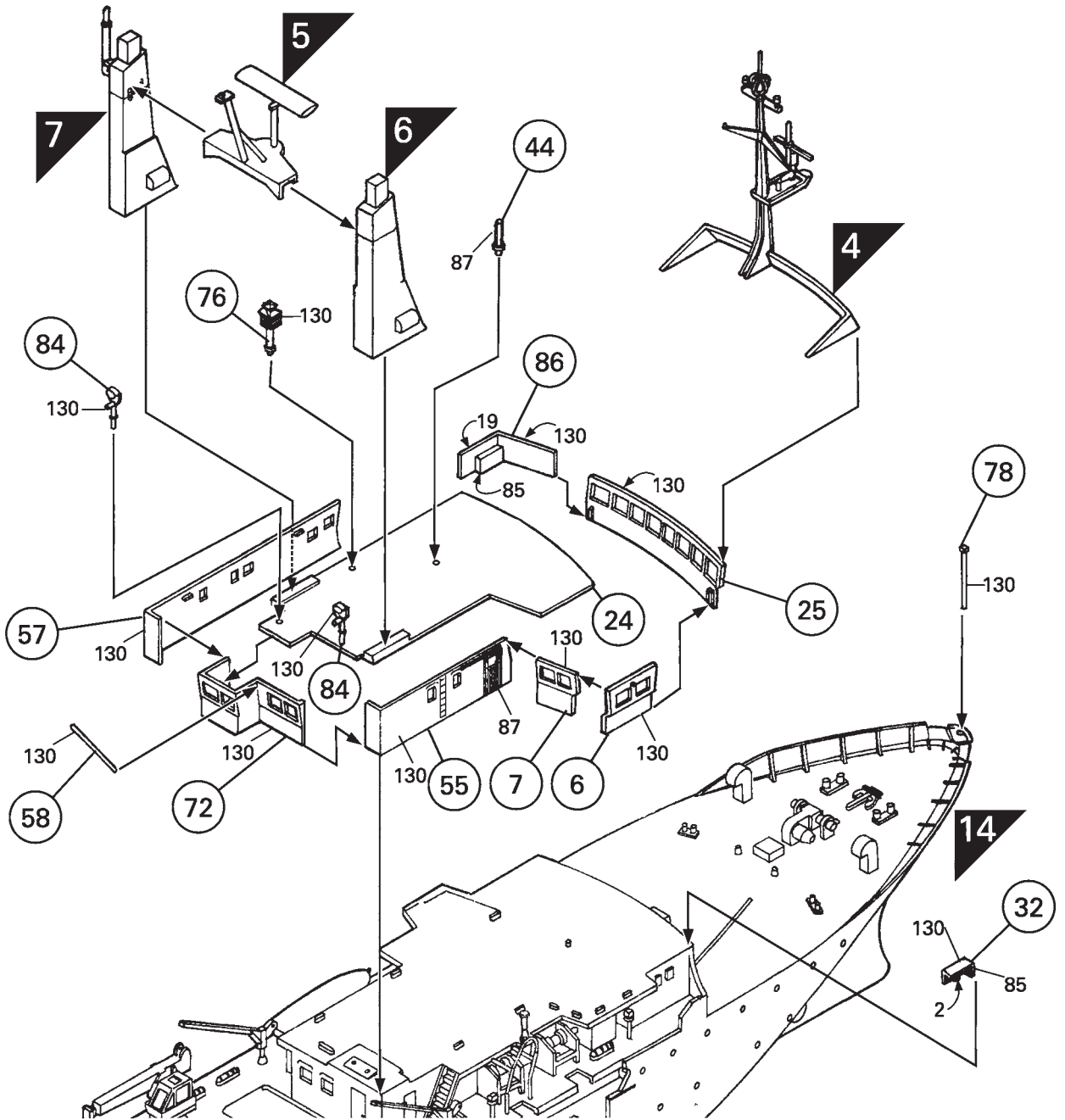

15

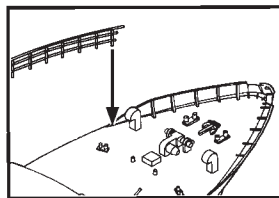
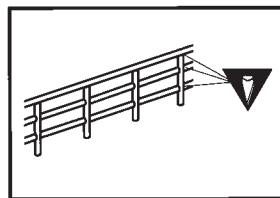
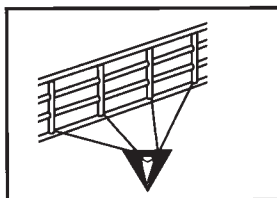
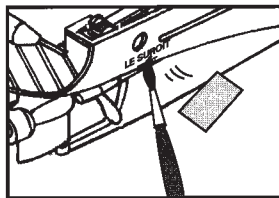
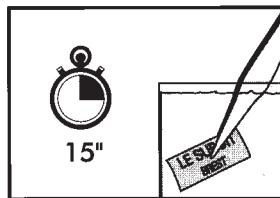
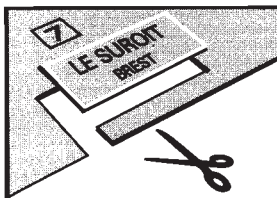
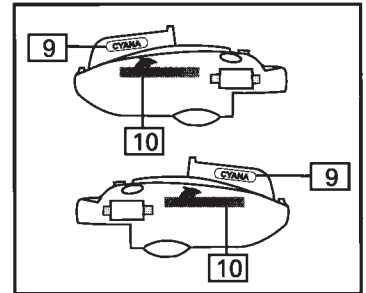
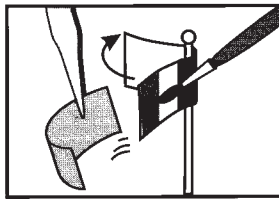
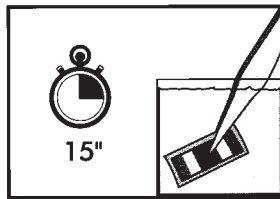
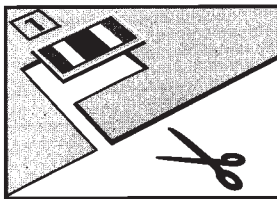
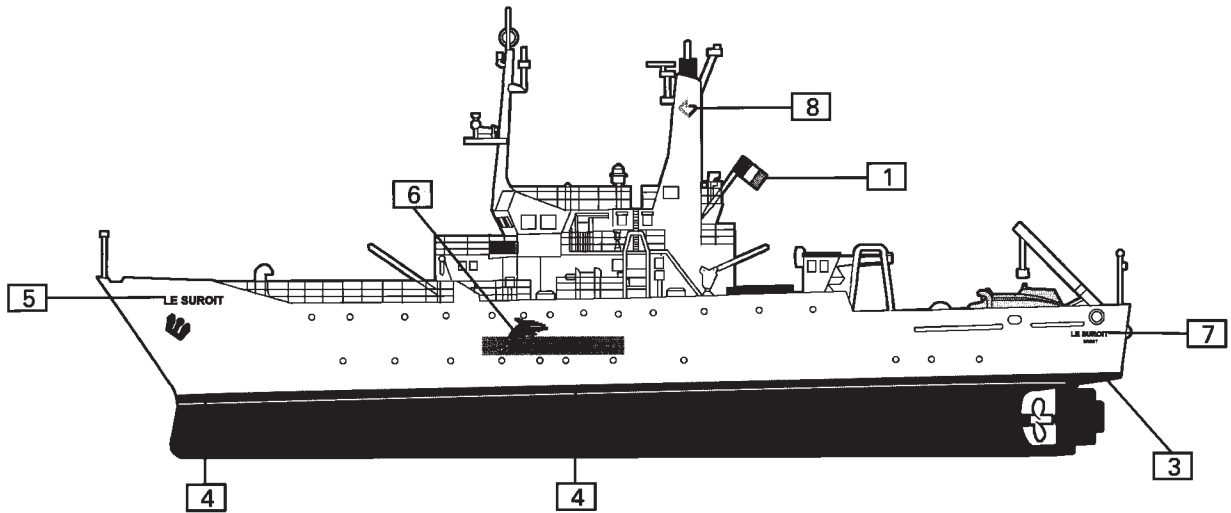
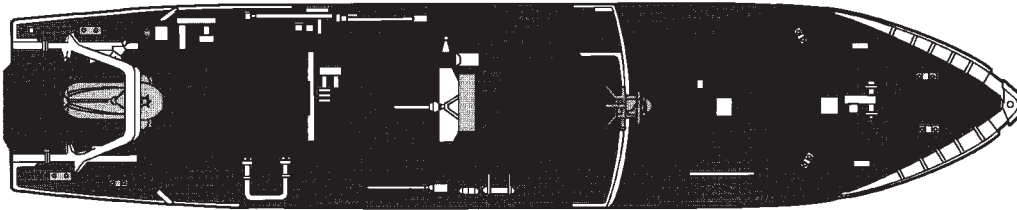
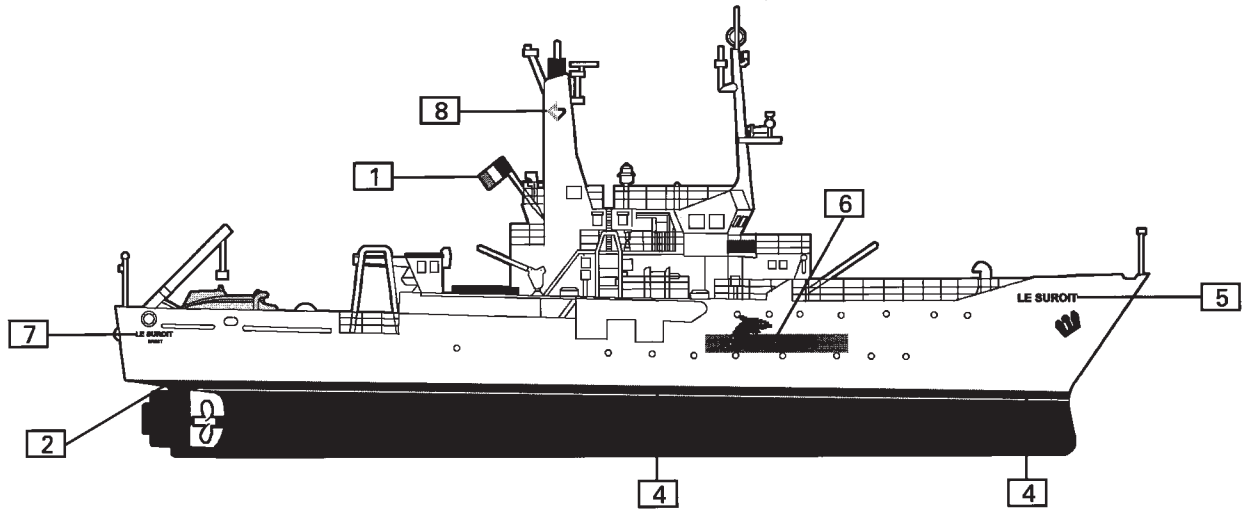

80615



-  73
-  80
-  85
-  130

SERVICE CONSOMMATEURS 

www.heller.fr

Pour toute demande de SAV, connectez-vous sur notre site
www.heller.fr puis envoyez votre demande détaillée via
l'onglet «NOUS CONTACTER».

For any request of SAV(after-sales service), please connect on
our website www.heller.fr then send us your detailed request
via the « NOUS CONTACTER» tab.

HELLER HOBBY GmbH
Erlenbacher Str. 3
42477 - Radevormwald
GERMANY



Fabriqué en France